

OUTDOOR UNIT SERVICE MANUAL



No. OBH865

Models

- MUZ-FT25VGHZ** - E1, ET1, SC1
- MUZ-FT35VGHZ** - E1, ET1, SC1
- MUZ-FT50VGHZ** - E1, ET1, SC1

Indoor unit service manual
MSZ-FT-VG Series (OBH864)

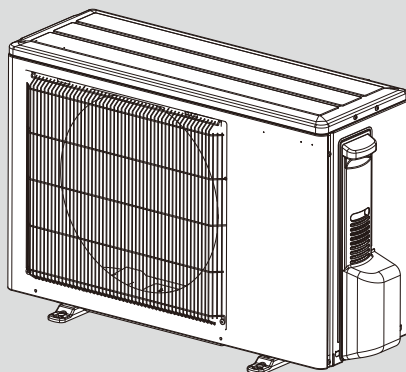

MUZ-FT25VGHZ

CONTENTS

| | |
|---|----|
| 1. TECHNICAL CHANGES..... | 2 |
| 2. SERVICING PRECAUTIONS FOR UNITS USING REFRIGERANT R32 | 3 |
| 3. PART NAMES AND FUNCTIONS | 5 |
| 4. SPECIFICATION | 6 |
| 5. NOISE CRITERIA CURVES | 8 |
| 6. OUTLINES AND DIMENSIONS..... | 9 |
| 7. WIRING DIAGRAM..... | 11 |
| 8. REFRIGERANT SYSTEM DIAGRAM | 13 |
| 9. PERFORMANCE CURVES | 15 |
| 10. ACTUATOR CONTROL | 27 |
| 11. SERVICE FUNCTIONS..... | 28 |
| 12. TROUBLESHOOTING..... | 29 |
| 13. DISASSEMBLY INSTRUCTIONS..... | 49 |

PARTS CATALOG (OBB865)

Use the specified refrigerant only

Never use any refrigerant other than that specified.

Doing so may cause a burst, an explosion, or fire when the unit is being used, serviced, or disposed of.

Correct refrigerant is specified in the manuals and on the spec labels provided with our products.

We will not be held responsible for mechanical failure, system malfunction, unit breakdown or accidents caused by failure to follow the instructions.

<Preparation before the repair service>

- Prepare the proper tools.
- Prepare the proper protectors.
- Provide adequate ventilation.
- After stopping the operation of the air conditioner, turn off the power-supply breaker and remove the power plug.
- Discharge the capacitor before the work involving the electric parts.

<Precautions during the repair service>

- Do not perform the work involving the electric parts with wet hands.
- Do not pour water into the electric parts.
- Do not touch the refrigerant.
- Do not touch the hot or cold areas in the refrigeration cycle.
- When the repair or the inspection of the circuit needs to be done without turning off the power, exercise great caution not to touch the live parts.

1

TECHNICAL CHANGES

MUZ-FT25VGHZ -**E1**, **ET1**, **SC1**

MUZ-FT35VGHZ -**E1**, **ET1**, **SC1**

MUZ-FT50VGHZ -**E1**, **ET1**, **SC1**

1. New model

Servicing precautions for units using refrigerant R32



This unit uses a flammable refrigerant.

If refrigerant leaks and comes in contact with fire or heating part, it will create harmful gas and there is risk of fire.

- Do not use means to accelerate the defrosting process or to clean, other than those recommended by the manufacturer.
- The appliance shall be stored in a room without continuously operating ignition sources (for example: open flames, an operating gas appliance or an operating electric heater.)
- Do not pierce or burn.
- Be aware that refrigerants may not contain an odor.
- Pipe-work shall be protected from physical damage.
- The installation of pipe-work shall be kept to a minimum.
- Compliance with national gas regulations shall be observed.
- Keep any required ventilation openings clear of obstruction.
- Servicing shall be performed only as recommended by the manufacturer.
- The appliance shall be stored so as to prevent mechanical damage from occurring.

Basic work procedures are the same as those for conventional units using refrigerant R410A. However, pay careful attention to the following points.

1. Information on servicing

① Checks on the Area

Prior to beginning work on systems containing flammable refrigerants, safety checks are necessary to ensure that the risk of ignition is minimized.

② Work Procedure

Work shall be undertaken under a controlled procedure so as to minimize the risk of a flammable gas or vapor being present while the work is being performed.

③ General Work Area

All maintenance staff and others working in the local area shall be instructed on the nature of work being carried out. Work in confined spaces shall be avoided. The area around the workspace shall be sectioned off. Ensure that the conditions within the area have been made safe by control of flammable material.

④ Checking for Presence of Refrigerant

The area shall be checked with an appropriate refrigerant detector prior to and during work, to ensure the technician is aware of potentially toxic or flammable atmospheres. Ensure that the leak detection equipment being used is suitable for use with all applicable refrigerants, i.e. non-sparking, adequately sealed or intrinsically safe.

⑤ Presence of Fire Extinguisher

If any hot work is to be conducted on the refrigeration equipment or any associated parts, appropriate fire extinguishing equipment shall be available to hand. Have a dry powder or CO2 fire extinguisher adjacent to the charging area.

⑥ No Ignition Sources

No person carrying out work in relation to a refrigeration system which involves exposing any pipe work shall use any sources of ignition in such a manner that it may lead to the risk of fire or explosion. All possible ignition sources, including cigarette smoking, should be kept sufficiently far away from the site of installation, repairing, removing and disposal, during which refrigerant can possibly be released to the surrounding space. Prior to work taking place, the area around the equipment is to be surveyed to make sure that there are no flammable hazards or ignition risks. "No Smoking" signs shall be displayed.

⑦ Ventilated Area

Ensure that the area is in the open or that it is adequately ventilated before breaking into the system or conducting any hot work. A degree of ventilation shall continue during the period that the work is carried out. The ventilation should safely disperse any released refrigerant and preferably expel it externally into the atmosphere.

⑧ Checks on the Refrigeration Equipment

Where electrical components are being changed, they shall be fit for the purpose and to the correct specification. At all times the manufacturer's maintenance and service guidelines shall be followed. If in doubt, consult the manufacturer's technical department for assistance.

The following checks shall be applied to installations using flammable refrigerants:

- The charge size is in accordance with the room size within which the refrigerant containing parts are installed.
- The ventilation machinery and outlets are operating adequately and are not obstructed.
- If an indirect refrigerating circuit is being used, the secondary circuit shall be checked for the presence of refrigerant.
- Marking to the equipment continues to be visible and legible. Markings and signs that are illegible shall be corrected.
- Refrigeration pipe or components are installed in a position where they are unlikely to be exposed to any substance which may corrode refrigerant containing components, unless the components are constructed of materials which are inherently resistant to being corroded or are suitably protected against being corroded.

⑨ Checks on Electrical Devices

Repair and maintenance to electrical components shall include initial safety checks and component inspection procedures. If a fault exists that could compromise safety, then no electrical supply shall be connected to the circuit until it is satisfactorily dealt with. If the fault cannot be corrected immediately but it is necessary to continue operation, an adequate temporary solution shall be used. This shall be reported to the owner of the equipment so all parties are advised.

Initial safety checks shall include that:

- capacitors are discharged: this shall be done in a safe manner to avoid possibility of sparking;
- no live electrical components and wiring are exposed while charging, recovering or purging the system;
- there is continuity of earth bonding

2. Repairs to Sealed Components

① During repairs to sealed components, all electrical supplies shall be disconnected from the equipment being worked upon prior to any removal of sealed covers, etc. If it is absolutely necessary to have an electrical supply to equipment during servicing, then a permanently operating form of leak detection shall be located at the most critical point to warn of a potentially hazardous situation.

② Particular attention shall be paid to the following to ensure that by working on electrical components, the casing is not altered in such a way that the level of protection is affected. This shall include damage to cables, excessive number of connections, terminals not made to original specification, damage to seals, incorrect fitting of glands, etc.

Ensure that the apparatus is mounted securely.

Ensure that seals or sealing materials have not degraded to the point that they no longer serve the purpose of preventing the ingress of flammable atmospheres. Replacement parts shall be in accordance with the manufacturer's specifications.

3. Repair to Intrinsic Safe Components

Do not apply any permanent inductive or capacitance loads to the circuit without ensuring that this will not exceed the permissible voltage and current permitted for the equipment in use.

Intrinsic safe components are the only types that can be worked on while live in the presence of a flammable atmosphere. The test apparatus shall be at the correct rating.

Replace components only with parts specified by the manufacturer. Other parts may result in the ignition of refrigerant in the atmosphere from a leak.

4. Cabling

Check that cabling will not be subject to wear, corrosion, excessive pressure, vibration, sharp edges or any other adverse environmental effects. The check shall also take into account the effects of aging or continual vibration from sources such as compressors or fans.

5. Detection of Flammable Refrigerants

Under no circumstances shall potential sources of ignition be used in the searching for or detection of refrigerant leaks. A halide torch (or any other detector using a naked flame) shall not be used.

6. Leak Detection Methods

Electronic leak detectors may be used to detect refrigerant leaks but, in the case of flammable refrigerants, the sensitivity may not be adequate, or may need recalibration. (Detection equipment shall be calibrated in a refrigerant-free area.) Ensure that the detector is not a potential source of ignition and is suitable for the refrigerant used. Leak detection equipment shall be set at a percentage of the LFL of the refrigerant and shall be calibrated to the refrigerant employed, and the appropriate percentage of gas (25 % maximum) is confirmed.

Leak detection fluids are suitable for use with most refrigerants but the use of detergents containing chlorine shall be avoided as the chlorine may react with the refrigerant and corrode the copper pipe-work.

If a leak is suspected, all naked flames shall be removed/extinguished.

If a leakage of refrigerant is found which requires brazing, all of the refrigerant shall be recovered from the system, or isolated (by means of shut off valves) in a part of the system remote from the leak. For appliances containing flammable refrigerants, oxygen free nitrogen (OFN) shall then be purged through the system both before and during the brazing process.

7. Removal and Evacuation

When breaking into the refrigerant circuit to make repairs - or for any other purpose conventional procedures shall be used. However, for flammable refrigerants it is important that best practice is followed since flammability is a consideration. The following procedure shall be adhered to:

- remove refrigerant
- purge the circuit with inert gas
- evacuate
- purge again with inert gas
- open the circuit by cutting or brazing.

The refrigerant charge shall be recovered into the correct recovery cylinders. For appliances containing flammable refrigerants, the system shall be "flushed" with OFN to render the unit safe. This process may need to be repeated several times. Compressed air or oxygen shall not be used for purging refrigerant systems.

For appliances containing flammable refrigerants, flushing shall be achieved by breaking the vacuum in the system with OFN and continuing to fill until the working pressure is achieved, then venting to atmosphere, and finally pulling down to a vacuum. This process shall be repeated until no refrigerant is within the system. When the final OFN charge is used, the system shall be vented down to atmospheric pressure to enable work to take place. This operation is absolutely vital if brazing operations on the pipe-work are to take place.

Ensure that the outlet for the vacuum pump is not close to any ignition sources and that ventilation is available.

8. Charging Procedures

In addition to conventional charging procedures, the following requirements shall be followed:

- Ensure that contamination of different refrigerants does not occur when using charging equipment. Hoses or lines shall be as short as possible to minimize the amount of refrigerant contained in them.
- Cylinders shall be kept upright.
- Ensure that the refrigeration system is earthed prior to charging the system with refrigerant.
- Label the system when charging is complete (if not already).
- Extreme care shall be taken not to overfill the refrigeration system.

Prior to recharging the system, it shall be pressure-tested with the appropriate purging gas. The system shall be leak-tested on completion of charging but prior to commissioning. A follow up leak test shall be carried out prior to leaving the site.

9. Decommissioning

Before carrying out this procedure, it is essential that the technician is completely familiar with the equipment and all its detail. It is recommended good practice that all refrigerants are recovered safely. Prior to the task being carried out, an oil and refrigerant sample shall be taken in case analysis is required prior to reuse of reclaimed refrigerant. It is essential that electrical power is available before the task is commenced.

- a) Become familiar with the equipment and its operation.
- b) Isolate system electrically.
- c) Before attempting the procedure, ensure that:
 - mechanical handling equipment is available, if required, for handling refrigerant cylinders;
 - all personal protective equipment is available and being used correctly;
 - the recovery process is supervised at all times by a competent person;
 - recovery equipment and cylinders conform to the appropriate standards.
- d) Pump down refrigerant system, if possible.
- e) If a vacuum is not possible, make a manifold so that refrigerant can be removed from various parts of the system.
- f) Make sure that cylinder is situated on the scales before recovery takes place.
- g) Start the recovery machine and operate in accordance with manufacturer's instructions.
- h) Do not overfill cylinders. (no more than 80 % volume liquid charge).
- i) Do not exceed the maximum working pressure of the cylinder, even temporarily.
- j) When the cylinders have been filled correctly and the process completed, make sure that the cylinders and the equipment are removed from site promptly and all isolation valves on the equipment are closed off.
- k) Recovered refrigerant shall not be charged into another refrigeration system unless it has been cleaned and checked.

10. Labeling

Equipment shall be labeled stating that it has been de-commissioned and emptied of refrigerant. The label shall be dated and signed. For appliances containing flammable refrigerants, ensure that there are labels on the equipment stating the equipment contains flammable refrigerant.

11. Recovery

When removing refrigerant from a system, either for servicing or decommissioning, it is recommended good practice that all refrigerants are removed safely.

When transferring refrigerant into cylinders, ensure that only appropriate refrigerant recovery cylinders are employed. Ensure that the correct number of cylinders for holding the total system charge are available. All cylinders to be used are designated for the recovered refrigerant and labeled for that refrigerant (i.e. special cylinders for the recovery of refrigerant). Cylinders shall be complete with pressure-relief valve and associated shut-off valves in good working order.

Empty recovery cylinders are evacuated and, if possible, cooled before recovery occurs.

The recovery equipment shall be in good working order with a set of instructions concerning the equipment that is at hand and shall be suitable for the recovery of all appropriate refrigerants including, when applicable, flammable refrigerants. In addition, a set of calibrated weighing scales shall be available and in good working order. Hoses shall be complete with leak-free disconnect couplings and in good condition. Before using the recovery machine, check that it is in satisfactory working order, has been properly maintained and that any associated electrical components are sealed to prevent ignition in the event of a refrigerant release. Consult manufacturer if in doubt.

The recovered refrigerant shall be returned to the refrigerant supplier in the correct recovery cylinder, and the relevant waste transfer note arranged. Do not mix refrigerants in recovery units and especially not in cylinders.

If compressors or compressor oils are to be removed, ensure that they have been evacuated to an acceptable level to make certain that flammable refrigerant does not remain within the lubricant. The evacuation process shall be carried out prior to returning the compressor to the suppliers. Only electric heating to the compressor body shall be employed to accelerate this process. When oil is drained from a system, it shall be carried out safely.

MUZ-FT25VGHZ

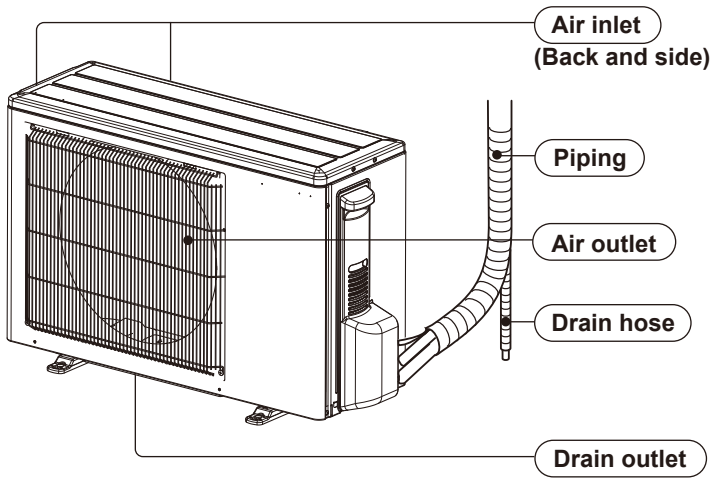

MUZ-FT35VGHZ MUZ-FT50VGHZ

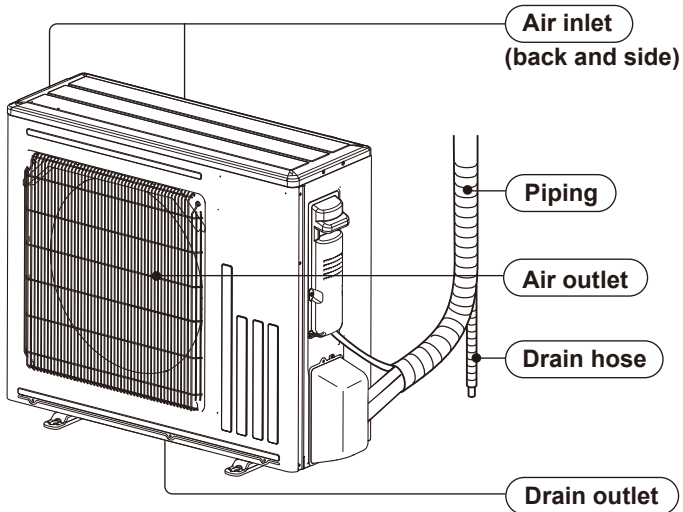

4

SPECIFICATION

| Outdoor model | | | | MUZ-FT25VGHZ | MUZ-FT35VGHZ | MUZ-FT50VGHZ | | |
|---|---------------------------|---------|---------|----------------------------|-----------------|-----------------|-------|-------|
| Power supply | | | | Single phase, 230 V, 50 Hz | | | | |
| Capacity Rated (Min.-Max.) | Cooling | kW | | 2.5 (0.8 - 3.5) | 3.5 (0.8 - 4.0) | 5.0 (0.8 - 5.2) | | |
| | Heating | | | 3.2 (0.9 - 6.2) | 4.0 (0.9 - 6.6) | 5.0 (0.9 - 7.8) | | |
| Breaker Capacity | | | A | 12 | 16 | 16 | | |
| Electrical data | Power input *1 (Set) | Cooling | W | 580 | 910 | 1,630 | | |
| | | Heating | | 760 | 1,020 | 1,300 | | |
| | Running current *1 (Set) | Cooling | A | | 2.8 | 4.1 | 7.3 | |
| | | Heating | | | 3.6 | 4.6 | 5.8 | |
| | Power factor *1 (Set) | Cooling | % | | 90 | 96 | 97 | |
| | | Heating | | | 91 | 96 | 97 | |
| Starting current *1 (Set) | | | A | 3.6 | 4.6 | 7.3 | | |
| Coefficient of performance (COP) *1 (Set) | | Cooling | | 4.31 | 3.85 | 3.07 | | |
| | | Heating | | 4.21 | 3.92 | 3.85 | | |
| Compressor | Model | | | SVB130FBBMT | SVB130FBBMT | SVB130FBBMT | | |
| | Output | | W | 900 | 900 | 900 | | |
| | Current *1 | Cooling | A | | 2.32 | 3.51 | 6.67 | |
| | | Heating | | | 3.02 | 3.94 | 5.09 | |
| | Refrigeration oil (Model) | | L | 0.35 (FW68S) | 0.35 (FW68S) | 0.35 (FW68S) | | |
| Fan motor | Model | | | RC0J50-NC | RC0J50-RA | RC0J50-RA | | |
| | Current *1 | Cooling | A | | 0.22 | 0.3 | | |
| | | Heating | | | 0.23 | 0.3 | | |
| Dimensions W × H × D | | | mm | 800 × 550 × 285 | 800 × 714 × 285 | 800 × 714 × 285 | | |
| Weight | | | kg | 34 | 40 | 40 | | |
| Special remarks | Dehumidification | | Cooling | L/h | 0.2 | 1.0 | 2.3 | |
| | Airflow *1 | Cooling | High | m ³ /h | | 2,058 | 2,664 | 2,664 |
| | | | Low | | | 906 | 1,320 | 1,320 |
| | | Heating | High | | | 1,962 | 2,412 | 2,412 |
| | | | Med. | | | 1,686 | 2,412 | 2,412 |
| | | | Low | | | 1,356 | 1,290 | 1,320 |
| | Sound level *1 | Cooling | | dB(A) | | 46 | 49 | 51 |
| | | Heating | | | | 49 | 50 | 54 |
| | Fan speed | Cooling | High | rpm | | 940 | 940 | 940 |
| | | | Low | | | 460 | 490 | 490 |
| | | Heating | High | | | 900 | 840 | 840 |
| | | | Med. | | | 780 | 840 | 840 |
| | | | Low | | | 640 | 480 | 490 |
| | Fan speed regulator | | | | | 3 | 3 | 3 |
| Refrigerant filling capacity (R32) | | | kg | 0.85 | 0.95 | 0.95 | | |

NOTE: Test conditions are based on ISO 5151.

Cooling: Indoor Dry-bulb temperature 27°C Wet-bulb temperature 19°C
 Outdoor Dry-bulb temperature 35°C Wet-bulb temperature 24°C
 Heating: Indoor Dry-bulb temperature 20°C
 Outdoor Dry-bulb temperature 7°C Wet-bulb temperature 6°C

*1 Measured under rated operating frequency.

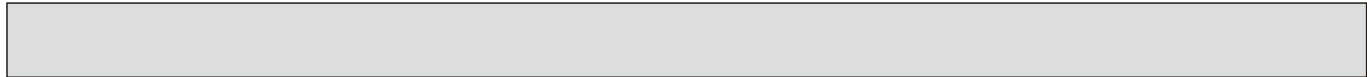

Specifications and rated conditions of main electric parts

| Item | Model | MUZ-FT25VGHZ | MUZ-FT35VGHZ | MUZ-FT50VGHZ |
|----------------------------|--------------------|--------------------------------|--------------|--------------|
| Smoothing capacitor | (C61, C62, C63) | 600 μ F/ 620 μ F 420 V | | |
| Diode module | (DB61) | 15 A 600 V | 25A 600 V | |
| | (DB65) | 25A 600V | | |
| Fuse | (F701, F801, F901) | T3.15AL250V | | |
| Defrost heater | (H) | 230 V 60 W | | |
| Power module | (IC700) | 20A 600 V | | |
| | (IC932) | 5 A 600 V | | |
| Expansion valve coil | (LEV) | 12 V DC | | |
| Reactor | (L61) | 23 mH | | |
| Switching power transistor | (Q821) | 30A/37A 600V | | |
| Circuit protection | (PTC64, PTC65) | 33 Ω | | |
| Terminal block | (TB1) | 5 P | | |
| Relay | (X63) | 3 A 250 V | | |
| | (X64) | 20 A 250 V | | |
| | (X66) | 3 A 250 V | | |
| | (X69) | 10 A 230 V | | |
| R.V. coil | (21S4) | 220-240 V AC | | |
| Heater protector | (26H) | Open 45°C | | |

MUZ-FT25VGHZ

| FUNCTION | SPL(dB(A)) | LINE |
|----------|------------|------|
| COOLING | 46 | ●—● |
| HEATING | 49 | □—□ |

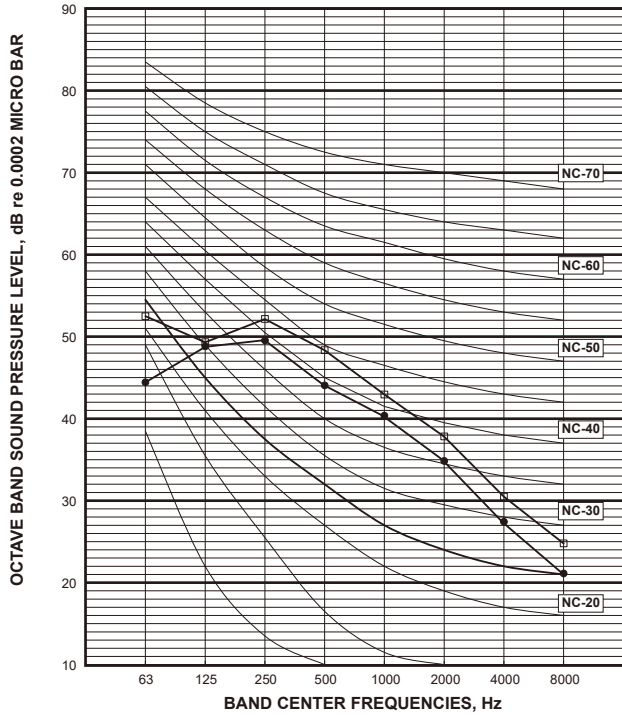

MUZ-FT35VGHZ

| FUNCTION | SPL(dB(A)) | LINE |
|----------|------------|------|
| COOLING | 49 | ●—● |
| HEATING | 50 | □—□ |

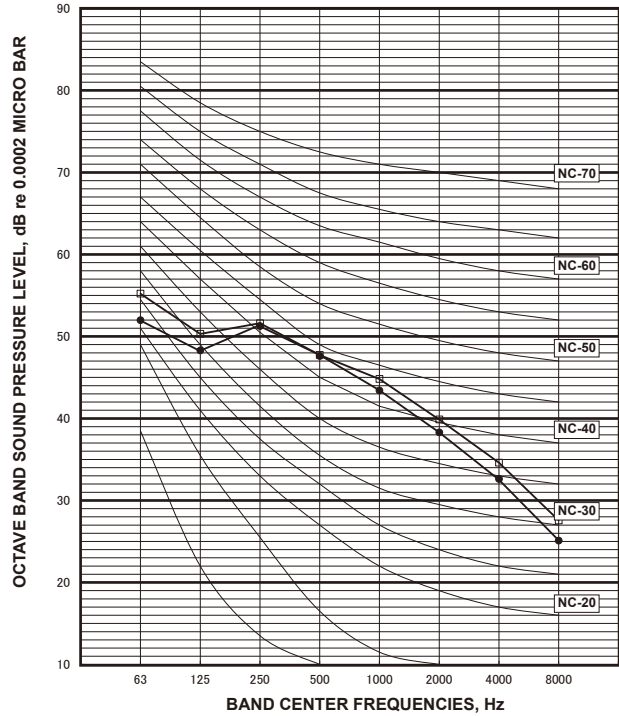

MUZ-FT50VGHZ

| FUNCTION | SPL(dB(A)) | LINE |
|----------|------------|------|
| COOLING | 51 | ●—● |
| HEATING | 54 | □—□ |

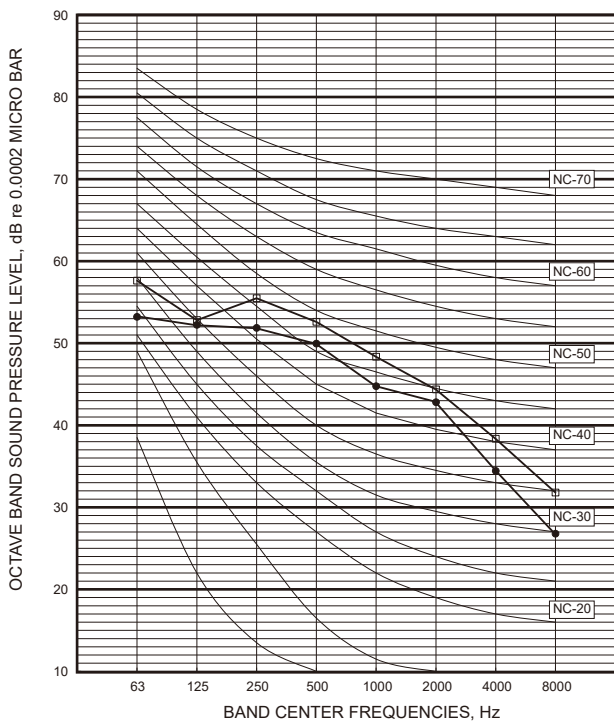

Test conditions

Cooling: Dry-bulb temperature 35°C

Heating: Dry-bulb temperature 7°C Wet-bulb temperature 6°C

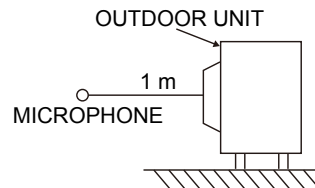

6

OUTLINES AND DIMENSIONS

MUZ-FT25VGHZ

Unit: mm

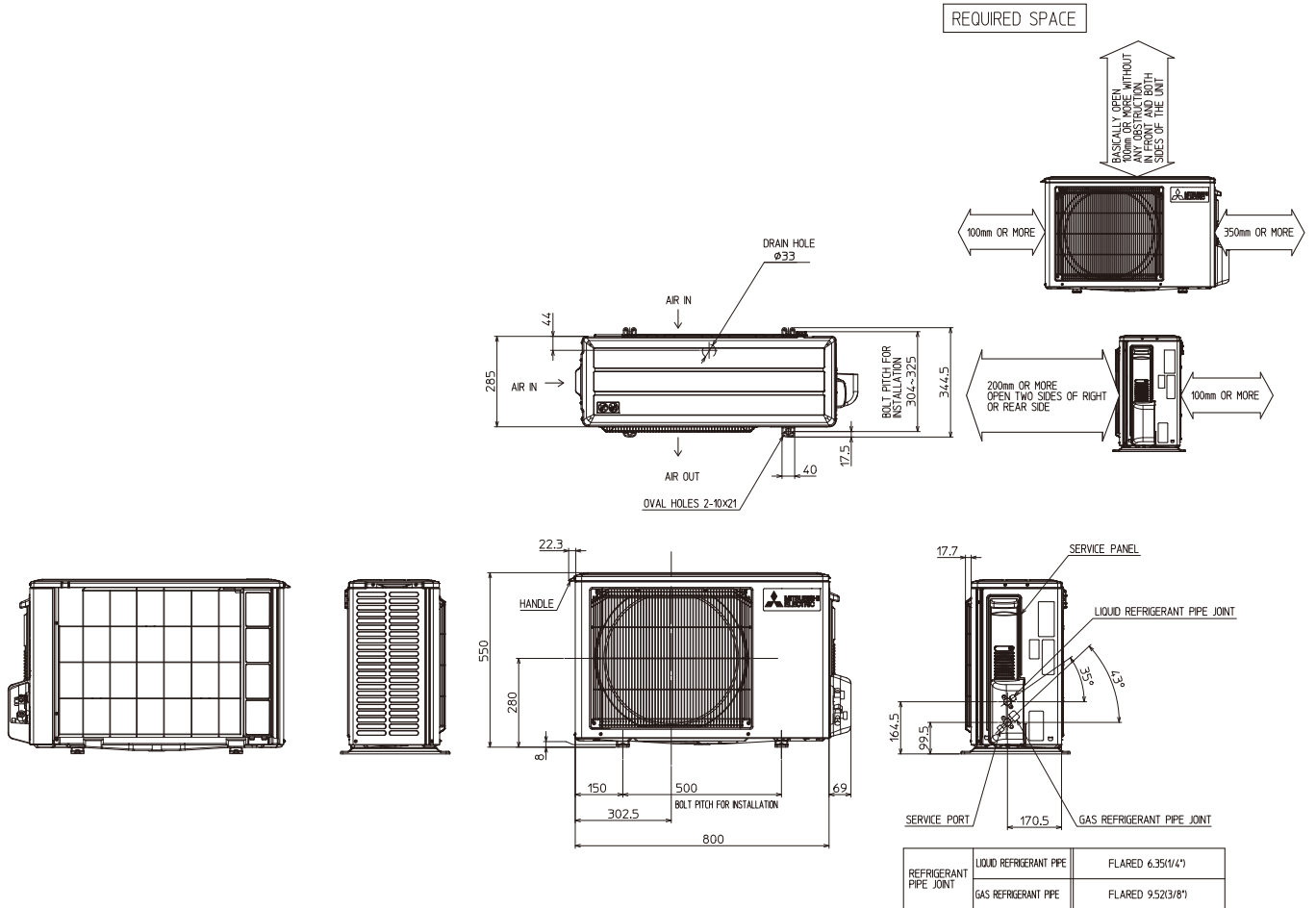

MUZ-FT35VGHZ MUZ-FT50VGHZ

Unit: mm

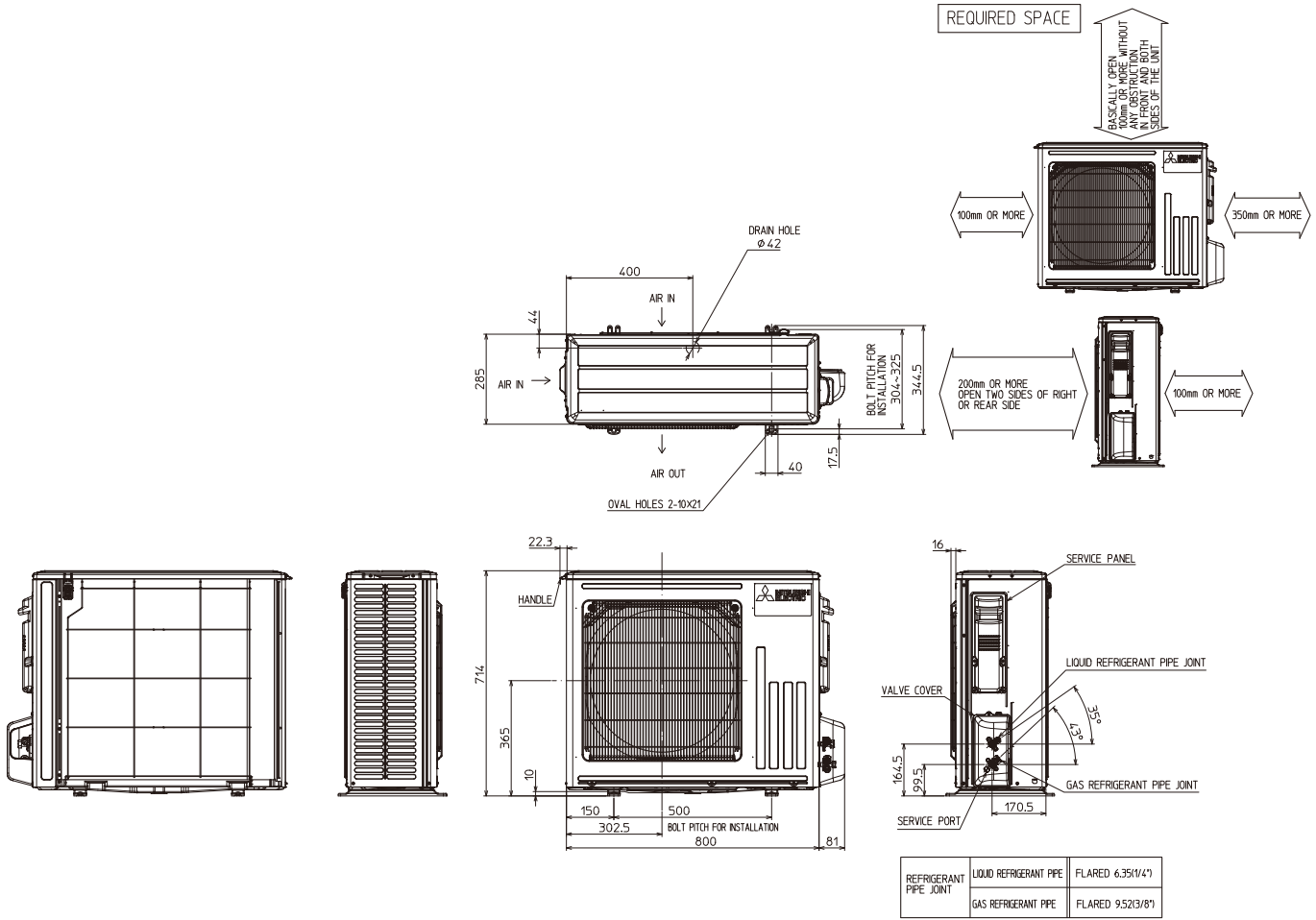

7

WIRING DIAGRAM

MUZ-FT25VGHZ -[E1], [SC1] MUZ-FT35VGHZ -[E1], [SC1]

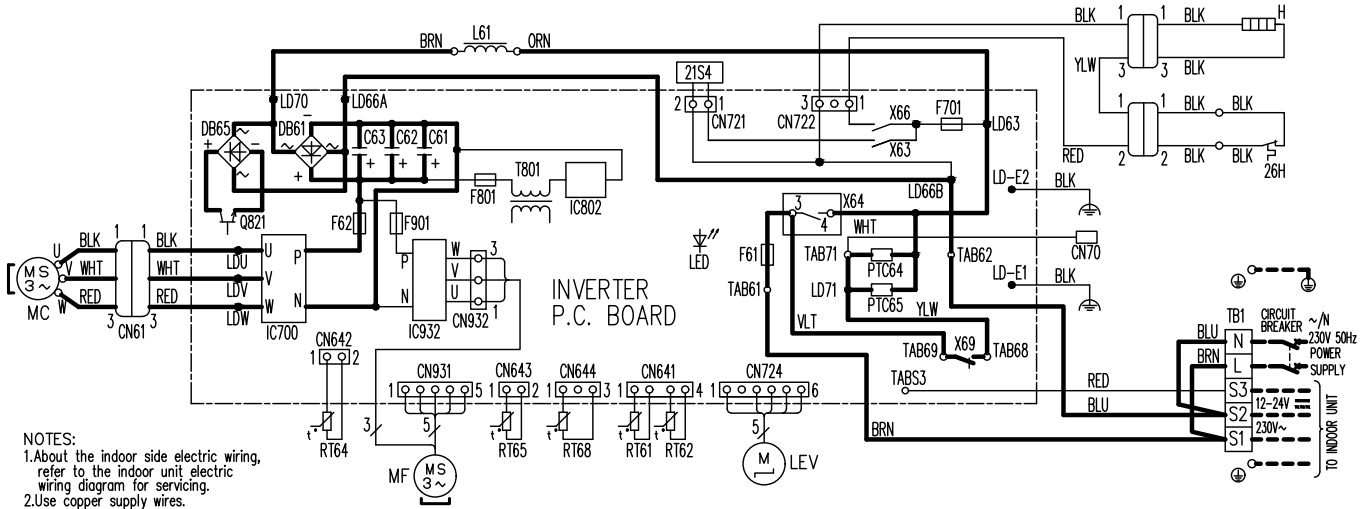

- NOTES:
- About the indoor side electric wiring, refer to the indoor unit electric wiring diagram for servicing.
 - Use copper supply wires.
 - Symbols indicate, : Terminal block
 : Connector

| SYMBOL | NAME | SYMBOL | NAME | SYMBOL | NAME |
|------------------|---------------------|--------------|----------------------------|--------------------|---|
| CN61 | CONNECTOR | LED | LED | RT64 | FIN TEMP. THERMISTOR |
| C61, C62, C63 | SMOOTHING CAPACITOR | LEV | EXPANSION VALVE COIL | RT65 | AMBIENT TEMP. THERMISTOR |
| DB61, DB65 | DIODE MODULE | L61 | REACTOR | RT68 | OUTDOOR HEAT EXCHANGER TEMP. THERMISTOR |
| F61 | FUSE (25A 250V) | MC | COMPRESSOR | TB1 | TERMINAL BLOCK |
| F62 | FUSE (15A 250V) | MF | FAN MOTOR | T801 | TRANSFORMER |
| F701, F801, F901 | FUSE (T3.15A/250V) | PTC64, PTC65 | CIRCUIT PROTECTION | X63, X64, X66, X69 | RELAY |
| H | DEFROST HEATER | Q821 | SWITCHING POWER TRANSISTOR | 21S4 | REVERSING VALVE COIL |
| IC700, IC932 | POWER MODULE | RT61 | DEFROST THERMISTOR | 26H | HEATER PROTECTOR |
| IC802 | POWER DEVICE | RT62 | DISCHARGE TEMP. THERMISTOR | | |

MUZ-FT50VGHZ -[E1], [SC1]

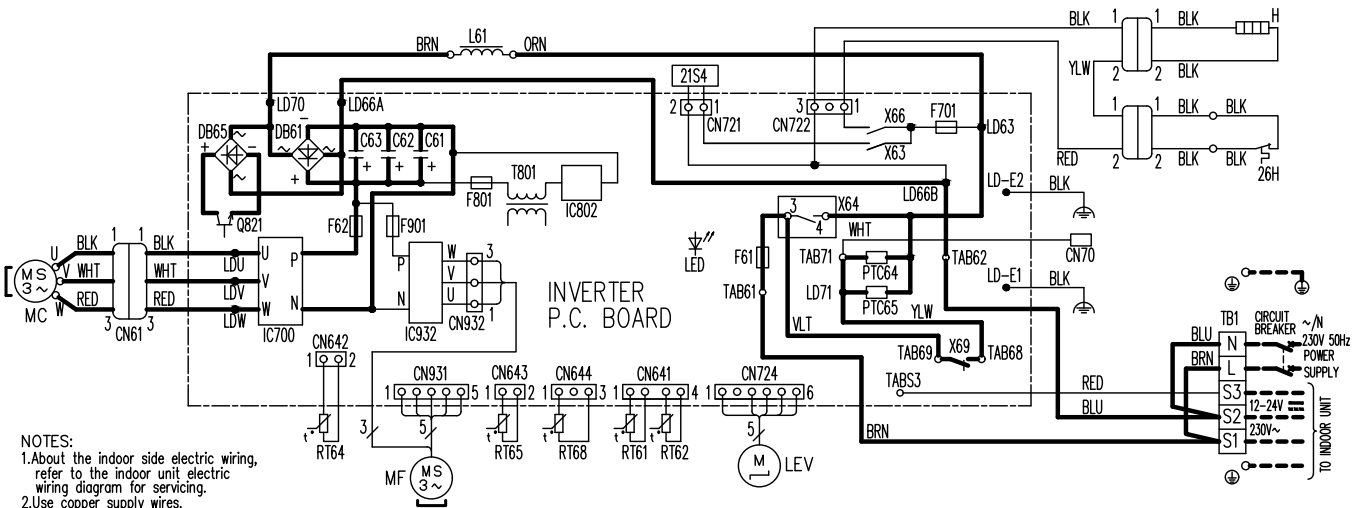

- NOTES:
- About the indoor side electric wiring, refer to the indoor unit electric wiring diagram for servicing.
 - Use copper supply wires.
 - Symbols indicate, : Terminal block
 : Connector

| SYMBOL | NAME | SYMBOL | NAME | SYMBOL | NAME |
|------------------|---------------------|--------------|----------------------------|--------------------|---|
| CN61 | CONNECTOR | LED | LED | RT64 | FIN TEMP. THERMISTOR |
| C61, C62, C63 | SMOOTHING CAPACITOR | LEV | EXPANSION VALVE COIL | RT65 | AMBIENT TEMP. THERMISTOR |
| DB61, DB65 | DIODE MODULE | L61 | REACTOR | RT68 | OUTDOOR HEAT EXCHANGER TEMP. THERMISTOR |
| F61 | FUSE (25A 250V) | MC | COMPRESSOR | TB1 | TERMINAL BLOCK |
| F62 | FUSE (15A 250V) | MF | FAN MOTOR | T801 | TRANSFORMER |
| F701, F801, F901 | FUSE (T3.15A/250V) | PTC64, PTC65 | CIRCUIT PROTECTION | X63, X64, X66, X69 | RELAY |
| H | DEFROST HEATER | Q821 | SWITCHING POWER TRANSISTOR | 21S4 | REVERSING VALVE COIL |
| IC700, IC932 | POWER MODULE | RT61 | DEFROST THERMISTOR | 26H | HEATER PROTECTOR |
| IC802 | POWER DEVICE | RT62 | DISCHARGE TEMP. THERMISTOR | | |

MUZ-FT25VGHZ - ET1 MUZ-FT35VGHZ - ET1

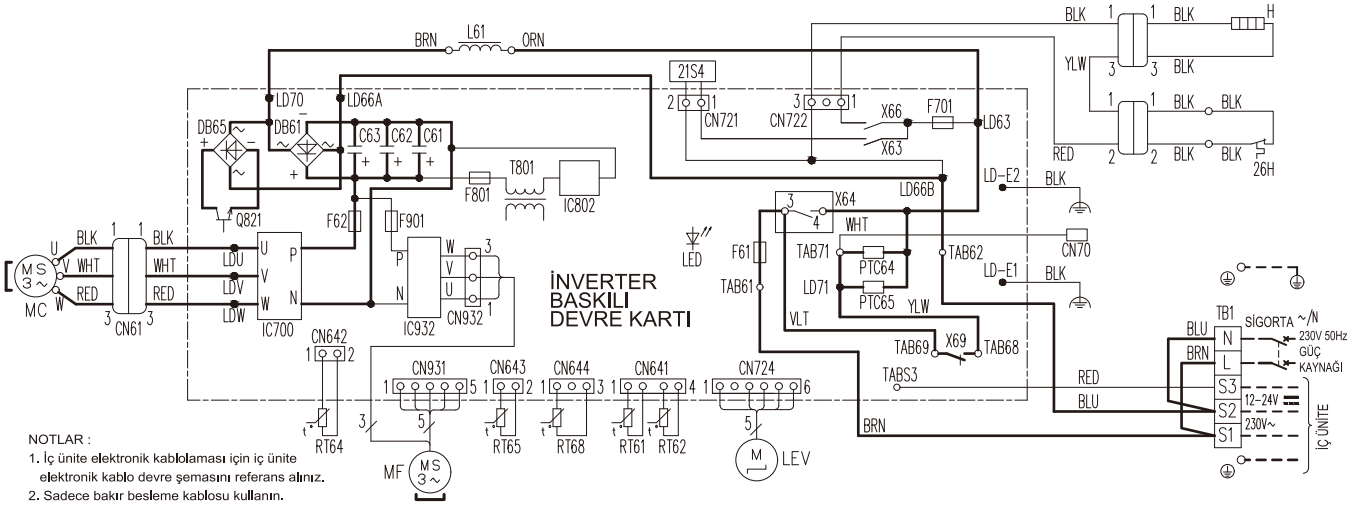

| SEMBOL | PARÇA ADI | SEMBOL | PARÇA ADI | SEMBOL | PARÇA ADI |
|----------------|------------------------|-------------|---------------------------|-----------------|---------------------------------------|
| CN61 | KONNEKTÖR | LED | LED | RT64 | FIN SICAKLIK TERMİSTÖRÜ |
| C61,C62,C63 | KAPASİTÖR | LEV | GENLEŞME VANASI SARGISI | RT65 | ORTAM SICAKLIK TERMİSTÖRÜ |
| DB61,DB65 | DIYOT MODÜLÜ | L61 | REAKTÖR | RT68 | DIŞ ÜNİTE EŞANJÖR SICAKLIK TERMİSTÖRÜ |
| F61 | SİGORTA (25A 250V) | MC | KOMPRESÖR | TB1 | TERMINAL BLOĞU |
| F62 | SİGORTA (15A 250V) | MF | FAN MOTORU | T801 | TRANSFORMATÖR |
| F701,F801,F901 | SİGORTA (T3. 15AL250V) | PTC64,PTC65 | DEVRE KORUMASI | T801 | TRANSFORMATÖR |
| H | Buz Çözme Isıtıcısı | Q821 | SIVIÇLI GÜÇ TRANSİSTÖRÜ | X63,X64,X66,X69 | RÖLE |
| IC700,IC932 | GÜÇ MODÜLÜ | RT61 | DEFROST TERMİSTÖRÜ | 21S4 | 4 YOLLU VANA SARGISI |
| IC802 | GÜÇ CİHAZI | RT62 | BASMA SICAKLIK TERMİSTÖRÜ | 26H | Isıtıcı Koruyucu |

MUZ-FT50VGHZ - ET1

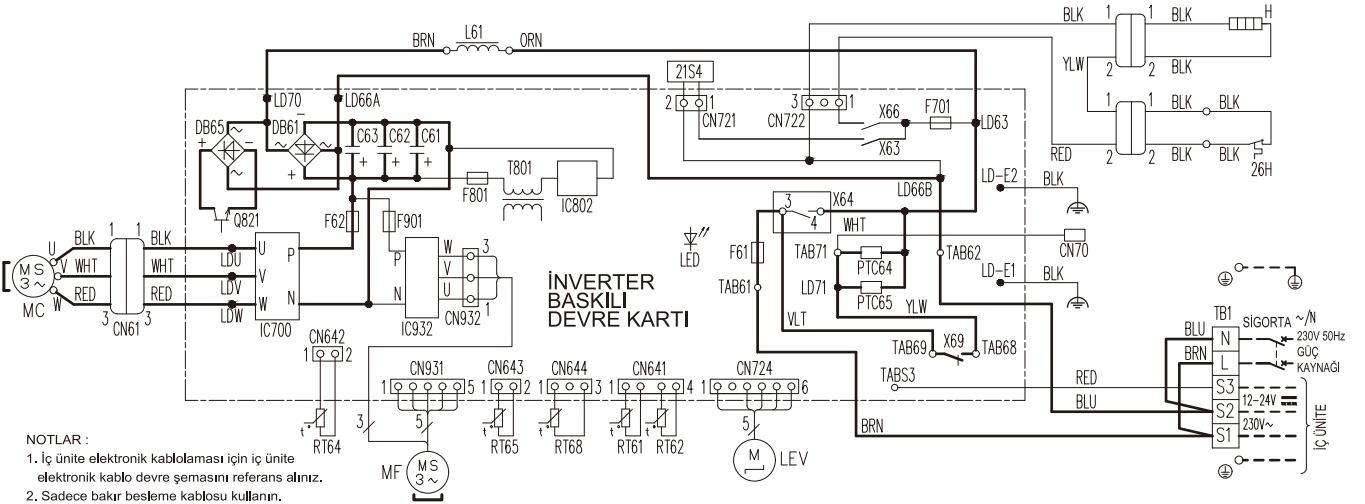

| SEMBOL | PARÇA ADI | SEMBOL | PARÇA ADI | SEMBOL | PARÇA ADI |
|----------------|------------------------|-------------|---------------------------|-----------------|---------------------------------------|
| CN61 | KONNEKTÖR | LED | LED | RT64 | FIN SICAKLIK TERMİSTÖRÜ |
| C61,C62,C63 | KAPASİTÖR | LEV | GENLEŞME VANASI SARGISI | RT65 | ORTAM SICAKLIK TERMİSTÖRÜ |
| DB61,DB65 | DIYOT MODÜLÜ | L61 | REAKTÖR | RT68 | DIŞ ÜNİTE EŞANJÖR SICAKLIK TERMİSTÖRÜ |
| F61 | SİGORTA (25A 250V) | MC | KOMPRESÖR | TB1 | TERMINAL BLOĞU |
| F62 | SİGORTA (15A 250V) | MF | FAN MOTORU | T801 | TRANSFORMATÖR |
| F701,F801,F901 | SİGORTA (T3. 15AL250V) | PTC64,PTC65 | DEVRE KORUMASI | T801 | TRANSFORMATÖR |
| H | Buz Çözme Isıtıcısı | Q821 | SIVIÇLI GÜÇ TRANSİSTÖRÜ | X63,X64,X66,X69 | RÖLE |
| IC700,IC932 | GÜÇ MODÜLÜ | RT61 | DEFROST TERMİSTÖRÜ | 21S4 | 4 YOLLU VANA SARGISI |
| IC802 | GÜÇ CİHAZI | RT62 | BASMA SICAKLIK TERMİSTÖRÜ | 26H | Isıtıcı Koruyucu |

MUZ-FT25VGHZ

Unit: mm

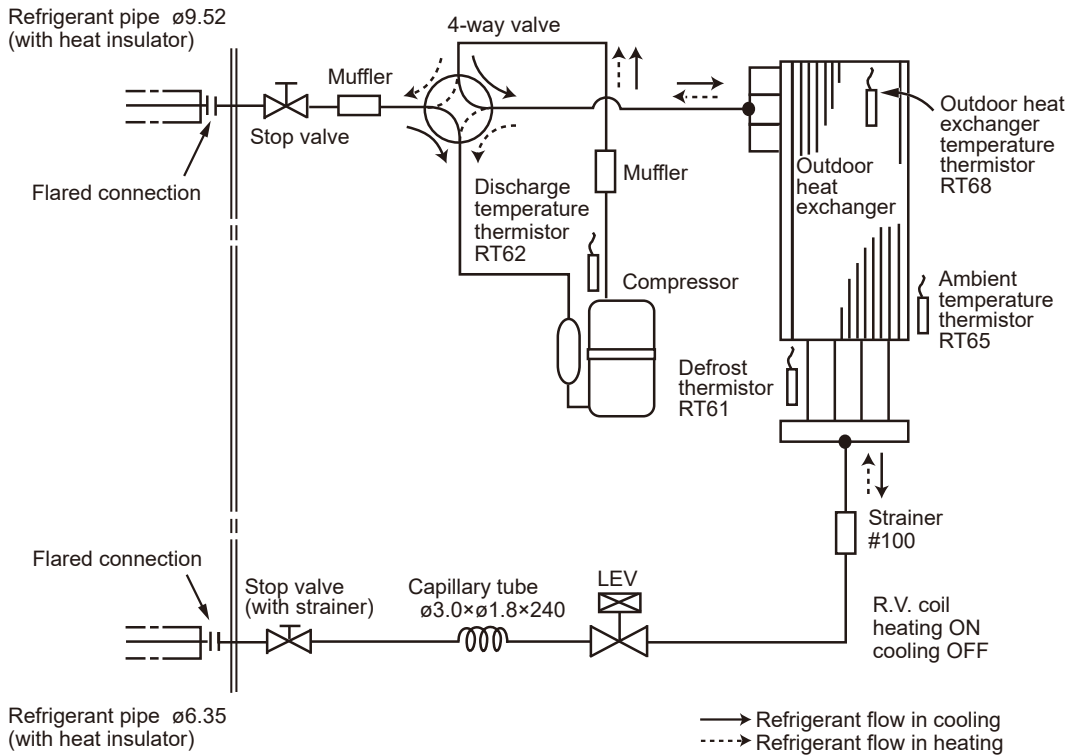

MUZ-FT35VGHZ MUZ-FT50VGHZ

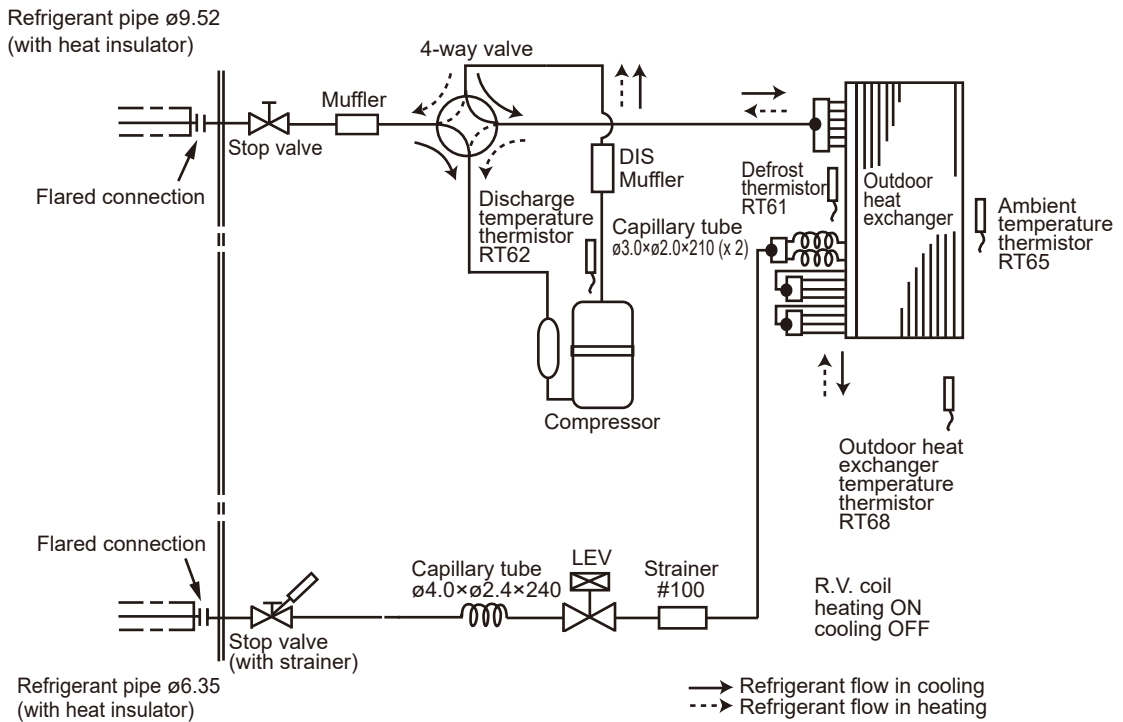

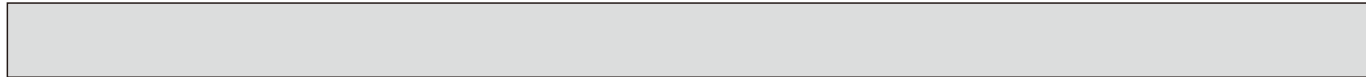

MAX. REFRIGERANT PIPING LENGTH and MAX. HEIGHT DIFFERENCE

| Model | Refrigerant piping: m | | Piping size O.D: mm | |
|--------------|-----------------------|--------------------------|---------------------|--------|
| | Max. Length A | Max. Height difference B | Gas | Liquid |
| MUZ-FT25VGHZ | 20 | 12 | 9.52 | 6.35 |
| MUZ-FT35VGHZ | 30 | 15 | | |
| MUZ-FT50VGHZ | | | | |

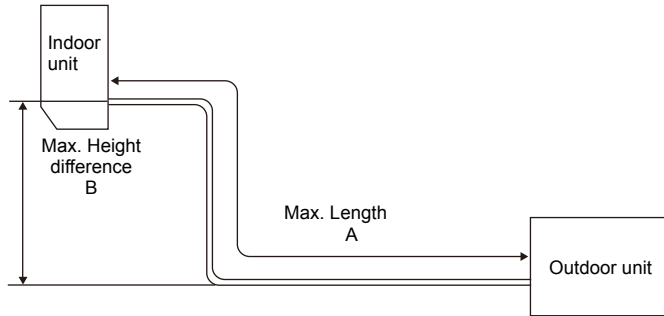

ADDITIONAL REFRIGERANT CHARGE (R32: g)

| Model | Outdoor unit precharged | Refrigerant piping length (one way) | | | | | | | | | |
|--------------|-------------------------|-------------------------------------|------|------|------|------|------|------|------|------|------|
| | | 7 m | 11 m | 12 m | 13 m | 14 m | 15 m | 16 m | 17 m | 18 m | 20 m |
| MUZ-FT25VGHZ | 850 | - | 70 | 90 | 110 | 130 | 150 | 170 | 190 | 210 | 250 |

Calculation: X g = 20 g/m × (Refrigerant piping length(m) - 7.5)

| Model | Outdoor unit precharged | Refrigerant piping length (one way) | | | | | | | | | | | |
|--------------|-------------------------|-------------------------------------|------|------|------|------|------|------|------|------|------|------|------|
| | | 7 m | 11 m | 12 m | 13 m | 14 m | 15 m | 16 m | 17 m | 18 m | 20 m | 25 m | 30 m |
| MUZ-FT35VGHZ | 950 | - | 70 | 90 | 110 | 130 | 150 | 170 | 190 | 210 | 250 | 350 | 450 |
| MUZ-FT50VGHZ | 950 | - | 70 | 90 | 110 | 130 | 150 | 170 | 190 | 210 | 250 | 350 | 450 |

Calculation: X g = 20 g/m × (Refrigerant piping length(m) - 7.5)

MUZ-FT25VGHZ MUZ-FT35VGHZ MUZ-FT50VGHZ

The standard specifications apply only to the operation of the air conditioner under normal conditions. Since operating conditions vary according to the areas where these units are installed, the following information has been provided to clarify the operating characteristics of the air conditioner under the conditions indicated by the performance curve.

(1) GUARANTEED VOLTAGE

198 ~ 264V, 50 Hz

(2) AIRFLOW

Airflow should be set at MAX.

(3) MAIN READINGS

| | | |
|--|---------|-----------|
| (1) Indoor intake air wet-bulb temperature: | °C [WB] | } Cooling |
| (2) Indoor outlet air wet-bulb temperature: | °C [WB] | |
| (3) Outdoor intake air dry-bulb temperature: | °C [DB] | |
| (4) Total input: | W | |
| (5) Indoor intake air dry-bulb temperature: | °C [DB] | } Heating |
| (6) Outdoor intake air wet-bulb temperature: | °C [WB] | |
| (7) Total input: | W | |

Indoor air wet and dry bulb temperature difference on the left side of the following chart shows the difference between the indoor intake air wet and dry bulb temperature and the indoor outlet air wet and dry bulb temperature for your reference at service.

(4) GUARANTEED OUTDOOR TEMPERATURE

COOLING (DB/WB): -10/ - ~ 46/ -

HEATING (DB/WB): -25/ - ~ 24/18

How to measure the indoor air wet and dry bulb temperature difference

1. Attach at least 2 sets of wet and dry bulb thermometers to the indoor air intake as shown in the figure, and at least 2 sets of wet and dry bulb thermometers to the indoor air outlet. The thermometers must be attached to the position where air speed is high.
2. Attach at least 2 sets of wet and dry bulb thermometers to the outdoor air intake.
Cover the thermometers to prevent direct rays of the sun.
3. Check that the air filter is cleaned.
4. Open windows and doors of room.
5. Press the EMERGENCY OPERATION switch once (twice) to start the EMERGENCY COOL (HEAT) MODE.
6. When system stabilizes after more than 15 minutes, measure temperature and take an average temperature.
7. 10 minutes later, measure temperature again and check that the temperature does not change.

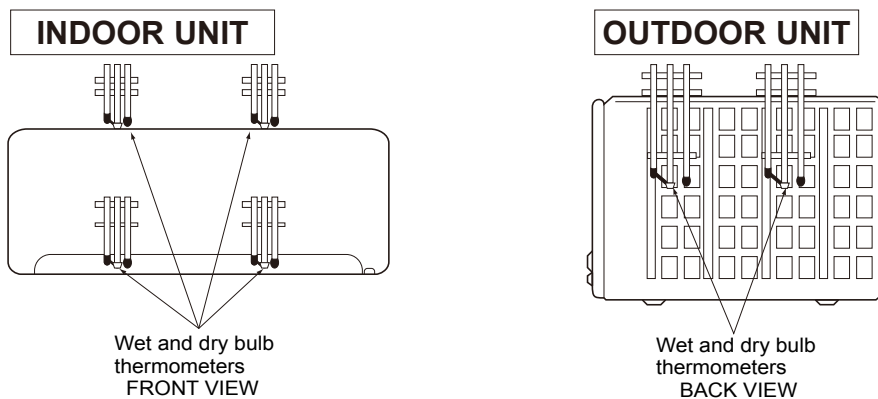

9-1. CAPACITY AND INPUT CURVES

| | | | |
|---|--------------|--------------|--------------|
| Indoor air Wet-bulb temperature difference (°C) | 5.4 | 7.3 | 11.2 |
| | 5.0 | 6.8 | 10.3 |
| | 4.6 | 6.2 | 9.4 |
| | 4.2 | 5.7 | 8.6 |
| | 3.8 | 5.2 | 7.7 |
| | 3.5 | 4.7 | 6.9 |
| 3.1 | 4.1 | 6.1 | |
| | MUZ-FT25VGHZ | MUZ-FT35VGHZ | MUZ-FT50VGHZ |

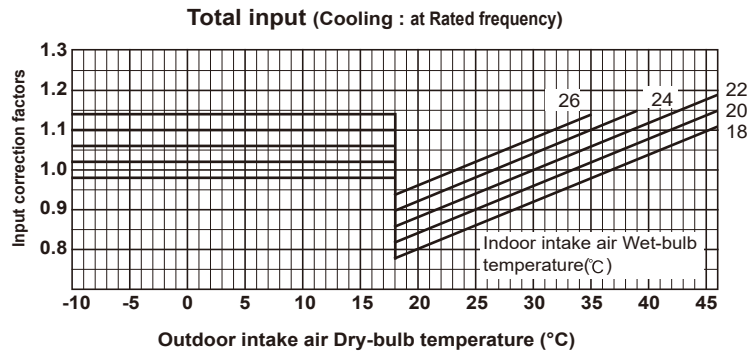
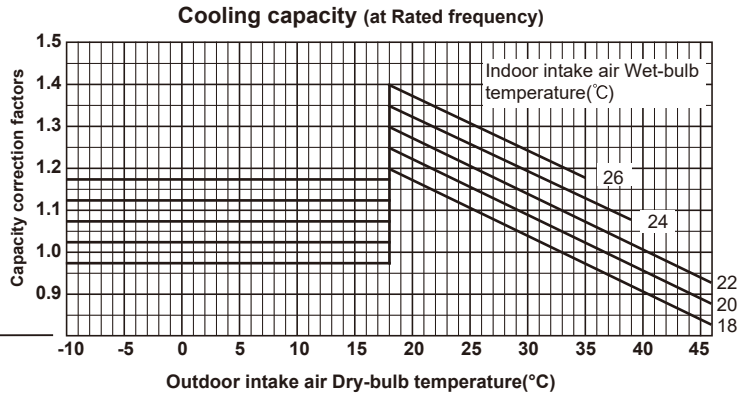

| | | | |
|---|--------------|--------------|--------------|
| Indoor air Dry-bulb temperature difference (°C) | 15.9 | 17.8 | 21.1 |
| | 14.6 | 16.4 | 19.5 |
| | 13.4 | 15.1 | 17.8 |
| | 12.2 | 13.7 | 16.2 |
| | 11.0 | 12.3 | 14.6 |
| | 9.8 | 10.9 | 13.0 |
| 8.5 | 9.6 | 11.4 | |
| 7.3 | 8.2 | 9.7 | |
| 6.1 | 6.8 | 8.1 | |
| 4.9 | 5.5 | 6.5 | |
| | MUZ-FT25VGHZ | MUZ-FT35VGHZ | MUZ-FT50VGHZ |

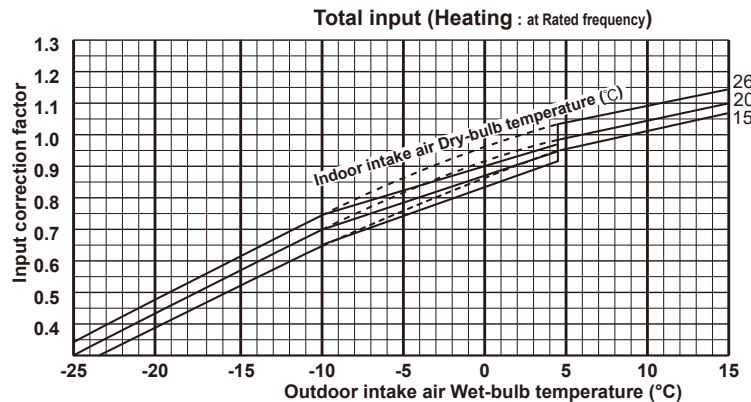
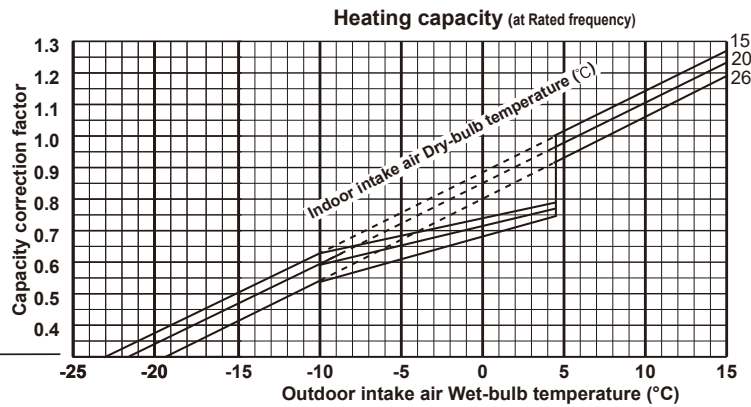

NOTE: The above broken lines are for the heating operation without any frost and defrost operation.

9-2. CAPACITY AND INPUT CORRECTION BY OPERATIONAL FREQUENCY OF COMPRESSOR

MUZ-FT25VGHZ

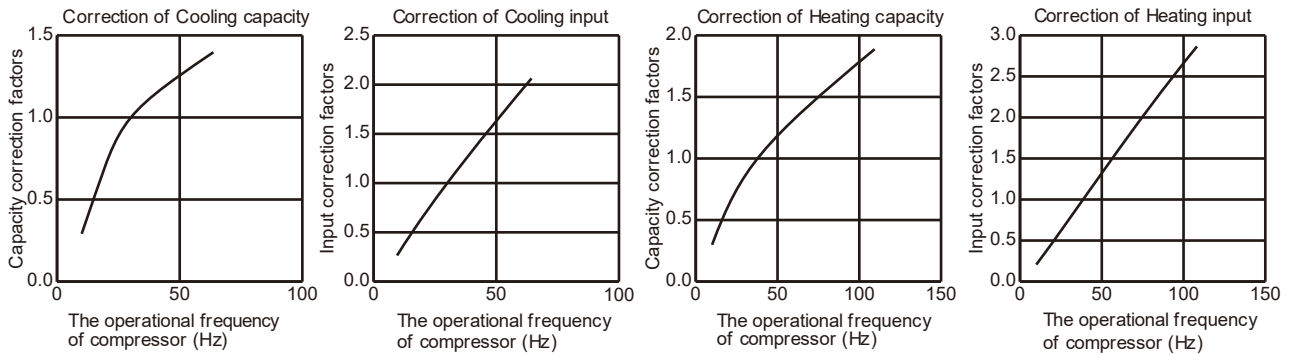

MUZ-FT35VGHZ

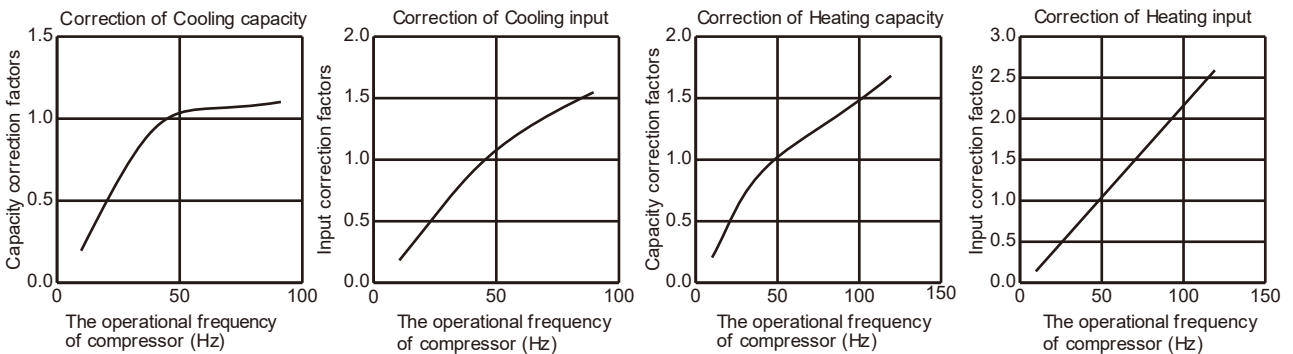

MUZ-FT50VGHZ

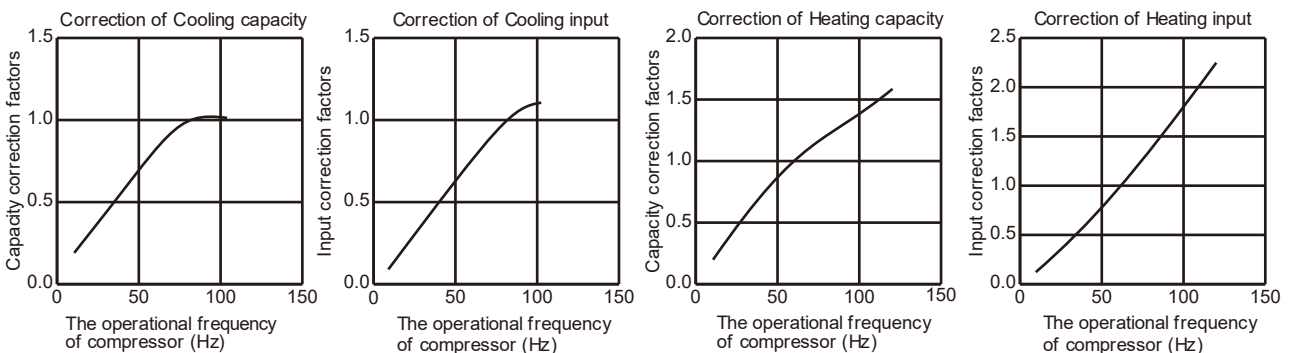

9-3. HOW TO OPERATE FIXED-FREQUENCY OPERATION

<Test run operation>

1. Press EMERGENCY OPERATION switch to start COOL or HEAT mode (COOL: Press once, HEAT: Press twice).
2. Test run operation starts and continues to operate for 30 minutes.
3. Compressor operates at rated frequency in COOL mode or 58 Hz in HEAT mode.
4. Indoor fan operates at High speed.
5. After 30 minutes, test run operation finishes and EMERGENCY OPERATION starts (operation frequency of compressor varies).
6. To cancel test run operation (EMERGENCY OPERATION), press EMERGENCY OPERATION switch or any button on remote controller.

9-4. OUTDOOR LOW PRESSURE AND OUTDOOR UNIT CURRENT

COOL operation

- ① Both indoor and outdoor unit are under the same temperature/ humidity condition.
- ② Operation: Test run operation (Refer to 9-3.)

| Dry-bulb temperature (°C) | Relative humidity (%) |
|---------------------------|-----------------------|
| 20 | 50 |
| 25 | 60 |
| 30 | 70 |

Outdoor low pressure

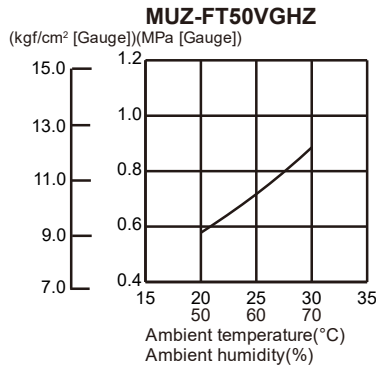
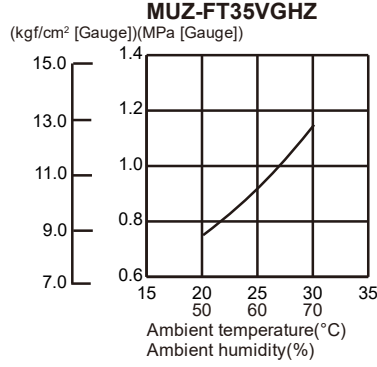
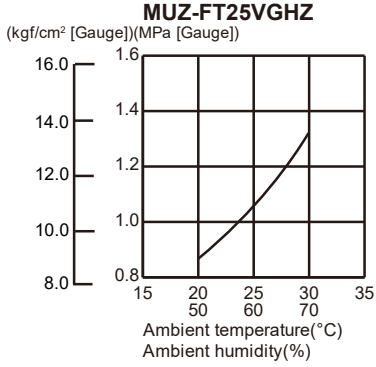

NOTE:

The unit of pressure has been changed to MPa on the international system of units (SI unit system)
The conversion factor is: **1 (MPa [Gauge]) = 10.2 (kgf/cm² [Gauge])**

Outdoor unit current

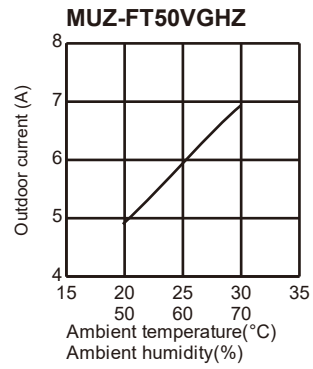
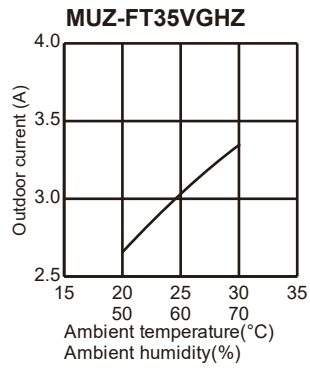
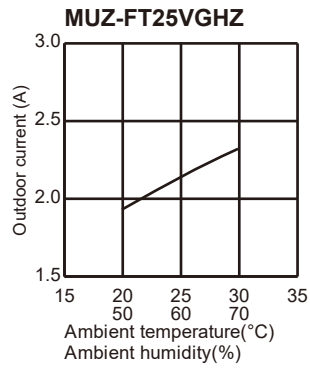

HEAT operation

① Condition:

| | Indoor | Outdoor | | | |
|---------------------------|--------|---------|---|----|------|
| Dry bulb temperature (°C) | 20.0 | 2 | 7 | 15 | 20.0 |
| Wet bulb temperature (°C) | 14.5 | 1 | 6 | 12 | 14.5 |

② Operation: Test run operation (Refer to 9-3.)

Outdoor unit current

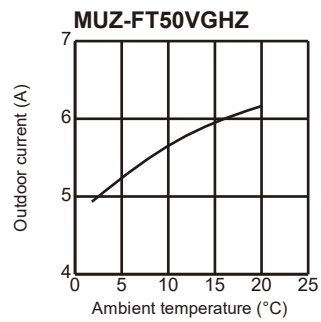
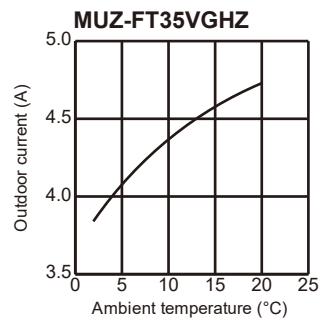
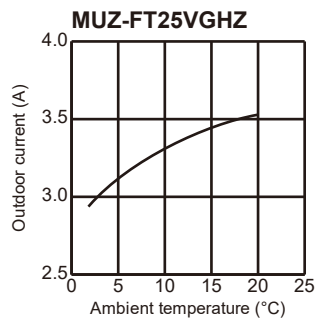

PERFORMANCE DATA COOL operation at Rated frequency

MUZ-FT25VGHZ

CAPACITY: 2.5 kW

SHF: 0.95

INPUT: 580 W

| INDOOR DB (°C) | INDOOR WB (°C) | OUTDOOR DB (°C) | | | | | | | | | | | | | | | |
|----------------|----------------|-----------------|------|------|-------|------|------|------|-------|------|------|------|-------|------|------|------|-------|
| | | 21 | | | | 25 | | | | 27 | | | | 30 | | | |
| | | Q | SHC | SHF | INPUT | Q | SHC | SHF | INPUT | Q | SHC | SHF | INPUT | Q | SHC | SHF | INPUT |
| 21 | 18 | 2.94 | 2.26 | 0.77 | 464 | 2.81 | 2.17 | 0.77 | 487 | 2.70 | 2.08 | 0.77 | 510 | 2.60 | 2.00 | 0.77 | 534 |
| 21 | 20 | 3.06 | 1.99 | 0.65 | 487 | 2.94 | 1.91 | 0.65 | 516 | 2.85 | 1.85 | 0.65 | 528 | 2.75 | 1.79 | 0.65 | 551 |
| 22 | 18 | 2.94 | 2.38 | 0.81 | 464 | 2.81 | 2.28 | 0.81 | 487 | 2.70 | 2.19 | 0.81 | 510 | 2.60 | 2.11 | 0.81 | 534 |
| 22 | 20 | 3.06 | 2.11 | 0.69 | 487 | 2.94 | 2.03 | 0.69 | 516 | 2.85 | 1.97 | 0.69 | 528 | 2.75 | 1.90 | 0.69 | 551 |
| 22 | 22 | 3.19 | 1.82 | 0.57 | 505 | 3.08 | 1.75 | 0.57 | 537 | 3.00 | 1.71 | 0.57 | 551 | 2.88 | 1.64 | 0.57 | 574 |
| 23 | 18 | 2.94 | 2.50 | 0.85 | 464 | 2.81 | 2.39 | 0.85 | 487 | 2.70 | 2.30 | 0.85 | 510 | 2.60 | 2.21 | 0.85 | 534 |
| 23 | 20 | 3.06 | 2.24 | 0.73 | 487 | 2.94 | 2.14 | 0.73 | 516 | 2.85 | 2.08 | 0.73 | 528 | 2.75 | 2.01 | 0.73 | 551 |
| 23 | 22 | 3.19 | 1.94 | 0.61 | 505 | 3.08 | 1.88 | 0.61 | 537 | 3.00 | 1.83 | 0.61 | 551 | 2.88 | 1.75 | 0.61 | 574 |
| 24 | 18 | 2.94 | 2.61 | 0.89 | 464 | 2.81 | 2.50 | 0.89 | 487 | 2.70 | 2.40 | 0.89 | 510 | 2.60 | 2.31 | 0.89 | 534 |
| 24 | 20 | 3.06 | 2.36 | 0.77 | 487 | 2.94 | 2.26 | 0.77 | 516 | 2.85 | 2.19 | 0.77 | 528 | 2.75 | 2.12 | 0.77 | 551 |
| 24 | 22 | 3.19 | 2.07 | 0.65 | 505 | 3.08 | 2.00 | 0.65 | 537 | 3.00 | 1.95 | 0.65 | 551 | 2.88 | 1.87 | 0.65 | 574 |
| 24 | 24 | 3.35 | 1.78 | 0.53 | 528 | 3.23 | 1.71 | 0.53 | 557 | 3.15 | 1.67 | 0.53 | 574 | 3.05 | 1.62 | 0.53 | 603 |
| 25 | 18 | 2.94 | 2.73 | 0.93 | 464 | 2.81 | 2.62 | 0.93 | 487 | 2.70 | 2.51 | 0.93 | 510 | 2.60 | 2.42 | 0.93 | 534 |
| 25 | 20 | 3.06 | 2.48 | 0.81 | 487 | 2.94 | 2.38 | 0.81 | 516 | 2.85 | 2.31 | 0.81 | 528 | 2.75 | 2.23 | 0.81 | 551 |
| 25 | 22 | 3.19 | 2.20 | 0.69 | 505 | 3.08 | 2.12 | 0.69 | 537 | 3.00 | 2.07 | 0.69 | 551 | 2.88 | 1.98 | 0.69 | 574 |
| 25 | 24 | 3.35 | 1.91 | 0.57 | 528 | 3.23 | 1.84 | 0.57 | 557 | 3.15 | 1.80 | 0.57 | 574 | 3.05 | 1.74 | 0.57 | 603 |
| 26 | 18 | 2.94 | 2.85 | 0.97 | 464 | 2.81 | 2.73 | 0.97 | 487 | 2.70 | 2.62 | 0.97 | 510 | 2.60 | 2.52 | 0.97 | 534 |
| 26 | 20 | 3.06 | 2.60 | 0.85 | 487 | 2.94 | 2.50 | 0.85 | 516 | 2.85 | 2.42 | 0.85 | 528 | 2.75 | 2.34 | 0.85 | 551 |
| 26 | 22 | 3.19 | 2.33 | 0.73 | 505 | 3.08 | 2.24 | 0.73 | 537 | 3.00 | 2.19 | 0.73 | 551 | 2.88 | 2.10 | 0.73 | 574 |
| 26 | 24 | 3.35 | 2.04 | 0.61 | 528 | 3.23 | 1.97 | 0.61 | 557 | 3.15 | 1.92 | 0.61 | 574 | 3.05 | 1.86 | 0.61 | 603 |
| 26 | 26 | 3.45 | 1.69 | 0.49 | 557 | 3.35 | 1.64 | 0.49 | 586 | 3.30 | 1.62 | 0.49 | 603 | 3.20 | 1.57 | 0.49 | 621 |
| 27 | 18 | 2.94 | 2.94 | 1.00 | 464 | 2.81 | 2.81 | 1.00 | 487 | 2.70 | 2.70 | 1.00 | 510 | 2.60 | 2.60 | 1.00 | 534 |
| 27 | 20 | 3.06 | 2.73 | 0.89 | 487 | 2.94 | 2.61 | 0.89 | 516 | 2.85 | 2.54 | 0.89 | 528 | 2.75 | 2.45 | 0.89 | 551 |
| 27 | 22 | 3.19 | 2.45 | 0.77 | 505 | 3.08 | 2.37 | 0.77 | 537 | 3.00 | 2.31 | 0.77 | 551 | 2.88 | 2.21 | 0.77 | 574 |
| 27 | 24 | 3.35 | 2.18 | 0.65 | 528 | 3.23 | 2.10 | 0.65 | 557 | 3.15 | 2.05 | 0.65 | 574 | 3.05 | 1.98 | 0.65 | 603 |
| 27 | 26 | 3.45 | 1.83 | 0.53 | 557 | 3.35 | 1.78 | 0.53 | 586 | 3.30 | 1.75 | 0.53 | 603 | 3.20 | 1.70 | 0.53 | 621 |
| 28 | 18 | 2.94 | 2.94 | 1.00 | 464 | 2.81 | 2.81 | 1.00 | 487 | 2.70 | 2.70 | 1.00 | 510 | 2.60 | 2.60 | 1.00 | 534 |
| 28 | 20 | 3.06 | 2.85 | 0.93 | 487 | 2.94 | 2.73 | 0.93 | 516 | 2.85 | 2.65 | 0.93 | 528 | 2.75 | 2.56 | 0.93 | 551 |
| 28 | 22 | 3.19 | 2.58 | 0.81 | 505 | 3.08 | 2.49 | 0.81 | 537 | 3.00 | 2.43 | 0.81 | 551 | 2.88 | 2.33 | 0.81 | 574 |
| 28 | 24 | 3.35 | 2.31 | 0.69 | 528 | 3.23 | 2.23 | 0.69 | 557 | 3.15 | 2.17 | 0.69 | 574 | 3.05 | 2.10 | 0.69 | 603 |
| 28 | 26 | 3.45 | 1.97 | 0.57 | 557 | 3.35 | 1.91 | 0.57 | 586 | 3.30 | 1.88 | 0.57 | 603 | 3.20 | 1.82 | 0.57 | 621 |
| 29 | 18 | 2.94 | 2.94 | 1.00 | 464 | 2.81 | 2.81 | 1.00 | 487 | 2.70 | 2.70 | 1.00 | 510 | 2.60 | 2.60 | 1.00 | 534 |
| 29 | 20 | 3.06 | 2.97 | 0.97 | 487 | 2.94 | 2.85 | 0.97 | 516 | 2.85 | 2.76 | 0.97 | 528 | 2.75 | 2.67 | 0.97 | 551 |
| 29 | 22 | 3.19 | 2.71 | 0.85 | 505 | 3.08 | 2.61 | 0.85 | 537 | 3.00 | 2.55 | 0.85 | 551 | 2.88 | 2.44 | 0.85 | 574 |
| 29 | 24 | 3.35 | 2.45 | 0.73 | 528 | 3.23 | 2.35 | 0.73 | 557 | 3.15 | 2.30 | 0.73 | 574 | 3.05 | 2.23 | 0.73 | 603 |
| 29 | 26 | 3.45 | 2.10 | 0.61 | 557 | 3.35 | 2.04 | 0.61 | 586 | 3.30 | 2.01 | 0.61 | 603 | 3.20 | 1.95 | 0.61 | 621 |
| 30 | 18 | 2.94 | 2.94 | 1.00 | 464 | 2.81 | 2.81 | 1.00 | 487 | 2.70 | 2.70 | 1.00 | 510 | 2.60 | 2.60 | 1.00 | 534 |
| 30 | 20 | 3.06 | 3.06 | 1.00 | 487 | 2.94 | 2.94 | 1.00 | 516 | 2.85 | 2.85 | 1.00 | 528 | 2.75 | 2.75 | 1.00 | 551 |
| 30 | 22 | 3.19 | 2.84 | 0.89 | 505 | 3.08 | 2.74 | 0.89 | 537 | 3.00 | 2.67 | 0.89 | 551 | 2.88 | 2.56 | 0.89 | 574 |
| 30 | 24 | 3.35 | 2.58 | 0.77 | 528 | 3.23 | 2.48 | 0.77 | 557 | 3.15 | 2.43 | 0.77 | 574 | 3.05 | 2.35 | 0.77 | 603 |
| 30 | 26 | 3.45 | 2.24 | 0.65 | 557 | 3.35 | 2.18 | 0.65 | 586 | 3.30 | 2.15 | 0.65 | 603 | 3.20 | 2.08 | 0.65 | 621 |
| 31 | 18 | 2.94 | 2.94 | 1.00 | 464 | 2.81 | 2.81 | 1.00 | 487 | 2.70 | 2.70 | 1.00 | 510 | 2.60 | 2.60 | 1.00 | 534 |
| 31 | 20 | 3.06 | 3.06 | 1.00 | 487 | 2.94 | 2.94 | 1.00 | 516 | 2.85 | 2.85 | 1.00 | 528 | 2.75 | 2.75 | 1.00 | 551 |
| 31 | 22 | 3.19 | 2.96 | 0.93 | 505 | 3.08 | 2.86 | 0.93 | 537 | 3.00 | 2.79 | 0.93 | 551 | 2.88 | 2.67 | 0.93 | 574 |
| 31 | 24 | 3.35 | 2.71 | 0.81 | 528 | 3.23 | 2.61 | 0.81 | 557 | 3.15 | 2.55 | 0.81 | 574 | 3.05 | 2.47 | 0.81 | 603 |
| 31 | 26 | 3.45 | 2.38 | 0.69 | 557 | 3.35 | 2.31 | 0.69 | 586 | 3.30 | 2.28 | 0.69 | 603 | 3.20 | 2.21 | 0.69 | 621 |
| 32 | 18 | 2.94 | 2.94 | 1.00 | 464 | 2.81 | 2.81 | 1.00 | 487 | 2.70 | 2.70 | 1.00 | 510 | 2.60 | 2.60 | 1.00 | 534 |
| 32 | 20 | 3.06 | 3.06 | 1.00 | 487 | 2.94 | 2.94 | 1.00 | 516 | 2.85 | 2.85 | 1.00 | 528 | 2.75 | 2.75 | 1.00 | 551 |
| 32 | 22 | 3.19 | 3.09 | 0.97 | 505 | 3.08 | 2.98 | 0.97 | 537 | 3.00 | 2.91 | 0.97 | 551 | 2.88 | 2.79 | 0.97 | 574 |
| 32 | 24 | 3.35 | 2.85 | 0.85 | 528 | 3.23 | 2.74 | 0.85 | 557 | 3.15 | 2.68 | 0.85 | 574 | 3.05 | 2.59 | 0.85 | 603 |
| 32 | 26 | 3.45 | 2.52 | 0.73 | 557 | 3.35 | 2.45 | 0.73 | 586 | 3.30 | 2.41 | 0.73 | 603 | 3.20 | 2.34 | 0.73 | 621 |

NOTE Q : Total capacity (kW) SHF : Sensible heat factor DB : Dry-bulb temperature
 SHC : Sensible heat capacity (kW) INPUT : Total power input (W) WB : Wet-bulb temperature

PERFORMANCE DATA COOL operation at Rated frequency
MUZ-FT25VGHZ

CAPACITY: 2.5 kW SHF: 0.95 INPUT: 580 W

| INDOOR DB (°C) | INDOOR WB (°C) | OUTDOOR DB (°C) | | | | | | | | | | | |
|----------------|----------------|-----------------|------|------|-------|------|------|------|-------|------|------|------|-------|
| | | 35 | | | | 40 | | | | 46 | | | |
| | | Q | SHC | SHF | INPUT | Q | SHC | SHF | INPUT | Q | SHC | SHF | INPUT |
| 21 | 18 | 2.45 | 1.89 | 0.77 | 568 | 2.25 | 1.73 | 0.77 | 603 | 2.08 | 1.60 | 0.77 | 626 |
| 21 | 20 | 2.58 | 1.67 | 0.65 | 592 | 2.40 | 1.56 | 0.65 | 621 | 2.23 | 1.45 | 0.65 | 655 |
| 22 | 18 | 2.45 | 1.98 | 0.81 | 568 | 2.25 | 1.82 | 0.81 | 603 | 2.08 | 1.68 | 0.81 | 626 |
| 22 | 20 | 2.58 | 1.78 | 0.69 | 592 | 2.40 | 1.66 | 0.69 | 621 | 2.23 | 1.54 | 0.69 | 655 |
| 22 | 22 | 2.73 | 1.55 | 0.57 | 615 | 2.55 | 1.45 | 0.57 | 650 | 2.38 | 1.35 | 0.57 | 673 |
| 23 | 18 | 2.45 | 2.08 | 0.85 | 568 | 2.25 | 1.91 | 0.85 | 603 | 2.08 | 1.76 | 0.85 | 626 |
| 23 | 20 | 2.58 | 1.88 | 0.73 | 592 | 2.40 | 1.75 | 0.73 | 621 | 2.23 | 1.62 | 0.73 | 655 |
| 23 | 22 | 2.73 | 1.66 | 0.61 | 615 | 2.55 | 1.56 | 0.61 | 650 | 2.38 | 1.45 | 0.61 | 673 |
| 24 | 18 | 2.45 | 2.18 | 0.89 | 568 | 2.25 | 2.00 | 0.89 | 603 | 2.08 | 1.85 | 0.89 | 626 |
| 24 | 20 | 2.58 | 1.98 | 0.77 | 592 | 2.40 | 1.85 | 0.77 | 621 | 2.23 | 1.71 | 0.77 | 655 |
| 24 | 22 | 2.73 | 1.77 | 0.65 | 615 | 2.55 | 1.66 | 0.65 | 650 | 2.38 | 1.54 | 0.65 | 673 |
| 24 | 24 | 2.88 | 1.52 | 0.53 | 638 | 2.70 | 1.43 | 0.53 | 667 | 2.55 | 1.35 | 0.53 | 696 |
| 25 | 18 | 2.45 | 2.28 | 0.93 | 568 | 2.25 | 2.09 | 0.93 | 603 | 2.08 | 1.93 | 0.93 | 626 |
| 25 | 20 | 2.58 | 2.09 | 0.81 | 592 | 2.40 | 1.94 | 0.81 | 621 | 2.23 | 1.80 | 0.81 | 655 |
| 25 | 22 | 2.73 | 1.88 | 0.69 | 615 | 2.55 | 1.76 | 0.69 | 650 | 2.38 | 1.64 | 0.69 | 673 |
| 25 | 24 | 2.88 | 1.64 | 0.57 | 638 | 2.70 | 1.54 | 0.57 | 667 | 2.55 | 1.45 | 0.57 | 696 |
| 26 | 18 | 2.45 | 2.38 | 0.97 | 568 | 2.25 | 2.18 | 0.97 | 603 | 2.08 | 2.01 | 0.97 | 626 |
| 26 | 20 | 2.58 | 2.19 | 0.85 | 592 | 2.40 | 2.04 | 0.85 | 621 | 2.23 | 1.89 | 0.85 | 655 |
| 26 | 22 | 2.73 | 1.99 | 0.73 | 615 | 2.55 | 1.86 | 0.73 | 650 | 2.38 | 1.73 | 0.73 | 673 |
| 26 | 24 | 2.88 | 1.75 | 0.61 | 638 | 2.70 | 1.65 | 0.61 | 667 | 2.55 | 1.56 | 0.61 | 696 |
| 26 | 26 | 3.03 | 1.48 | 0.49 | 661 | 2.85 | 1.40 | 0.49 | 690 | 2.68 | 1.31 | 0.49 | 719 |
| 27 | 18 | 2.45 | 2.45 | 1.00 | 568 | 2.25 | 2.25 | 1.00 | 603 | 2.08 | 2.08 | 1.00 | 626 |
| 27 | 20 | 2.58 | 2.29 | 0.89 | 592 | 2.40 | 2.14 | 0.89 | 621 | 2.23 | 1.98 | 0.89 | 655 |
| 27 | 22 | 2.73 | 2.10 | 0.77 | 615 | 2.55 | 1.96 | 0.77 | 650 | 2.38 | 1.83 | 0.77 | 673 |
| 27 | 24 | 2.88 | 1.87 | 0.65 | 638 | 2.70 | 1.76 | 0.65 | 667 | 2.55 | 1.66 | 0.65 | 696 |
| 27 | 26 | 3.03 | 1.60 | 0.53 | 661 | 2.85 | 1.51 | 0.53 | 690 | 2.68 | 1.42 | 0.53 | 719 |
| 28 | 18 | 2.45 | 2.45 | 1.00 | 568 | 2.25 | 2.25 | 1.00 | 603 | 2.08 | 2.08 | 1.00 | 626 |
| 28 | 20 | 2.58 | 2.39 | 0.93 | 592 | 2.40 | 2.23 | 0.93 | 621 | 2.23 | 2.07 | 0.93 | 655 |
| 28 | 22 | 2.73 | 2.21 | 0.81 | 615 | 2.55 | 2.07 | 0.81 | 650 | 2.38 | 1.92 | 0.81 | 673 |
| 28 | 24 | 2.88 | 1.98 | 0.69 | 638 | 2.70 | 1.86 | 0.69 | 667 | 2.55 | 1.76 | 0.69 | 696 |
| 28 | 26 | 3.03 | 1.72 | 0.57 | 661 | 2.85 | 1.62 | 0.57 | 690 | 2.68 | 1.52 | 0.57 | 719 |
| 29 | 18 | 2.45 | 2.45 | 1.00 | 568 | 2.25 | 2.25 | 1.00 | 603 | 2.08 | 2.08 | 1.00 | 626 |
| 29 | 20 | 2.58 | 2.50 | 0.97 | 592 | 2.40 | 2.33 | 0.97 | 621 | 2.23 | 2.16 | 0.97 | 655 |
| 29 | 22 | 2.73 | 2.32 | 0.85 | 615 | 2.55 | 2.17 | 0.85 | 650 | 2.38 | 2.02 | 0.85 | 673 |
| 29 | 24 | 2.88 | 2.10 | 0.73 | 638 | 2.70 | 1.97 | 0.73 | 667 | 2.55 | 1.86 | 0.73 | 696 |
| 29 | 26 | 3.03 | 1.85 | 0.61 | 661 | 2.85 | 1.74 | 0.61 | 690 | 2.68 | 1.63 | 0.61 | 719 |
| 30 | 18 | 2.45 | 2.45 | 1.00 | 568 | 2.25 | 2.25 | 1.00 | 603 | 2.08 | 2.08 | 1.00 | 626 |
| 30 | 20 | 2.58 | 2.58 | 1.00 | 592 | 2.40 | 2.40 | 1.00 | 621 | 2.23 | 2.23 | 1.00 | 655 |
| 30 | 22 | 2.73 | 2.43 | 0.89 | 615 | 2.55 | 2.27 | 0.89 | 650 | 2.38 | 2.11 | 0.89 | 673 |
| 30 | 24 | 2.88 | 2.21 | 0.77 | 638 | 2.70 | 2.08 | 0.77 | 667 | 2.55 | 1.96 | 0.77 | 696 |
| 30 | 26 | 3.03 | 1.97 | 0.65 | 661 | 2.85 | 1.85 | 0.65 | 690 | 2.68 | 1.74 | 0.65 | 719 |
| 31 | 18 | 2.45 | 2.45 | 1.00 | 568 | 2.25 | 2.25 | 1.00 | 603 | 2.08 | 2.08 | 1.00 | 626 |
| 31 | 20 | 2.58 | 2.58 | 1.00 | 592 | 2.40 | 2.40 | 1.00 | 621 | 2.23 | 2.23 | 1.00 | 655 |
| 31 | 22 | 2.73 | 2.53 | 0.93 | 615 | 2.55 | 2.37 | 0.93 | 650 | 2.38 | 2.21 | 0.93 | 673 |
| 31 | 24 | 2.88 | 2.33 | 0.81 | 638 | 2.70 | 2.19 | 0.81 | 667 | 2.55 | 2.07 | 0.81 | 696 |
| 31 | 26 | 3.03 | 2.09 | 0.69 | 661 | 2.85 | 1.97 | 0.69 | 690 | 2.68 | 1.85 | 0.69 | 719 |
| 32 | 18 | 2.45 | 2.45 | 1.00 | 568 | 2.25 | 2.25 | 1.00 | 603 | 2.08 | 2.08 | 1.00 | 626 |
| 32 | 20 | 2.58 | 2.58 | 1.00 | 592 | 2.40 | 2.40 | 1.00 | 621 | 2.23 | 2.23 | 1.00 | 655 |
| 32 | 22 | 2.73 | 2.64 | 0.97 | 615 | 2.55 | 2.47 | 0.97 | 650 | 2.38 | 2.30 | 0.97 | 673 |
| 32 | 24 | 2.88 | 2.44 | 0.85 | 638 | 2.70 | 2.30 | 0.85 | 667 | 2.55 | 2.17 | 0.85 | 696 |
| 32 | 26 | 3.03 | 2.21 | 0.73 | 661 | 2.85 | 2.08 | 0.73 | 690 | 2.68 | 1.95 | 0.73 | 719 |

NOTE Q : Total capacity (kW) SHF : Sensible heat factor DB : Dry-bulb temperature
 SHC : Sensible heat capacity (kW) INPUT : Total power input (W) WB : Wet-bulb temperature

PERFORMANCE DATA COOL operation at Rated frequency

MUZ-FT35VGHZ

CAPACITY: 3.5 kW

SHF: 0.8

INPUT: 910 W

| INDOOR DB (°C) | INDOOR WB (°C) | OUTDOOR DB (°C) | | | | | | | | | | | | | | | |
|----------------|----------------|-----------------|------|------|-------|------|------|------|-------|------|------|------|-------|------|------|------|-------|
| | | 21 | | | | 25 | | | | 27 | | | | 30 | | | |
| | | Q | SHC | SHF | INPUT | Q | SHC | SHF | INPUT | Q | SHC | SHF | INPUT | Q | SHC | SHF | INPUT |
| 21 | 18 | 4.11 | 2.55 | 0.62 | 728 | 3.94 | 2.44 | 0.62 | 764 | 3.78 | 2.34 | 0.62 | 801 | 3.64 | 2.26 | 0.62 | 837 |
| 21 | 20 | 4.29 | 2.14 | 0.50 | 764 | 4.11 | 2.06 | 0.50 | 810 | 3.99 | 2.00 | 0.50 | 828 | 3.85 | 1.93 | 0.50 | 865 |
| 22 | 18 | 4.11 | 2.71 | 0.66 | 728 | 3.94 | 2.60 | 0.66 | 764 | 3.78 | 2.49 | 0.66 | 801 | 3.64 | 2.40 | 0.66 | 837 |
| 22 | 20 | 4.29 | 2.32 | 0.54 | 764 | 4.11 | 2.22 | 0.54 | 810 | 3.99 | 2.15 | 0.54 | 828 | 3.85 | 2.08 | 0.54 | 865 |
| 22 | 22 | 4.46 | 1.87 | 0.42 | 792 | 4.31 | 1.81 | 0.42 | 842 | 4.20 | 1.76 | 0.42 | 865 | 4.03 | 1.69 | 0.42 | 901 |
| 23 | 18 | 4.11 | 2.88 | 0.70 | 728 | 3.94 | 2.76 | 0.70 | 764 | 3.78 | 2.65 | 0.70 | 801 | 3.64 | 2.55 | 0.70 | 837 |
| 23 | 20 | 4.29 | 2.49 | 0.58 | 764 | 4.11 | 2.39 | 0.58 | 810 | 3.99 | 2.31 | 0.58 | 828 | 3.85 | 2.23 | 0.58 | 865 |
| 23 | 22 | 4.46 | 2.05 | 0.46 | 792 | 4.31 | 1.98 | 0.46 | 842 | 4.20 | 1.93 | 0.46 | 865 | 4.03 | 1.85 | 0.46 | 901 |
| 24 | 18 | 4.11 | 3.04 | 0.74 | 728 | 3.94 | 2.91 | 0.74 | 764 | 3.78 | 2.80 | 0.74 | 801 | 3.64 | 2.69 | 0.74 | 837 |
| 24 | 20 | 4.29 | 2.66 | 0.62 | 764 | 4.11 | 2.55 | 0.62 | 810 | 3.99 | 2.47 | 0.62 | 828 | 3.85 | 2.39 | 0.62 | 865 |
| 24 | 22 | 4.46 | 2.23 | 0.50 | 792 | 4.31 | 2.15 | 0.50 | 842 | 4.20 | 2.10 | 0.50 | 865 | 4.03 | 2.01 | 0.50 | 901 |
| 24 | 24 | 4.69 | 1.78 | 0.38 | 828 | 4.52 | 1.72 | 0.38 | 874 | 4.41 | 1.68 | 0.38 | 901 | 4.27 | 1.62 | 0.38 | 946 |
| 25 | 18 | 4.11 | 3.21 | 0.78 | 728 | 3.94 | 3.07 | 0.78 | 764 | 3.78 | 2.95 | 0.78 | 801 | 3.64 | 2.84 | 0.78 | 837 |
| 25 | 20 | 4.29 | 2.83 | 0.66 | 764 | 4.11 | 2.71 | 0.66 | 810 | 3.99 | 2.63 | 0.66 | 828 | 3.85 | 2.54 | 0.66 | 865 |
| 25 | 22 | 4.46 | 2.41 | 0.54 | 792 | 4.31 | 2.32 | 0.54 | 842 | 4.20 | 2.27 | 0.54 | 865 | 4.03 | 2.17 | 0.54 | 901 |
| 25 | 24 | 4.69 | 1.97 | 0.42 | 828 | 4.52 | 1.90 | 0.42 | 874 | 4.41 | 1.85 | 0.42 | 901 | 4.27 | 1.79 | 0.42 | 946 |
| 26 | 18 | 4.11 | 3.37 | 0.82 | 728 | 3.94 | 3.23 | 0.82 | 764 | 3.78 | 3.10 | 0.82 | 801 | 3.64 | 2.98 | 0.82 | 837 |
| 26 | 20 | 4.29 | 3.00 | 0.70 | 764 | 4.11 | 2.88 | 0.70 | 810 | 3.99 | 2.79 | 0.70 | 828 | 3.85 | 2.70 | 0.70 | 865 |
| 26 | 22 | 4.46 | 2.59 | 0.58 | 792 | 4.31 | 2.50 | 0.58 | 842 | 4.20 | 2.44 | 0.58 | 865 | 4.03 | 2.33 | 0.58 | 901 |
| 26 | 24 | 4.69 | 2.16 | 0.46 | 828 | 4.52 | 2.08 | 0.46 | 874 | 4.41 | 2.03 | 0.46 | 901 | 4.27 | 1.96 | 0.46 | 946 |
| 26 | 26 | 4.83 | 1.64 | 0.34 | 874 | 4.69 | 1.59 | 0.34 | 919 | 4.62 | 1.57 | 0.34 | 946 | 4.48 | 1.52 | 0.34 | 974 |
| 27 | 18 | 4.11 | 3.54 | 0.86 | 728 | 3.94 | 3.39 | 0.86 | 764 | 3.78 | 3.25 | 0.86 | 801 | 3.64 | 3.13 | 0.86 | 837 |
| 27 | 20 | 4.29 | 3.17 | 0.74 | 764 | 4.11 | 3.04 | 0.74 | 810 | 3.99 | 2.95 | 0.74 | 828 | 3.85 | 2.85 | 0.74 | 865 |
| 27 | 22 | 4.46 | 2.77 | 0.62 | 792 | 4.31 | 2.67 | 0.62 | 842 | 4.20 | 2.60 | 0.62 | 865 | 4.03 | 2.50 | 0.62 | 901 |
| 27 | 24 | 4.69 | 2.35 | 0.50 | 828 | 4.52 | 2.26 | 0.50 | 874 | 4.41 | 2.21 | 0.50 | 901 | 4.27 | 2.14 | 0.50 | 946 |
| 27 | 26 | 4.83 | 1.84 | 0.38 | 874 | 4.69 | 1.78 | 0.38 | 919 | 4.62 | 1.76 | 0.38 | 946 | 4.48 | 1.70 | 0.38 | 974 |
| 28 | 18 | 4.11 | 3.70 | 0.90 | 728 | 3.94 | 3.54 | 0.90 | 764 | 3.78 | 3.40 | 0.90 | 801 | 3.64 | 3.28 | 0.90 | 837 |
| 28 | 20 | 4.29 | 3.34 | 0.78 | 764 | 4.11 | 3.21 | 0.78 | 810 | 3.99 | 3.11 | 0.78 | 828 | 3.85 | 3.00 | 0.78 | 865 |
| 28 | 22 | 4.46 | 2.95 | 0.66 | 792 | 4.31 | 2.84 | 0.66 | 842 | 4.20 | 2.77 | 0.66 | 865 | 4.03 | 2.66 | 0.66 | 901 |
| 28 | 24 | 4.69 | 2.53 | 0.54 | 828 | 4.52 | 2.44 | 0.54 | 874 | 4.41 | 2.38 | 0.54 | 901 | 4.27 | 2.31 | 0.54 | 946 |
| 28 | 26 | 4.83 | 2.03 | 0.42 | 874 | 4.69 | 1.97 | 0.42 | 919 | 4.62 | 1.94 | 0.42 | 946 | 4.48 | 1.88 | 0.42 | 974 |
| 29 | 18 | 4.11 | 3.87 | 0.94 | 728 | 3.94 | 3.70 | 0.94 | 764 | 3.78 | 3.55 | 0.94 | 801 | 3.64 | 3.42 | 0.94 | 837 |
| 29 | 20 | 4.29 | 3.52 | 0.82 | 764 | 4.11 | 3.37 | 0.82 | 810 | 3.99 | 3.27 | 0.82 | 828 | 3.85 | 3.16 | 0.82 | 865 |
| 29 | 22 | 4.46 | 3.12 | 0.70 | 792 | 4.31 | 3.01 | 0.70 | 842 | 4.20 | 2.94 | 0.70 | 865 | 4.03 | 2.82 | 0.70 | 901 |
| 29 | 24 | 4.69 | 2.72 | 0.58 | 828 | 4.52 | 2.62 | 0.58 | 874 | 4.41 | 2.56 | 0.58 | 901 | 4.27 | 2.48 | 0.58 | 946 |
| 29 | 26 | 4.83 | 2.22 | 0.46 | 874 | 4.69 | 2.16 | 0.46 | 919 | 4.62 | 2.13 | 0.46 | 946 | 4.48 | 2.06 | 0.46 | 974 |
| 30 | 18 | 4.11 | 4.03 | 0.98 | 728 | 3.94 | 3.86 | 0.98 | 764 | 3.78 | 3.70 | 0.98 | 801 | 3.64 | 3.57 | 0.98 | 837 |
| 30 | 20 | 4.29 | 3.69 | 0.86 | 764 | 4.11 | 3.54 | 0.86 | 810 | 3.99 | 3.43 | 0.86 | 828 | 3.85 | 3.31 | 0.86 | 865 |
| 30 | 22 | 4.46 | 3.30 | 0.74 | 792 | 4.31 | 3.19 | 0.74 | 842 | 4.20 | 3.11 | 0.74 | 865 | 4.03 | 2.98 | 0.74 | 901 |
| 30 | 24 | 4.69 | 2.91 | 0.62 | 828 | 4.52 | 2.80 | 0.62 | 874 | 4.41 | 2.73 | 0.62 | 901 | 4.27 | 2.65 | 0.62 | 946 |
| 30 | 26 | 4.83 | 2.42 | 0.50 | 874 | 4.69 | 2.35 | 0.50 | 919 | 4.62 | 2.31 | 0.50 | 946 | 4.48 | 2.24 | 0.50 | 974 |
| 31 | 18 | 4.11 | 4.11 | 1.00 | 728 | 3.94 | 3.94 | 1.00 | 764 | 3.78 | 3.78 | 1.00 | 801 | 3.64 | 3.64 | 1.00 | 837 |
| 31 | 20 | 4.29 | 3.86 | 0.90 | 764 | 4.11 | 3.70 | 0.90 | 810 | 3.99 | 3.59 | 0.90 | 828 | 3.85 | 3.47 | 0.90 | 865 |
| 31 | 22 | 4.46 | 3.48 | 0.78 | 792 | 4.31 | 3.36 | 0.78 | 842 | 4.20 | 3.28 | 0.78 | 865 | 4.03 | 3.14 | 0.78 | 901 |
| 31 | 24 | 4.69 | 3.10 | 0.66 | 828 | 4.52 | 2.98 | 0.66 | 874 | 4.41 | 2.91 | 0.66 | 901 | 4.27 | 2.82 | 0.66 | 946 |
| 31 | 26 | 4.83 | 2.61 | 0.54 | 874 | 4.69 | 2.53 | 0.54 | 919 | 4.62 | 2.49 | 0.54 | 946 | 4.48 | 2.42 | 0.54 | 974 |
| 32 | 18 | 4.11 | 4.11 | 1.00 | 728 | 3.94 | 3.94 | 1.00 | 764 | 3.78 | 3.78 | 1.00 | 801 | 3.64 | 3.64 | 1.00 | 837 |
| 32 | 20 | 4.29 | 4.03 | 0.94 | 764 | 4.11 | 3.87 | 0.94 | 810 | 3.99 | 3.75 | 0.94 | 828 | 3.85 | 3.62 | 0.94 | 865 |
| 32 | 22 | 4.46 | 3.66 | 0.82 | 792 | 4.31 | 3.53 | 0.82 | 842 | 4.20 | 3.44 | 0.82 | 865 | 4.03 | 3.30 | 0.82 | 901 |
| 32 | 24 | 4.69 | 3.28 | 0.70 | 828 | 4.52 | 3.16 | 0.70 | 874 | 4.41 | 3.09 | 0.70 | 901 | 4.27 | 2.99 | 0.70 | 946 |
| 32 | 26 | 4.83 | 2.80 | 0.58 | 874 | 4.69 | 2.72 | 0.58 | 919 | 4.62 | 2.68 | 0.58 | 946 | 4.48 | 2.60 | 0.58 | 974 |

NOTE Q : Total capacity (kW) SHF : Sensible heat factor DB : Dry-bulb temperature
 SHC : Sensible heat capacity (kW) INPUT : Total power input (W) WB : Wet-bulb temperature

PERFORMANCE DATA COOL operation at Rated frequency

MUZ-FT35VGHZ

CAPACITY: 3.5 kW

SHF: 0.8

INPUT: 910 W

| INDOOR DB (°C) | INDOOR WB (°C) | OUTDOOR DB (°C) | | | | | | | | | | | |
|----------------|----------------|-----------------|------|------|-------|------|------|------|-------|------|------|------|-------|
| | | 35 | | | | 40 | | | | 46 | | | |
| | | Q | SHC | SHF | INPUT | Q | SHC | SHF | INPUT | Q | SHC | SHF | INPUT |
| 21 | 18 | 3.43 | 2.13 | 0.62 | 892 | 3.15 | 1.95 | 0.62 | 946 | 2.91 | 1.80 | 0.62 | 983 |
| 21 | 20 | 3.61 | 1.80 | 0.50 | 928 | 3.36 | 1.68 | 0.50 | 974 | 3.12 | 1.56 | 0.50 | 1028 |
| 22 | 18 | 3.43 | 2.26 | 0.66 | 892 | 3.15 | 2.08 | 0.66 | 946 | 2.91 | 1.92 | 0.66 | 983 |
| 22 | 20 | 3.61 | 1.95 | 0.54 | 928 | 3.36 | 1.81 | 0.54 | 974 | 3.12 | 1.68 | 0.54 | 1028 |
| 22 | 22 | 3.82 | 1.60 | 0.42 | 965 | 3.57 | 1.50 | 0.42 | 1019 | 3.33 | 1.40 | 0.42 | 1056 |
| 23 | 18 | 3.43 | 2.40 | 0.70 | 892 | 3.15 | 2.21 | 0.70 | 946 | 2.91 | 2.03 | 0.70 | 983 |
| 23 | 20 | 3.61 | 2.09 | 0.58 | 928 | 3.36 | 1.95 | 0.58 | 974 | 3.12 | 1.81 | 0.58 | 1028 |
| 23 | 22 | 3.82 | 1.75 | 0.46 | 965 | 3.57 | 1.64 | 0.46 | 1019 | 3.33 | 1.53 | 0.46 | 1056 |
| 24 | 18 | 3.43 | 2.54 | 0.74 | 892 | 3.15 | 2.33 | 0.74 | 946 | 2.91 | 2.15 | 0.74 | 983 |
| 24 | 20 | 3.61 | 2.24 | 0.62 | 928 | 3.36 | 2.08 | 0.62 | 974 | 3.12 | 1.93 | 0.62 | 1028 |
| 24 | 22 | 3.82 | 1.91 | 0.50 | 965 | 3.57 | 1.79 | 0.50 | 1019 | 3.33 | 1.66 | 0.50 | 1056 |
| 24 | 24 | 4.03 | 1.53 | 0.38 | 1001 | 3.78 | 1.44 | 0.38 | 1047 | 3.57 | 1.36 | 0.38 | 1092 |
| 25 | 18 | 3.43 | 2.68 | 0.78 | 892 | 3.15 | 2.46 | 0.78 | 946 | 2.91 | 2.27 | 0.78 | 983 |
| 25 | 20 | 3.61 | 2.38 | 0.66 | 928 | 3.36 | 2.22 | 0.66 | 974 | 3.12 | 2.06 | 0.66 | 1028 |
| 25 | 22 | 3.82 | 2.06 | 0.54 | 965 | 3.57 | 1.93 | 0.54 | 1019 | 3.33 | 1.80 | 0.54 | 1056 |
| 25 | 24 | 4.03 | 1.69 | 0.42 | 1001 | 3.78 | 1.59 | 0.42 | 1047 | 3.57 | 1.50 | 0.42 | 1092 |
| 26 | 18 | 3.43 | 2.81 | 0.82 | 892 | 3.15 | 2.58 | 0.82 | 946 | 2.91 | 2.38 | 0.82 | 983 |
| 26 | 20 | 3.61 | 2.52 | 0.70 | 928 | 3.36 | 2.35 | 0.70 | 974 | 3.12 | 2.18 | 0.70 | 1028 |
| 26 | 22 | 3.82 | 2.21 | 0.58 | 965 | 3.57 | 2.07 | 0.58 | 1019 | 3.33 | 1.93 | 0.58 | 1056 |
| 26 | 24 | 4.03 | 1.85 | 0.46 | 1001 | 3.78 | 1.74 | 0.46 | 1047 | 3.57 | 1.64 | 0.46 | 1092 |
| 26 | 26 | 4.24 | 1.44 | 0.34 | 1037 | 3.99 | 1.36 | 0.34 | 1083 | 3.75 | 1.27 | 0.34 | 1128 |
| 27 | 18 | 3.43 | 2.95 | 0.86 | 892 | 3.15 | 2.71 | 0.86 | 946 | 2.91 | 2.50 | 0.86 | 983 |
| 27 | 20 | 3.61 | 2.67 | 0.74 | 928 | 3.36 | 2.49 | 0.74 | 974 | 3.12 | 2.31 | 0.74 | 1028 |
| 27 | 22 | 3.82 | 2.37 | 0.62 | 965 | 3.57 | 2.21 | 0.62 | 1019 | 3.33 | 2.06 | 0.62 | 1056 |
| 27 | 24 | 4.03 | 2.01 | 0.50 | 1001 | 3.78 | 1.89 | 0.50 | 1047 | 3.57 | 1.79 | 0.50 | 1092 |
| 27 | 26 | 4.24 | 1.61 | 0.38 | 1037 | 3.99 | 1.52 | 0.38 | 1083 | 3.75 | 1.42 | 0.38 | 1128 |
| 28 | 18 | 3.43 | 3.09 | 0.90 | 892 | 3.15 | 2.84 | 0.90 | 946 | 2.91 | 2.61 | 0.90 | 983 |
| 28 | 20 | 3.61 | 2.81 | 0.78 | 928 | 3.36 | 2.62 | 0.78 | 974 | 3.12 | 2.43 | 0.78 | 1028 |
| 28 | 22 | 3.82 | 2.52 | 0.66 | 965 | 3.57 | 2.36 | 0.66 | 1019 | 3.33 | 2.19 | 0.66 | 1056 |
| 28 | 24 | 4.03 | 2.17 | 0.54 | 1001 | 3.78 | 2.04 | 0.54 | 1047 | 3.57 | 1.93 | 0.54 | 1092 |
| 28 | 26 | 4.24 | 1.78 | 0.42 | 1037 | 3.99 | 1.68 | 0.42 | 1083 | 3.75 | 1.57 | 0.42 | 1128 |
| 29 | 18 | 3.43 | 3.22 | 0.94 | 892 | 3.15 | 2.96 | 0.94 | 946 | 2.91 | 2.73 | 0.94 | 983 |
| 29 | 20 | 3.61 | 2.96 | 0.82 | 928 | 3.36 | 2.76 | 0.82 | 974 | 3.12 | 2.55 | 0.82 | 1028 |
| 29 | 22 | 3.82 | 2.67 | 0.70 | 965 | 3.57 | 2.50 | 0.70 | 1019 | 3.33 | 2.33 | 0.70 | 1056 |
| 29 | 24 | 4.03 | 2.33 | 0.58 | 1001 | 3.78 | 2.19 | 0.58 | 1047 | 3.57 | 2.07 | 0.58 | 1092 |
| 29 | 26 | 4.24 | 1.95 | 0.46 | 1037 | 3.99 | 1.84 | 0.46 | 1083 | 3.75 | 1.72 | 0.46 | 1128 |
| 30 | 18 | 3.43 | 3.36 | 0.98 | 892 | 3.15 | 3.09 | 0.98 | 946 | 2.91 | 2.85 | 0.98 | 983 |
| 30 | 20 | 3.61 | 3.10 | 0.86 | 928 | 3.36 | 2.89 | 0.86 | 974 | 3.12 | 2.68 | 0.86 | 1028 |
| 30 | 22 | 3.82 | 2.82 | 0.74 | 965 | 3.57 | 2.64 | 0.74 | 1019 | 3.33 | 2.46 | 0.74 | 1056 |
| 30 | 24 | 4.03 | 2.50 | 0.62 | 1001 | 3.78 | 2.34 | 0.62 | 1047 | 3.57 | 2.21 | 0.62 | 1092 |
| 30 | 26 | 4.24 | 2.12 | 0.50 | 1037 | 3.99 | 2.00 | 0.50 | 1083 | 3.75 | 1.87 | 0.50 | 1128 |
| 31 | 18 | 3.43 | 3.43 | 1.00 | 892 | 3.15 | 3.15 | 1.00 | 946 | 2.91 | 2.91 | 1.00 | 983 |
| 31 | 20 | 3.61 | 3.24 | 0.90 | 928 | 3.36 | 3.02 | 0.90 | 974 | 3.12 | 2.80 | 0.90 | 1028 |
| 31 | 22 | 3.82 | 2.98 | 0.78 | 965 | 3.57 | 2.78 | 0.78 | 1019 | 3.33 | 2.59 | 0.78 | 1056 |
| 31 | 24 | 4.03 | 2.66 | 0.66 | 1001 | 3.78 | 2.49 | 0.66 | 1047 | 3.57 | 2.36 | 0.66 | 1092 |
| 31 | 26 | 4.24 | 2.29 | 0.54 | 1037 | 3.99 | 2.15 | 0.54 | 1083 | 3.75 | 2.02 | 0.54 | 1128 |
| 32 | 18 | 3.43 | 3.43 | 1.00 | 892 | 3.15 | 3.15 | 1.00 | 946 | 2.91 | 2.91 | 1.00 | 983 |
| 32 | 20 | 3.61 | 3.39 | 0.94 | 928 | 3.36 | 3.16 | 0.94 | 974 | 3.12 | 2.93 | 0.94 | 1028 |
| 32 | 22 | 3.82 | 3.13 | 0.82 | 965 | 3.57 | 2.93 | 0.82 | 1019 | 3.33 | 2.73 | 0.82 | 1056 |
| 32 | 24 | 4.03 | 2.82 | 0.70 | 1001 | 3.78 | 2.65 | 0.70 | 1047 | 3.57 | 2.50 | 0.70 | 1092 |
| 32 | 26 | 4.24 | 2.46 | 0.58 | 1037 | 3.99 | 2.31 | 0.58 | 1083 | 3.75 | 2.17 | 0.58 | 1128 |

NOTE Q : Total capacity (kW) SHF : Sensible heat factor DB : Dry-bulb temperature
 SHC : Sensible heat capacity (kW) INPUT : Total power input (W) WB : Wet-bulb temperature

PERFORMANCE DATA COOL operation at Rated frequency

MUZ-FT50VGHZ

CAPACITY: 5.0 kW

SHF: 0.69

INPUT: 1630 W

| INDOOR DB (°C) | INDOOR WB (°C) | OUTDOOR DB (°C) | | | | | | | | | | | | | | | |
|----------------|----------------|-----------------|------|------|-------|------|------|------|-------|------|------|------|-------|------|------|------|-------|
| | | 21 | | | | 25 | | | | 27 | | | | 30 | | | |
| | | Q | SHC | SHF | INPUT | Q | SHC | SHF | INPUT | Q | SHC | SHF | INPUT | Q | SHC | SHF | INPUT |
| 21 | 18 | 5.88 | 3.00 | 0.51 | 1304 | 5.63 | 2.87 | 0.51 | 1369 | 5.40 | 2.75 | 0.51 | 1434 | 5.20 | 2.65 | 0.51 | 1500 |
| 21 | 20 | 6.13 | 2.39 | 0.39 | 1369 | 5.88 | 2.29 | 0.39 | 1451 | 5.70 | 2.22 | 0.39 | 1483 | 5.50 | 2.15 | 0.39 | 1549 |
| 22 | 18 | 5.88 | 3.23 | 0.55 | 1304 | 5.63 | 3.09 | 0.55 | 1369 | 5.40 | 2.97 | 0.55 | 1434 | 5.20 | 2.86 | 0.55 | 1500 |
| 22 | 20 | 6.13 | 2.63 | 0.43 | 1369 | 5.88 | 2.53 | 0.43 | 1451 | 5.70 | 2.45 | 0.43 | 1483 | 5.50 | 2.37 | 0.43 | 1549 |
| 22 | 22 | 6.38 | 1.98 | 0.31 | 1418 | 6.15 | 1.91 | 0.31 | 1508 | 6.00 | 1.86 | 0.31 | 1549 | 5.75 | 1.78 | 0.31 | 1614 |
| 23 | 18 | 5.88 | 3.47 | 0.59 | 1304 | 5.63 | 3.32 | 0.59 | 1369 | 5.40 | 3.19 | 0.59 | 1434 | 5.20 | 3.07 | 0.59 | 1500 |
| 23 | 20 | 6.13 | 2.88 | 0.47 | 1369 | 5.88 | 2.76 | 0.47 | 1451 | 5.70 | 2.68 | 0.47 | 1483 | 5.50 | 2.59 | 0.47 | 1549 |
| 23 | 22 | 6.38 | 2.23 | 0.35 | 1418 | 6.15 | 2.15 | 0.35 | 1508 | 6.00 | 2.10 | 0.35 | 1549 | 5.75 | 2.01 | 0.35 | 1614 |
| 24 | 18 | 5.88 | 3.70 | 0.63 | 1304 | 5.63 | 3.54 | 0.63 | 1369 | 5.40 | 3.40 | 0.63 | 1434 | 5.20 | 3.28 | 0.63 | 1500 |
| 24 | 20 | 6.13 | 3.12 | 0.51 | 1369 | 5.88 | 3.00 | 0.51 | 1451 | 5.70 | 2.91 | 0.51 | 1483 | 5.50 | 2.81 | 0.51 | 1549 |
| 24 | 22 | 6.38 | 2.49 | 0.39 | 1418 | 6.15 | 2.40 | 0.39 | 1508 | 6.00 | 2.34 | 0.39 | 1549 | 5.75 | 2.24 | 0.39 | 1614 |
| 24 | 24 | 6.70 | 1.81 | 0.27 | 1483 | 6.45 | 1.74 | 0.27 | 1565 | 6.30 | 1.70 | 0.27 | 1614 | 6.10 | 1.65 | 0.27 | 1695 |
| 25 | 18 | 5.88 | 3.94 | 0.67 | 1304 | 5.63 | 3.77 | 0.67 | 1369 | 5.40 | 3.62 | 0.67 | 1434 | 5.20 | 3.48 | 0.67 | 1500 |
| 25 | 20 | 6.13 | 3.37 | 0.55 | 1369 | 5.88 | 3.23 | 0.55 | 1451 | 5.70 | 3.14 | 0.55 | 1483 | 5.50 | 3.03 | 0.55 | 1549 |
| 25 | 22 | 6.38 | 2.74 | 0.43 | 1418 | 6.15 | 2.64 | 0.43 | 1508 | 6.00 | 2.58 | 0.43 | 1549 | 5.75 | 2.47 | 0.43 | 1614 |
| 25 | 24 | 6.70 | 2.08 | 0.31 | 1483 | 6.45 | 2.00 | 0.31 | 1565 | 6.30 | 1.95 | 0.31 | 1614 | 6.10 | 1.89 | 0.31 | 1695 |
| 26 | 18 | 5.88 | 4.17 | 0.71 | 1304 | 5.63 | 3.99 | 0.71 | 1369 | 5.40 | 3.83 | 0.71 | 1434 | 5.20 | 3.69 | 0.71 | 1500 |
| 26 | 20 | 6.13 | 3.61 | 0.59 | 1369 | 5.88 | 3.47 | 0.59 | 1451 | 5.70 | 3.36 | 0.59 | 1483 | 5.50 | 3.25 | 0.59 | 1549 |
| 26 | 22 | 6.38 | 3.00 | 0.47 | 1418 | 6.15 | 2.89 | 0.47 | 1508 | 6.00 | 2.82 | 0.47 | 1549 | 5.75 | 2.70 | 0.47 | 1614 |
| 26 | 24 | 6.70 | 2.35 | 0.35 | 1483 | 6.45 | 2.26 | 0.35 | 1565 | 6.30 | 2.21 | 0.35 | 1614 | 6.10 | 2.14 | 0.35 | 1695 |
| 26 | 26 | 6.90 | 1.59 | 0.23 | 1565 | 6.70 | 1.54 | 0.23 | 1646 | 6.60 | 1.52 | 0.23 | 1695 | 6.40 | 1.47 | 0.23 | 1744 |
| 27 | 18 | 5.88 | 4.41 | 0.75 | 1304 | 5.63 | 4.22 | 0.75 | 1369 | 5.40 | 4.05 | 0.75 | 1434 | 5.20 | 3.90 | 0.75 | 1500 |
| 27 | 20 | 6.13 | 3.86 | 0.63 | 1369 | 5.88 | 3.70 | 0.63 | 1451 | 5.70 | 3.59 | 0.63 | 1483 | 5.50 | 3.47 | 0.63 | 1549 |
| 27 | 22 | 6.38 | 3.25 | 0.51 | 1418 | 6.15 | 3.14 | 0.51 | 1508 | 6.00 | 3.06 | 0.51 | 1549 | 5.75 | 2.93 | 0.51 | 1614 |
| 27 | 24 | 6.70 | 2.61 | 0.39 | 1483 | 6.45 | 2.52 | 0.39 | 1565 | 6.30 | 2.46 | 0.39 | 1614 | 6.10 | 2.38 | 0.39 | 1695 |
| 27 | 26 | 6.90 | 1.86 | 0.27 | 1565 | 6.70 | 1.81 | 0.27 | 1646 | 6.60 | 1.78 | 0.27 | 1695 | 6.40 | 1.73 | 0.27 | 1744 |
| 28 | 18 | 5.88 | 4.64 | 0.79 | 1304 | 5.63 | 4.44 | 0.79 | 1369 | 5.40 | 4.27 | 0.79 | 1434 | 5.20 | 4.11 | 0.79 | 1500 |
| 28 | 20 | 6.13 | 4.10 | 0.67 | 1369 | 5.88 | 3.94 | 0.67 | 1451 | 5.70 | 3.82 | 0.67 | 1483 | 5.50 | 3.69 | 0.67 | 1549 |
| 28 | 22 | 6.38 | 3.51 | 0.55 | 1418 | 6.15 | 3.38 | 0.55 | 1508 | 6.00 | 3.30 | 0.55 | 1549 | 5.75 | 3.16 | 0.55 | 1614 |
| 28 | 24 | 6.70 | 2.88 | 0.43 | 1483 | 6.45 | 2.77 | 0.43 | 1565 | 6.30 | 2.71 | 0.43 | 1614 | 6.10 | 2.62 | 0.43 | 1695 |
| 28 | 26 | 6.90 | 2.14 | 0.31 | 1565 | 6.70 | 2.08 | 0.31 | 1646 | 6.60 | 2.05 | 0.31 | 1695 | 6.40 | 1.98 | 0.31 | 1744 |
| 29 | 18 | 5.88 | 4.88 | 0.83 | 1304 | 5.63 | 4.67 | 0.83 | 1369 | 5.40 | 4.48 | 0.83 | 1434 | 5.20 | 4.32 | 0.83 | 1500 |
| 29 | 20 | 6.13 | 4.35 | 0.71 | 1369 | 5.88 | 4.17 | 0.71 | 1451 | 5.70 | 4.05 | 0.71 | 1483 | 5.50 | 3.91 | 0.71 | 1549 |
| 29 | 22 | 6.38 | 3.76 | 0.59 | 1418 | 6.15 | 3.63 | 0.59 | 1508 | 6.00 | 3.54 | 0.59 | 1549 | 5.75 | 3.39 | 0.59 | 1614 |
| 29 | 24 | 6.70 | 3.15 | 0.47 | 1483 | 6.45 | 3.03 | 0.47 | 1565 | 6.30 | 2.96 | 0.47 | 1614 | 6.10 | 2.87 | 0.47 | 1695 |
| 29 | 26 | 6.90 | 2.42 | 0.35 | 1565 | 6.70 | 2.35 | 0.35 | 1646 | 6.60 | 2.31 | 0.35 | 1695 | 6.40 | 2.24 | 0.35 | 1744 |
| 30 | 18 | 5.88 | 5.11 | 0.87 | 1304 | 5.63 | 4.89 | 0.87 | 1369 | 5.40 | 4.70 | 0.87 | 1434 | 5.20 | 4.52 | 0.87 | 1500 |
| 30 | 20 | 6.13 | 4.59 | 0.75 | 1369 | 5.88 | 4.41 | 0.75 | 1451 | 5.70 | 4.28 | 0.75 | 1483 | 5.50 | 4.13 | 0.75 | 1549 |
| 30 | 22 | 6.38 | 4.02 | 0.63 | 1418 | 6.15 | 3.87 | 0.63 | 1508 | 6.00 | 3.78 | 0.63 | 1549 | 5.75 | 3.62 | 0.63 | 1614 |
| 30 | 24 | 6.70 | 3.42 | 0.51 | 1483 | 6.45 | 3.29 | 0.51 | 1565 | 6.30 | 3.21 | 0.51 | 1614 | 6.10 | 3.11 | 0.51 | 1695 |
| 30 | 26 | 6.90 | 2.69 | 0.39 | 1565 | 6.70 | 2.61 | 0.39 | 1646 | 6.60 | 2.57 | 0.39 | 1695 | 6.40 | 2.50 | 0.39 | 1744 |
| 31 | 18 | 5.88 | 5.35 | 0.91 | 1304 | 5.63 | 5.12 | 0.91 | 1369 | 5.40 | 4.91 | 0.91 | 1434 | 5.20 | 4.73 | 0.91 | 1500 |
| 31 | 20 | 6.13 | 4.84 | 0.79 | 1369 | 5.88 | 4.64 | 0.79 | 1451 | 5.70 | 4.50 | 0.79 | 1483 | 5.50 | 4.35 | 0.79 | 1549 |
| 31 | 22 | 6.38 | 4.27 | 0.67 | 1418 | 6.15 | 4.12 | 0.67 | 1508 | 6.00 | 4.02 | 0.67 | 1549 | 5.75 | 3.85 | 0.67 | 1614 |
| 31 | 24 | 6.70 | 3.69 | 0.55 | 1483 | 6.45 | 3.55 | 0.55 | 1565 | 6.30 | 3.47 | 0.55 | 1614 | 6.10 | 3.36 | 0.55 | 1695 |
| 31 | 26 | 6.90 | 2.97 | 0.43 | 1565 | 6.70 | 2.88 | 0.43 | 1646 | 6.60 | 2.84 | 0.43 | 1695 | 6.40 | 2.75 | 0.43 | 1744 |
| 32 | 18 | 5.88 | 5.58 | 0.95 | 1304 | 5.63 | 5.34 | 0.95 | 1369 | 5.40 | 5.13 | 0.95 | 1434 | 5.20 | 4.94 | 0.95 | 1500 |
| 32 | 20 | 6.13 | 5.08 | 0.83 | 1369 | 5.88 | 4.88 | 0.83 | 1451 | 5.70 | 4.73 | 0.83 | 1483 | 5.50 | 4.57 | 0.83 | 1549 |
| 32 | 22 | 6.38 | 4.53 | 0.71 | 1418 | 6.15 | 4.37 | 0.71 | 1508 | 6.00 | 4.26 | 0.71 | 1549 | 5.75 | 4.08 | 0.71 | 1614 |
| 32 | 24 | 6.70 | 3.95 | 0.59 | 1483 | 6.45 | 3.81 | 0.59 | 1565 | 6.30 | 3.72 | 0.59 | 1614 | 6.10 | 3.60 | 0.59 | 1695 |
| 32 | 26 | 6.90 | 3.24 | 0.47 | 1565 | 6.70 | 3.15 | 0.47 | 1646 | 6.60 | 3.10 | 0.47 | 1695 | 6.40 | 3.01 | 0.47 | 1744 |

NOTE Q : Total capacity (kW) SHF : Sensible heat factor DB : Dry-bulb temperature
 SHC : Sensible heat capacity (kW) INPUT : Total power input (W) WB : Wet-bulb temperature

PERFORMANCE DATA COOL operation at Rated frequency

MUZ-FT50VGHZ

CAPACITY: 5.0 kW

SHF: 0.69

INPUT: 1630 W

| INDOOR DB (°C) | INDOOR WB (°C) | OUTDOOR DB (°C) | | | | | | | | | | | |
|----------------|----------------|-----------------|------|------|-------|------|------|------|-------|------|------|------|-------|
| | | 35 | | | | 40 | | | | 46 | | | |
| | | Q | SHC | SHF | INPUT | Q | SHC | SHF | INPUT | Q | SHC | SHF | INPUT |
| 21 | 18 | 4.90 | 2.50 | 0.51 | 1597 | 4.50 | 2.30 | 0.51 | 1695 | 4.15 | 2.12 | 0.51 | 1760 |
| 21 | 20 | 5.15 | 2.01 | 0.39 | 1663 | 4.80 | 1.87 | 0.39 | 1744 | 4.45 | 1.74 | 0.39 | 1842 |
| 22 | 18 | 4.90 | 2.70 | 0.55 | 1597 | 4.50 | 2.48 | 0.55 | 1695 | 4.15 | 2.28 | 0.55 | 1760 |
| 22 | 20 | 5.15 | 2.21 | 0.43 | 1663 | 4.80 | 2.06 | 0.43 | 1744 | 4.45 | 1.91 | 0.43 | 1842 |
| 22 | 22 | 5.45 | 1.69 | 0.31 | 1728 | 5.10 | 1.58 | 0.31 | 1826 | 4.75 | 1.47 | 0.31 | 1891 |
| 23 | 18 | 4.90 | 2.89 | 0.59 | 1597 | 4.50 | 2.66 | 0.59 | 1695 | 4.15 | 2.45 | 0.59 | 1760 |
| 23 | 20 | 5.15 | 2.42 | 0.47 | 1663 | 4.80 | 2.26 | 0.47 | 1744 | 4.45 | 2.09 | 0.47 | 1842 |
| 23 | 22 | 5.45 | 1.91 | 0.35 | 1728 | 5.10 | 1.79 | 0.35 | 1826 | 4.75 | 1.66 | 0.35 | 1891 |
| 24 | 18 | 4.90 | 3.09 | 0.63 | 1597 | 4.50 | 2.84 | 0.63 | 1695 | 4.15 | 2.61 | 0.63 | 1760 |
| 24 | 20 | 5.15 | 2.63 | 0.51 | 1663 | 4.80 | 2.45 | 0.51 | 1744 | 4.45 | 2.27 | 0.51 | 1842 |
| 24 | 22 | 5.45 | 2.13 | 0.39 | 1728 | 5.10 | 1.99 | 0.39 | 1826 | 4.75 | 1.85 | 0.39 | 1891 |
| 24 | 24 | 5.75 | 1.55 | 0.27 | 1793 | 5.40 | 1.46 | 0.27 | 1875 | 5.10 | 1.38 | 0.27 | 1956 |
| 25 | 18 | 4.90 | 3.28 | 0.67 | 1597 | 4.50 | 3.02 | 0.67 | 1695 | 4.15 | 2.78 | 0.67 | 1760 |
| 25 | 20 | 5.15 | 2.83 | 0.55 | 1663 | 4.80 | 2.64 | 0.55 | 1744 | 4.45 | 2.45 | 0.55 | 1842 |
| 25 | 22 | 5.45 | 2.34 | 0.43 | 1728 | 5.10 | 2.19 | 0.43 | 1826 | 4.75 | 2.04 | 0.43 | 1891 |
| 25 | 24 | 5.75 | 1.78 | 0.31 | 1793 | 5.40 | 1.67 | 0.31 | 1875 | 5.10 | 1.58 | 0.31 | 1956 |
| 26 | 18 | 4.90 | 3.48 | 0.71 | 1597 | 4.50 | 3.20 | 0.71 | 1695 | 4.15 | 2.95 | 0.71 | 1760 |
| 26 | 20 | 5.15 | 3.04 | 0.59 | 1663 | 4.80 | 2.83 | 0.59 | 1744 | 4.45 | 2.63 | 0.59 | 1842 |
| 26 | 22 | 5.45 | 2.56 | 0.47 | 1728 | 5.10 | 2.40 | 0.47 | 1826 | 4.75 | 2.23 | 0.47 | 1891 |
| 26 | 24 | 5.75 | 2.01 | 0.35 | 1793 | 5.40 | 1.89 | 0.35 | 1875 | 5.10 | 1.79 | 0.35 | 1956 |
| 26 | 26 | 6.05 | 1.39 | 0.23 | 1858 | 5.70 | 1.31 | 0.23 | 1940 | 5.35 | 1.23 | 0.23 | 2021 |
| 27 | 18 | 4.90 | 3.68 | 0.75 | 1597 | 4.50 | 3.38 | 0.75 | 1695 | 4.15 | 3.11 | 0.75 | 1760 |
| 27 | 20 | 5.15 | 3.24 | 0.63 | 1663 | 4.80 | 3.02 | 0.63 | 1744 | 4.45 | 2.80 | 0.63 | 1842 |
| 27 | 22 | 5.45 | 2.78 | 0.51 | 1728 | 5.10 | 2.60 | 0.51 | 1826 | 4.75 | 2.42 | 0.51 | 1891 |
| 27 | 24 | 5.75 | 2.24 | 0.39 | 1793 | 5.40 | 2.11 | 0.39 | 1875 | 5.10 | 1.99 | 0.39 | 1956 |
| 27 | 26 | 6.05 | 1.63 | 0.27 | 1858 | 5.70 | 1.54 | 0.27 | 1940 | 5.35 | 1.44 | 0.27 | 2021 |
| 28 | 18 | 4.90 | 3.87 | 0.79 | 1597 | 4.50 | 3.56 | 0.79 | 1695 | 4.15 | 3.28 | 0.79 | 1760 |
| 28 | 20 | 5.15 | 3.45 | 0.67 | 1663 | 4.80 | 3.22 | 0.67 | 1744 | 4.45 | 2.98 | 0.67 | 1842 |
| 28 | 22 | 5.45 | 3.00 | 0.55 | 1728 | 5.10 | 2.81 | 0.55 | 1826 | 4.75 | 2.61 | 0.55 | 1891 |
| 28 | 24 | 5.75 | 2.47 | 0.43 | 1793 | 5.40 | 2.32 | 0.43 | 1875 | 5.10 | 2.19 | 0.43 | 1956 |
| 28 | 26 | 6.05 | 1.88 | 0.31 | 1858 | 5.70 | 1.77 | 0.31 | 1940 | 5.35 | 1.66 | 0.31 | 2021 |
| 29 | 18 | 4.90 | 4.07 | 0.83 | 1597 | 4.50 | 3.74 | 0.83 | 1695 | 4.15 | 3.44 | 0.83 | 1760 |
| 29 | 20 | 5.15 | 3.66 | 0.71 | 1663 | 4.80 | 3.41 | 0.71 | 1744 | 4.45 | 3.16 | 0.71 | 1842 |
| 29 | 22 | 5.45 | 3.22 | 0.59 | 1728 | 5.10 | 3.01 | 0.59 | 1826 | 4.75 | 2.80 | 0.59 | 1891 |
| 29 | 24 | 5.75 | 2.70 | 0.47 | 1793 | 5.40 | 2.54 | 0.47 | 1875 | 5.10 | 2.40 | 0.47 | 1956 |
| 29 | 26 | 6.05 | 2.12 | 0.35 | 1858 | 5.70 | 2.00 | 0.35 | 1940 | 5.35 | 1.87 | 0.35 | 2021 |
| 30 | 18 | 4.90 | 4.26 | 0.87 | 1597 | 4.50 | 3.92 | 0.87 | 1695 | 4.15 | 3.61 | 0.87 | 1760 |
| 30 | 20 | 5.15 | 3.86 | 0.75 | 1663 | 4.80 | 3.60 | 0.75 | 1744 | 4.45 | 3.34 | 0.75 | 1842 |
| 30 | 22 | 5.45 | 3.43 | 0.63 | 1728 | 5.10 | 3.21 | 0.63 | 1826 | 4.75 | 2.99 | 0.63 | 1891 |
| 30 | 24 | 5.75 | 2.93 | 0.51 | 1793 | 5.40 | 2.75 | 0.51 | 1875 | 5.10 | 2.60 | 0.51 | 1956 |
| 30 | 26 | 6.05 | 2.36 | 0.39 | 1858 | 5.70 | 2.22 | 0.39 | 1940 | 5.35 | 2.09 | 0.39 | 2021 |
| 31 | 18 | 4.90 | 4.46 | 0.91 | 1597 | 4.50 | 4.10 | 0.91 | 1695 | 4.15 | 3.78 | 0.91 | 1760 |
| 31 | 20 | 5.15 | 4.07 | 0.79 | 1663 | 4.80 | 3.79 | 0.79 | 1744 | 4.45 | 3.52 | 0.79 | 1842 |
| 31 | 22 | 5.45 | 3.65 | 0.67 | 1728 | 5.10 | 3.42 | 0.67 | 1826 | 4.75 | 3.18 | 0.67 | 1891 |
| 31 | 24 | 5.75 | 3.16 | 0.55 | 1793 | 5.40 | 2.97 | 0.55 | 1875 | 5.10 | 2.81 | 0.55 | 1956 |
| 31 | 26 | 6.05 | 2.60 | 0.43 | 1858 | 5.70 | 2.45 | 0.43 | 1940 | 5.35 | 2.30 | 0.43 | 2021 |
| 32 | 18 | 4.90 | 4.66 | 0.95 | 1597 | 4.50 | 4.28 | 0.95 | 1695 | 4.15 | 3.94 | 0.95 | 1760 |
| 32 | 20 | 5.15 | 4.27 | 0.83 | 1663 | 4.80 | 3.98 | 0.83 | 1744 | 4.45 | 3.69 | 0.83 | 1842 |
| 32 | 22 | 5.45 | 3.87 | 0.71 | 1728 | 5.10 | 3.62 | 0.71 | 1826 | 4.75 | 3.37 | 0.71 | 1891 |
| 32 | 24 | 5.75 | 3.39 | 0.59 | 1793 | 5.40 | 3.19 | 0.59 | 1875 | 5.10 | 3.01 | 0.59 | 1956 |
| 32 | 26 | 6.05 | 2.84 | 0.47 | 1858 | 5.70 | 2.68 | 0.47 | 1940 | 5.35 | 2.51 | 0.47 | 2021 |

NOTE Q : Total capacity (kW) SHF : Sensible heat factor DB : Dry-bulb temperature
 SHC : Sensible heat capacity (kW) INPUT : Total power input (W) WB : Wet-bulb temperature

PERFORMANCE DATA HEAT operation at Rated frequency
MUZ-FT25VGHZ

CAPACITY: 3.2 kW INPUT: 760 W

| INDOOR DB (°C) | OUTDOOR WB (°C) | | | | | | | | | | | | | | | | | | | |
|----------------|-----------------|-------|------|-------|------|-------|------|-------|------|-------|------|-------|------|-------|------|-------|------|-------|------|-------|
| | -25 | | -20 | | -15 | | -10 | | -5 | | 0 | | 5 | | 10 | | 15 | | 20 | |
| | Q | INPUT | Q | INPUT | Q | INPUT | Q | INPUT | Q | INPUT | Q | INPUT | Q | INPUT | Q | INPUT | Q | INPUT | Q | INPUT |
| 15 | 0.80 | 205 | 1.22 | 304 | 1.60 | 395 | 2.02 | 494 | 2.43 | 593 | 2.85 | 669 | 3.26 | 722 | 3.68 | 768 | 4.06 | 790 | 4.48 | 806 |
| 21 | 0.74 | 220 | 1.12 | 319 | 1.50 | 418 | 1.92 | 532 | 2.30 | 631 | 2.72 | 699 | 3.10 | 752 | 3.52 | 790 | 3.90 | 813 | 4.30 | 844 |
| 26 | 0.51 | 243 | 0.90 | 342 | 1.31 | 456 | 1.73 | 570 | 2.14 | 669 | 2.53 | 737 | 2.94 | 790 | 3.36 | 828 | 3.74 | 851 | 4.16 | 874 |

MUZ-FT35VGHZ

CAPACITY: 4.0 kW INPUT: 1020 W

| INDOOR DB (°C) | OUTDOOR WB (°C) | | | | | | | | | | | | | | | | | | | |
|----------------|-----------------|-------|------|-------|------|-------|------|-------|------|-------|------|-------|------|-------|------|-------|------|-------|------|-------|
| | -25 | | -20 | | -15 | | -10 | | -5 | | 0 | | 5 | | 10 | | 15 | | 20 | |
| | Q | INPUT | Q | INPUT | Q | INPUT | Q | INPUT | Q | INPUT | Q | INPUT | Q | INPUT | Q | INPUT | Q | INPUT | Q | INPUT |
| 15 | 1.00 | 275 | 1.52 | 408 | 2.00 | 530 | 2.52 | 663 | 3.04 | 796 | 3.56 | 898 | 4.08 | 969 | 4.60 | 1030 | 5.08 | 1061 | 5.60 | 1081 |
| 21 | 0.92 | 296 | 1.40 | 428 | 1.88 | 561 | 2.40 | 714 | 2.88 | 847 | 3.40 | 938 | 3.88 | 1010 | 4.40 | 1061 | 4.88 | 1091 | 5.38 | 1132 |
| 26 | 0.64 | 326 | 1.12 | 459 | 1.64 | 612 | 2.16 | 765 | 2.68 | 898 | 3.16 | 989 | 3.68 | 1061 | 4.20 | 1112 | 4.68 | 1142 | 5.20 | 1173 |

MUZ-FT50VGHZ

CAPACITY: 5.0 kW INPUT: 1300 W

| INDOOR DB (°C) | OUTDOOR WB (°C) | | | | | | | | | | | | | | | | | | | |
|----------------|-----------------|-------|------|-------|------|-------|------|-------|------|-------|------|-------|------|-------|------|-------|------|-------|------|-------|
| | -25 | | -20 | | -15 | | -10 | | -5 | | 0 | | 5 | | 10 | | 15 | | 20 | |
| | Q | INPUT | Q | INPUT | Q | INPUT | Q | INPUT | Q | INPUT | Q | INPUT | Q | INPUT | Q | INPUT | Q | INPUT | Q | INPUT |
| 15 | 1.25 | 351 | 1.90 | 520 | 2.50 | 676 | 3.15 | 845 | 3.80 | 1014 | 4.45 | 1144 | 5.10 | 1235 | 5.75 | 1313 | 6.35 | 1352 | 7.00 | 1378 |
| 21 | 1.15 | 377 | 1.75 | 546 | 2.35 | 715 | 3.00 | 910 | 3.60 | 1079 | 4.25 | 1196 | 4.85 | 1287 | 5.50 | 1352 | 6.10 | 1391 | 6.73 | 1443 |
| 26 | 0.80 | 416 | 1.40 | 585 | 2.05 | 780 | 2.70 | 975 | 3.35 | 1144 | 3.95 | 1261 | 4.60 | 1352 | 5.25 | 1417 | 5.85 | 1456 | 6.50 | 1495 |

NOTE: Q: Total capacity (kW) INPUT : Total power input (W) DB: Dry-bulb temperature WB: Wet-bulb temperature

10 ACTUATOR CONTROL

MUZ-FT25VGHZ MUZ-FT35VGHZ MUZ-FT50VGHZ

10-1. OUTDOOR FAN MOTOR CONTROL

The fan motor turns ON/OFF, interlocking with the compressor.
 [ON] The fan motor turns ON 5 seconds before the compressor starts up.
 [OFF] The fan motor turns OFF 15 seconds after the compressor has stopped running.

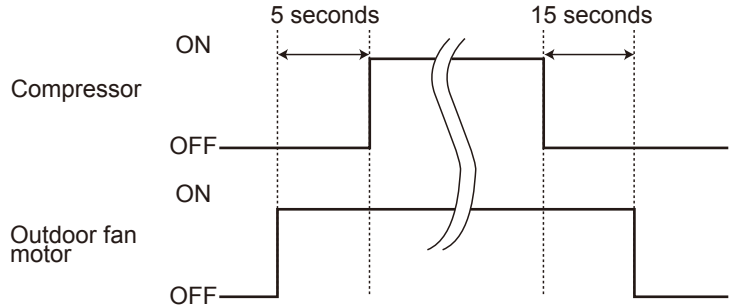

10-2. R.V. COIL CONTROL

- Heating ON
- Cooling OFF
- Dry OFF

NOTE: The 4-way valve reverses for 5 seconds right before startup of the compressor.

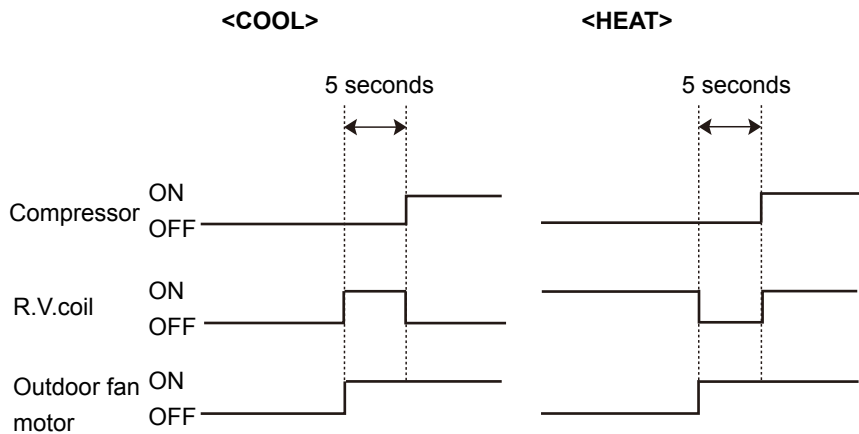

10-3. RELATION BETWEEN MAIN SENSOR AND ACTUATOR

| Sensor | Purpose | Actuator | | | | |
|---|--|------------|-----|-------------------|-----------|------------------|
| | | Compressor | LEV | Outdoor fan motor | R.V. coil | Indoor fan motor |
| Discharge temperature thermistor | Protection | ○ | ○ | | | |
| Indoor coil temperature thermistor | Cooling: Coil frost prevention | ○ | | | | |
| | Heating: High pressure protection | ○ | ○ | | | |
| Defrost thermistor | Heating: Defrosting | ○ | ○ | ○ | ○ | ○ |
| Fin temperature thermistor | Protection | ○ | | ○ | | |
| Ambient temperature thermistor | Cooling: Low ambient temperature operation | ○ | ○ | ○ | | |
| Outdoor heat exchanger temperature thermistor | Cooling: Low ambient temperature operation | ○ | ○ | ○ | | |
| | Cooling: High pressure protection | ○ | ○ | ○ | | |

MUZ-FT25VGHZ MUZ-FT35VGHZ MUZ-FT50VGHZ**11-1. CHANGE IN DEFROST SETTING****Changing defrost finish temperature**

<JS> To change the defrost finish temperature, cut/solder the JS wire of the outdoor inverter P.C. board.
(Refer to 12-6.1)

| Jumper wire | | Defrost finish temperature (°C) | |
|-------------|----------------------------|---------------------------------|--------------|
| | | MUZ-FT25/35VGHZ | MUZ-FT50VGHZ |
| JS | Soldered (Initial setting) | 5 | 10 |
| | None (Cut) | 10 | 18 |

11-2. PRE-HEAT CONTROL SETTING**PRE-HEAT CONTROL**

When moisture gets into the refrigerant cycle, it may interfere the startup of the compressor at low outside temperature. The pre-heat control prevents this interference. The pre-heat control turns ON when the discharge temperature thermistor is 20°C or below. When the pre-heat control turns ON, the compressor is energized. (About 50 W)

Pre-heat control setting

<JK>

ON: To activate the pre-heat control, cut the JK wire of the inverter P.C. board.

OFF: To deactivate the pre-heat control, solder the JK wire of the inverter P.C. board.

(Refer to 12-6.1)

NOTE: When the inverter P.C. board is replaced, check the jumper wires, and cut/solder them if necessary.

MUZ-FT25VGHZ MUZ-FT35VGHZ MUZ-FT50VGHZ**12-1. CAUTIONS ON TROUBLESHOOTING****1. Before troubleshooting, check the following**

- 1) Check the power supply voltage.
- 2) Check the indoor/outdoor connecting wire for miswiring.

2. Take care of the following during servicing

- 1) Before servicing the air conditioner, be sure to turn OFF the main unit first with the remote controller, and then after confirming the horizontal vane is closed, turn OFF the breaker and/or disconnect the power plug.
- 2) Be sure to turn OFF the power supply before removing the front panel, the cabinet, the top panel, and the electronic control P.C. board.
- 3) When removing the electrical parts, be careful of the residual voltage of smoothing capacitor.
- 4) When removing the electronic control P.C. board, hold the edge of the board with care NOT to apply stress on the components.
- 5) When connecting or disconnecting the connectors, hold the connector housing. DO NOT pull the lead wires.

<Incorrect>

**Lead wiring**

<Correct>

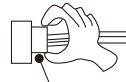
**Connector housing****3. Troubleshooting procedure**

- 1) Check if the OPERATION INDICATOR lamp on the indoor unit is blinking on and off to indicate an abnormality.
To make sure, check how many times the OPERATION INDICATOR lamp is blinking on and off before starting service work.
- 2) Before servicing, check that the connector and terminal are connected properly.
- 3) When the electronic control P.C. board seems to be defective, check the copper foil pattern for disconnection and the components for bursting and discoloration.
- 4) Refer to 12-2 and 12-3.

12-2. FAILURE MODE RECALL FUNCTION

Outline of the function

This air conditioner can memorize the abnormal condition which has occurred once.

Even though LED indication listed on the troubleshooting check table (12-3.) disappears, the memorized failure details can be recalled.

1. Flow chart of failure mode recall function for the indoor/outdoor unit

FT25/35/50VG - [E1]
 FT25/35/50VGK - [E1], [ET1] FT25/35/50VGK - [SC1]

Operational procedure

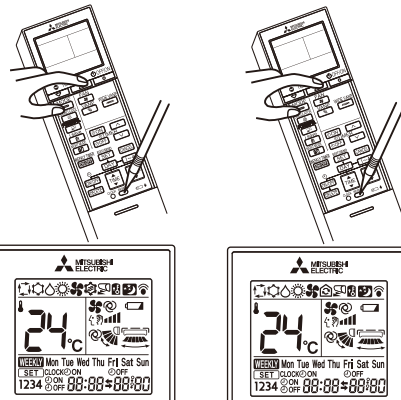
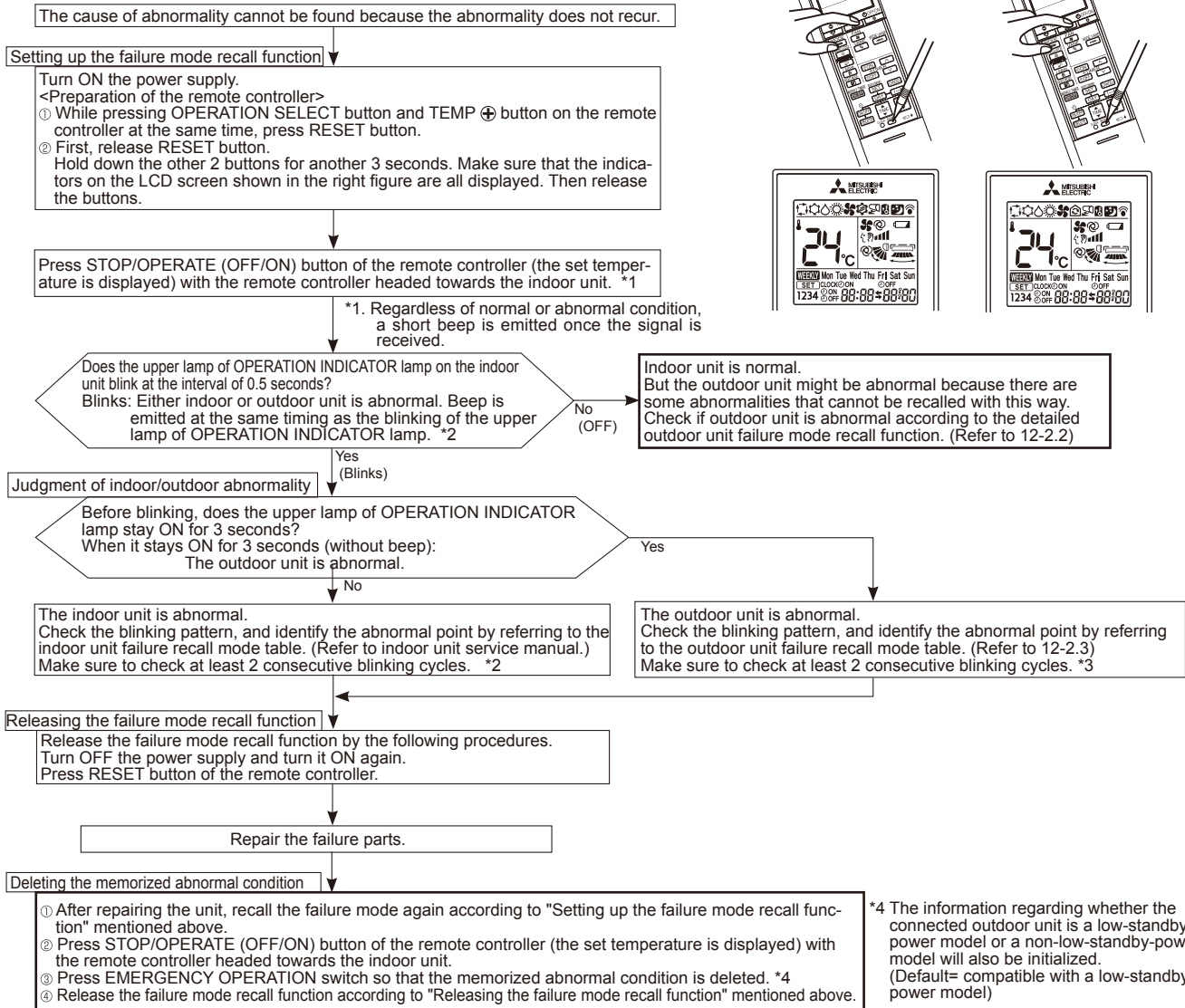

NOTE: 1. Make sure to release the failure mode recall function after it is set up, otherwise the unit cannot operate properly.
 2. If the abnormal condition is not deleted from the memory, the last abnormal condition is kept memorized.

*2. Blinking pattern when the indoor unit is abnormal:

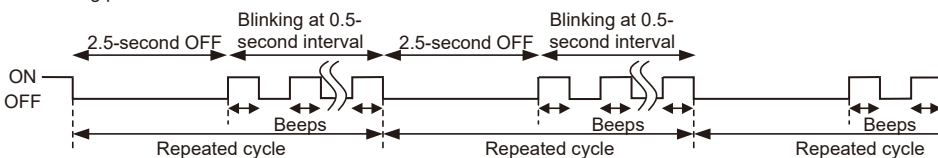

*3. Blinking pattern when the outdoor unit is abnormal:

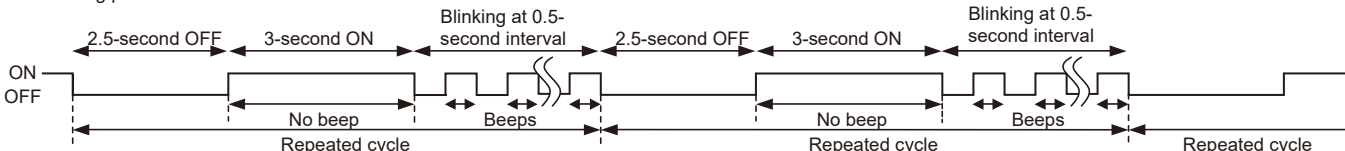

2. Flow chart of the detailed outdoor unit failure mode recall function

Operational procedure

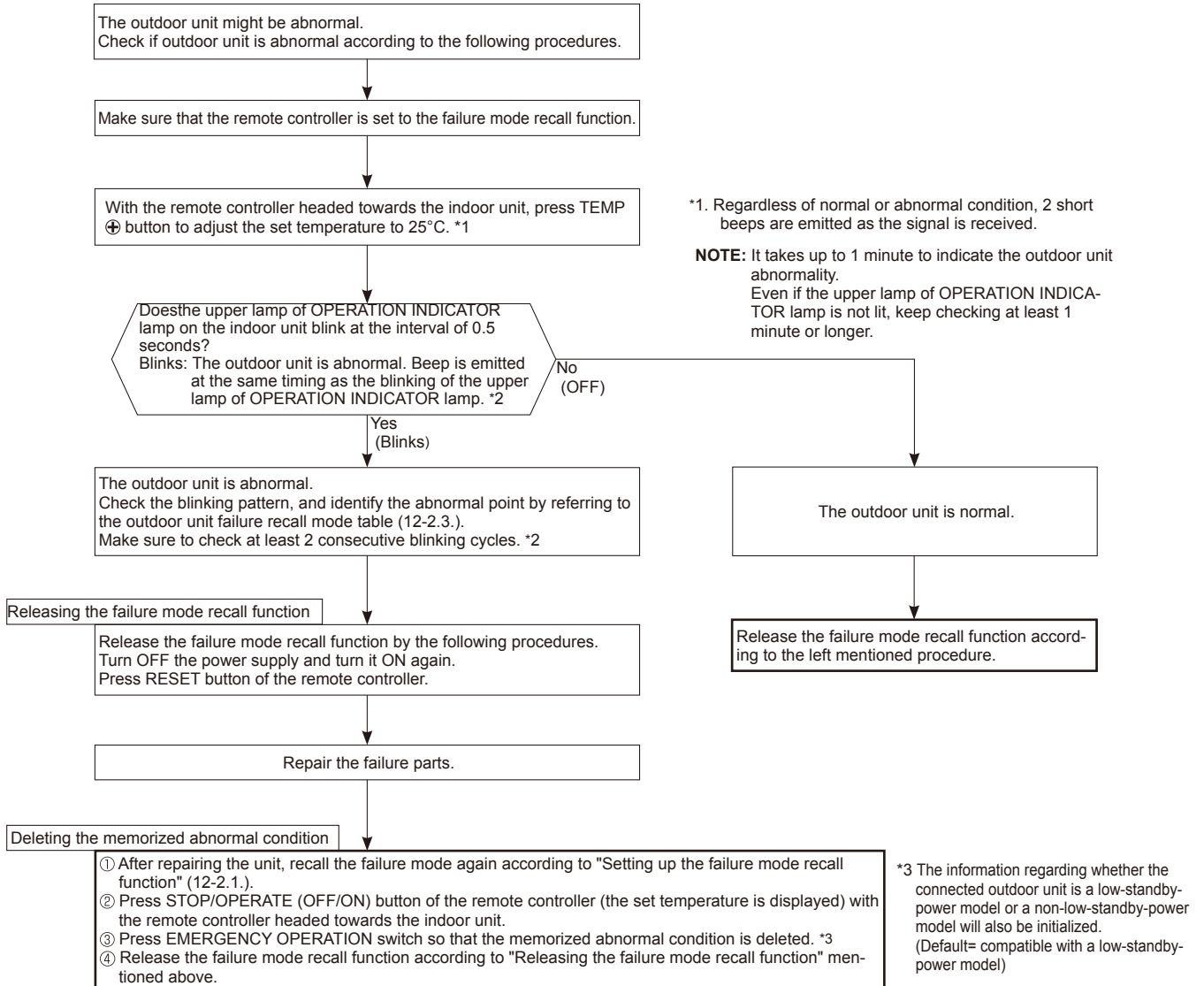

NOTE: 1. Make sure to release the failure mode recall function after it is set up, otherwise the unit cannot operate properly.
2. If the abnormal condition is not deleted from the memory, the last abnormal condition is kept memorized.

*2 Blinking pattern when outdoor unit is abnormal:

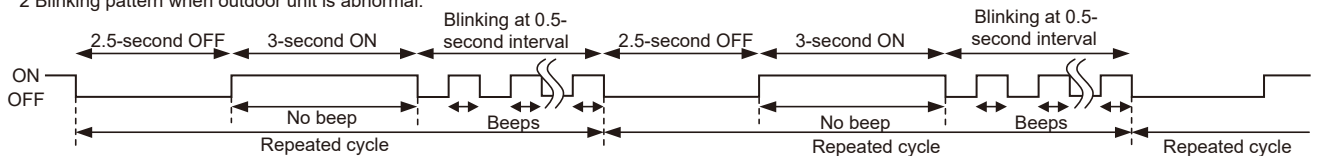

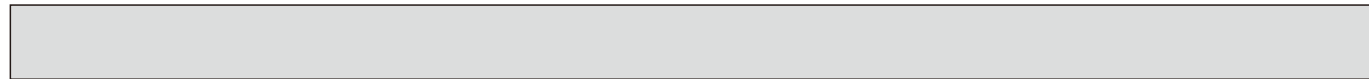

3. Outdoor unit failure recall mode table

NOTE: Blinking patterns of this mode differ from the ones of TROUBLESHOOTING CHECK TABLE (12-3.).

| Upper lamp of OPERATION INDICATOR lamp (Indoor unit) | Abnormal point (Failure mode/protection) | LED indication (Outdoor P.C. board) | Condition | Remedy | Indoor/outdoor unit failure mode recall function | Outdoor unit failure mode recall function |
|--|--|-------------------------------------|---|---|--|---|
| OFF | None (Normal) | — | — | — | — | — |
| 1-time blink 2.5 seconds OFF | Indoor/outdoor communication, receiving error | — | Any signals from the inverter P.C. board cannot be received normally for 3 minutes. | •Refer to 12-5. ㉔ How to check miswiring and serial signal error. | ○ | ○ |
| | Indoor/outdoor communication, receiving error | — | Although the inverter P.C. board sends signal "0", signal "1" has been received 30 consecutive times. | •Refer to 12-5. ㉔ How to check miswiring and serial signal error. | | |
| 2-time blink 2.5 seconds OFF | Outdoor power system | — | Overcurrent protection cut-out operates 3 consecutive times within 1 minute after the compressor gets started. | •Reconnect connectors. •Refer to 12-5. ㉔ How to check inverter/compressor". •Check stop valve. | ○ | ○ |
| 3-time blink 2.5 seconds OFF | Discharge temperature thermistor | 1-time blink every 2.5 seconds | Thermistor shorts or opens during compressor running. | •Refer to 12-5. ㉔ "Check of outdoor thermistors". Defective outdoor thermistors can be identified by checking the blinking pattern of LED. | ○ | ○ |
| | Defrost thermistor | — | | | | |
| | Fin temperature thermistor | 3-time blink 2.5 seconds OFF | | | | |
| | P.C. board temperature thermistor | 4-time blink 2.5 seconds OFF | | | | |
| | Ambient temperature thermistor | 2-time blink 2.5 seconds OFF | | | | |
| | Outdoor heat exchanger temperature thermistor | — | | | | |
| 4-time blink 2.5 seconds OFF | Overcurrent | 11-time blink 2.5 seconds OFF | Large current flows into power module (IC700). | •Reconnect compressor connector. •Refer to 12-5. ㉔ How to check inverter/compressor". •Check stop valve. | — | ○ |
| | Compressor synchronous abnormality (Compressor startup failure protection) | 12-time blink 2.5 seconds OFF | Waveform of compressor current is distorted. | •Reconnect compressor connector. •Refer to 12-5. ㉔ How to check inverter/compressor". | — | ○ |
| 5-time blink 2.5 seconds OFF | Discharge temperature | — | Temperature of discharge temperature thermistor exceeds 116°C, compressor stops. Compressor can restart if discharge temperature thermistor reads 100°C or less 3 minutes later. | •Check refrigerant circuit and refrigerant amount. •Refer to 12-5. ㉔ Check of LEV". | — | ○ |
| 6-time blink 2.5 seconds OFF | High pressure | — | Temperature of indoor coil thermistor exceeds 70°C in HEAT mode. Temperature of defrost thermistor exceeds 70°C in COOL mode. | •Check refrigerant circuit and refrigerant amount. •Check stop valve. | — | ○ |
| 7-time blink 2.5 seconds OFF | Fin temperature/P.C. board temperature | 7-time blink 2.5 seconds OFF | Temperature of fin temperature thermistor on the inverter P.C. board exceeds 75 ~ 86°C, or temperature of P.C. board temperature thermistor on the inverter P.C. board exceeds 72 ~ 85°C. | •Check around outdoor unit. •Check outdoor unit air passage. •Refer to 12-5. ㉔ Check of outdoor fan motor". | — | ○ |
| 8-time blink 2.5 seconds OFF | Outdoor fan motor | — | Outdoor fan has stopped 3 times in a row within 30 seconds after outdoor fan startup. | •Refer to 12-5. ㉔ Check of outdoor fan motor". Refer to 12-5. ㉔ Check of inverter P.C. board". | — | ○ |
| 9-time blink 2.5 seconds OFF | Nonvolatile memory data | 5-time blink 2.5 seconds OFF | Nonvolatile memory data cannot be read properly. | •Replace the inverter P.C. board. | ○ | ○ |
| | Power module (IC700) | 6-time blink 2.5 seconds OFF | The interface short circuit occurs in the output of the power module (IC700). The compressor winding shorts circuit. | •Refer to 12-5. ㉔ How to check inverter/compressor". | — | |

NOTE: Blinking patterns of this mode differ from the ones of TROUBLESHOOTING CHECK TABLE (12-3.).

| Upper lamp of OPERATION INDICATOR lamp (Indoor unit) | Abnormal point (Failure mode/protection) | LED indication (Outdoor P.C. board) | Condition | Remedy | Indoor/outdoor unit failure mode recall function | Outdoor unit failure mode recall function |
|--|--|-------------------------------------|---|---|--|---|
| 10-time blink 2.5 seconds OFF | Discharge temperature | — | Temperature of discharge temperature thermistor has been 50°C or less for 20 minutes. | <ul style="list-style-type: none"> Refer to 12-5. ㉔ "Check of LEV". Check refrigerant circuit and refrigerant amount. | — | ○ |
| 11-time blink 2.5 seconds OFF | Bus-bar voltage (DC) | 8-time blink 2.5 seconds OFF | Bus-bar voltage of inverter cannot be detected normally. | <ul style="list-style-type: none"> Refer to 12-5. ㉔ "How to check inverter/compressor". | — | ○ |
| | Each phase current of compressor | 9-time blink 2.5 seconds OFF | Each phase current of compressor cannot be detected normally. | | | |
| 14-time blink 2.5 seconds OFF | Stop valve (Closed valve) | 14-time blink 2.5 seconds OFF | Closed valve is detected by compressor current. | <ul style="list-style-type: none"> Check stop valve. | ○ | ○ |
| | 4-way valve/ Pipe temperature | 16-time blink 2.5 seconds OFF | The 4-way valve does not work properly. The indoor coil thermistor detects an abnormal temperature. | <ul style="list-style-type: none"> Check the 4-way valve. Replace the inverter P.C. board. | | |
| 16-time blink 2.5 seconds OFF | Outdoor refrigerant system abnormality | 1-time blink 2.5 seconds OFF | A closed valve and air trapped in the refrigerant circuit are detected based on the temperature sensed by the indoor and outdoor thermistors and the current of the compressor. | <ul style="list-style-type: none"> Check for a gas leak in a connecting piping etc. Check the stop valve. Refer to 12-5. ㉔ "Check of outdoor refrigerant circuit". | ○ | ○ |

12-3. TROUBLESHOOTING CHECK TABLE

| No. | Symptom | LED indication | Abnormal point/ Condition | Condition | Remedy |
|-----|--|------------------------------------|---|---|--|
| 1 | Outdoor unit does not operate. | 1-time blink every 2.5 seconds | Outdoor power system | Overcurrent protection cut-out operates 3 consecutive times within 1 minute after the compressor gets started. | <ul style="list-style-type: none"> •Reconnect connector of compressor. •Refer to 12-5.Ⓐ "How to check inverter/compressor". •Check stop valve. |
| 2 | | | Outdoor thermistors | Discharge temperature thermistor, fin temperature thermistor, defrost thermistor, P.C. board temperature thermistor, outdoor heat exchanger temperature thermistor or ambient temperature thermistor shorts or opens during compressor running. | •Refer to 12-5.Ⓒ "Check of outdoor thermistors". |
| 3 | | | Outdoor control system | Nonvolatile memory data cannot be read properly. (Upper lamp of OPERATION INDICATOR lamp of the indoor unit lights up or blinks 7-time.) | •Replace inverter P.C. board. |
| 4 | 'Outdoor unit stops and restarts 3 minutes later' is repeated. | 6-time blink 2.5 seconds OFF | Serial signal | The communication fails between the indoor and outdoor unit for 3 minutes. | •Refer to 12-5.Ⓜ "How to check miswiring and serial signal error. |
| 5 | | 11-time blink 2.5 seconds OFF | Stop valve/ Closed valve | Closed valve is detected by compressor current. | •Check stop valve. |
| 6 | | 14-time blink 2.5 seconds OFF | Outdoor unit (Other abnormality) | Outdoor unit is defective. | •Refer to 12-2.2. "Flow chart of the detailed outdoor unit failure mode recall function". |
| 7 | | 16-time blink 2.5 seconds OFF | 4-way valve/ Pipe temperature | The 4-way valve does not work properly. The indoor coil thermistor detects an abnormal temperature. | <ul style="list-style-type: none"> •Refer to 12-5.Ⓔ "Check of R.V. coil". •Replace the inverter P.C. board. |
| 8 | | 17-time blink 2.5 seconds OFF | Outdoor refrigerant system abnormality | A closed valve and air trapped in the refrigerant circuit are detected based on the temperature sensed by the indoor and outdoor thermistors and the current of the compressor. | <ul style="list-style-type: none"> •Check for a gas leak in a connecting piping etc. •Check the stop valve. •Refer to 12-5.Ⓢ "Check of outdoor refrigerant circuit". |
| 9 | | 2-time blink 2.5 seconds OFF | Overcurrent protection | Large current flows into power module (IC700). | <ul style="list-style-type: none"> •Reconnect connector of compressor. •Refer to 12-5.Ⓐ "How to check inverter/compressor". •Check stop valve. |
| 10 | | 3-time blink 2.5 seconds OFF | Discharge temperature overheat protection | Temperature of discharge temperature thermistor exceeds 116°C, compressor stops. Compressor can restart if discharge temperature thermistor reads 100°C or less 3 minutes later. | <ul style="list-style-type: none"> •Check refrigerant circuit and refrigerant amount. •Refer to 12-5.Ⓢ "Check of LEV". |
| 11 | | 4-time blink 2.5 seconds OFF | Fin temperature / P.C. board temperature thermistor overheat protection | Temperature of fin temperature thermistor on the heat sink exceeds 75 ~ 86°C or temperature of P.C. board temperature thermistor on the inverter P.C. board exceeds 72 ~ 85°C. | <ul style="list-style-type: none"> •Check around outdoor unit. •Check outdoor unit air passage. •Refer to 12-5.Ⓛ "Check of outdoor fan motor". |
| 12 | 5-time blink 2.5 seconds OFF | High pressure protection | Indoor coil thermistor exceeds 70°C in HEAT mode. Defrost thermistor exceeds 70°C in COOL mode. | <ul style="list-style-type: none"> •Check refrigerant circuit and refrigerant amount. •Check stop valve. | |
| 13 | 8-time blink 2.5 seconds OFF | Compressor synchronous abnormality | The waveform of compressor current is distorted. | <ul style="list-style-type: none"> •Reconnect connector of compressor. •Refer to 12-5.Ⓐ "How to check inverter/compressor". | |
| 14 | 10-time blink 2.5 seconds OFF | Outdoor fan motor | Outdoor fan has stopped 3 times in a row within 30 seconds after outdoor fan startup. | <ul style="list-style-type: none"> •Refer to 12-5.Ⓛ "Check of outdoor fan motor. •Refer to 12-5.Ⓛ "Check of inverter P.C. board. | |
| 15 | 12-time blink 2.5 seconds OFF | Each phase current of compressor | Each phase current of compressor cannot be detected normally. | •Refer to 12-5.Ⓐ "How to check inverter/compressor". | |
| 16 | 13-time blink 2.5 seconds OFF | Bus-bar voltage (DC) | Bus-bar voltage of inverter cannot be detected normally. | •Refer to 12-5.Ⓐ "How to check inverter/compressor". | |
| 17 | Outdoor unit operates. | 1-time blink 2.5 seconds OFF | Frequency drop by current protection | When the input current exceeds approximately 10A, compressor frequency lowers. | <ul style="list-style-type: none"> The unit is normal, but check the following. •Check if indoor filters are clogged. •Check if refrigerant is short. •Check if indoor/outdoor unit air circulation is short cycled. |
| 18 | | 3-time blink 2.5 seconds OFF | Frequency drop by high pressure protection | Temperature of indoor coil thermistor exceeds 55°C in HEAT mode, compressor frequency lowers. | |
| | | | Frequency drop by defrosting in COOL mode | Indoor coil thermistor reads 8°C or less in COOL mode, compressor frequency lowers. | |
| 19 | | 4-time blink 2.5 seconds OFF | Frequency drop by discharge temperature protection | Temperature of discharge temperature thermistor exceeds 111°C, compressor frequency lowers. | <ul style="list-style-type: none"> •Check refrigerant circuit and refrigerant amount. •Refer to 12-5.Ⓢ "Check of LEV". •Refer to 12-5.Ⓒ "Check of outdoor thermistors". |
| 20 | | 5-time blink 2.5 seconds OFF | Outside temperature thermistor protection | When the outside temperature thermistor shorts or opens, protective operation without that thermistor is performed. | •Refer to 12-5.Ⓒ Check of outdoor thermistors. |



| No. | Symptom | LED indication | Abnormal point/ Condition | Condition | Remedy |
|-----|------------------------|---------------------------------|---|---|---|
| 21 | Outdoor unit operates. | 7-time blink 2.5 seconds OFF | Low discharge temperature protection | Temperature of discharge temperature thermistor has been 50°C or less for 20 minutes. | <ul style="list-style-type: none"> Refer to 12-5 ⑧ "Check of LEV". Check refrigerant circuit and refrigerant amount. |
| 22 | | 8-time blink 2.5 seconds OFF | PAM protection PAM: Pulse Amplitude Modulation | The overcurrent flows into PFC (Power factor correction: IC820) or the bus-bar voltage reaches 394 V or more, PAM stops and restarts. | This is not malfunction. PAM protection will be activated in the following cases: 1 Instantaneous power voltage drop. (Short time power failure) 2 When the power supply voltage is high. |
| 23 | | 9-time blink 2.5 seconds OFF | Inverter check mode | The connector of compressor is disconnected, inverter check mode starts. | <ul style="list-style-type: none"> Check if the connector of the compressor is correctly connected. Refer to 12-5.④ "How to check inverter/compressor". |

NOTE: 1. The location of LED is illustrated at the right figure. Refer to 12-6.1.
 2. LED is lit during normal operation.

The blinking frequency shows the number of times the LED blinks after every 2.5-second OFF.
 (Example) When the blinking frequency is "2".

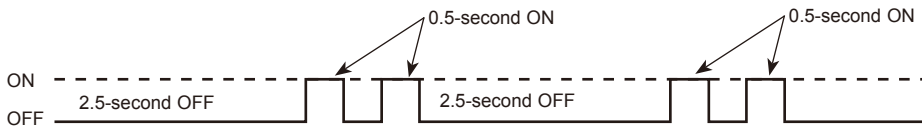

Inverter P.C. board

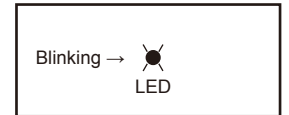

12-4. TROUBLE CRITERION OF MAIN PARTS
MUZ-FT25VGHZ MUZ-FT35VGHZ MUZ-FT50VGHZ

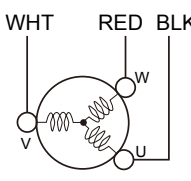
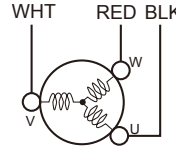
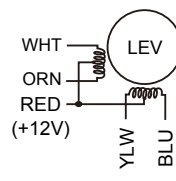
| Part name | Check method and criterion | Figure | | | | | | | | | | | | | |
|---|--|---|--------------|-----------------|-----------------|--------------|--------------|--------------|-------------------------------------|-------------|--------|--|-----|-----|--|
| Defrost thermistor (RT61) Fin temperature thermistor (RT64) Ambient temperature thermistor (RT65) Outdoor heat exchanger temperature thermistor (RT68) | Measure the resistance with a tester. Refer to 12-6. "Test point diagram and voltage", 1. "Inverter P.C. board", for the chart of thermistor. | | | | | | | | | | | | | | |
| Discharge temperature thermistor (RT62) | Measure the resistance with a tester. Before measurement, hold the thermistor with your hands to warm it up. Refer to 12-6. "Test point diagram and voltage", 1. "Inverter P.C. board", for the chart of thermistor. | | | | | | | | | | | | | | |
| Compressor | Measure the resistance between terminals using a tester. (Temperature: -10 to 40°C) |  | | | | | | | | | | | | | |
| | <table border="1"> <thead> <tr> <th rowspan="2"></th> <th colspan="3">Normal (Ω)</th> </tr> <tr> <th>MUZ-FT25VGHZ</th> <th>MUZ-FT35VGHZ</th> <th>MUZ-FT50VGHZ</th> </tr> </thead> <tbody> <tr> <td>U-V</td> <td colspan="3" rowspan="3">0.86 - 1.06</td> </tr> <tr> <td>U-W</td> </tr> <tr> <td>V-W</td> </tr> </tbody> </table> | | Normal (Ω) | | | MUZ-FT25VGHZ | MUZ-FT35VGHZ | MUZ-FT50VGHZ | U-V | 0.86 - 1.06 | | | U-W | V-W | |
| | Normal (Ω) | | | | | | | | | | | | | | |
| | MUZ-FT25VGHZ | MUZ-FT35VGHZ | MUZ-FT50VGHZ | | | | | | | | | | | | |
| U-V | 0.86 - 1.06 | | | | | | | | | | | | | | |
| U-W | | | | | | | | | | | | | | | |
| V-W | | | | | | | | | | | | | | | |
| Outdoor fan motor | Measure the resistance between lead wires using a tester. (Temperature: -10 ~ 40°C) |  | | | | | | | | | | | | | |
| | <table border="1"> <thead> <tr> <th rowspan="2">Color of lead wire</th> <th colspan="3">Normal (Ω)</th> </tr> <tr> <th>MUZ-FT25VGHZ</th> <th>MUZ-FT35VGHZ</th> <th>MUZ-FT50VGHZ</th> </tr> </thead> <tbody> <tr> <td>RED - BLK BLK - WHT WHT - RED</td> <td>33 - 40</td> <td colspan="2">8 - 10</td> </tr> </tbody> </table> | Color of lead wire | Normal (Ω) | | | MUZ-FT25VGHZ | MUZ-FT35VGHZ | MUZ-FT50VGHZ | RED - BLK BLK - WHT WHT - RED | 33 - 40 | 8 - 10 | | | | |
| Color of lead wire | Normal (Ω) | | | | | | | | | | | | | | |
| | MUZ-FT25VGHZ | MUZ-FT35VGHZ | MUZ-FT50VGHZ | | | | | | | | | | | | |
| RED - BLK BLK - WHT WHT - RED | 33 - 40 | 8 - 10 | | | | | | | | | | | | | |
| R.V. coil (21S4) | Measure the resistance using a tester. (Temperature: -10 to 40°C) | | | | | | | | | | | | | | |
| | <table border="1"> <thead> <tr> <th colspan="2">Normal (kΩ)</th> </tr> <tr> <th>MUZ-FT25VGHZ</th> <th>MUZ-FT35/50VGHZ</th> </tr> </thead> <tbody> <tr> <td>1.41 - 2.00</td> <td>1.17 - 1.66</td> </tr> </tbody> </table> | Normal (kΩ) | | MUZ-FT25VGHZ | MUZ-FT35/50VGHZ | 1.41 - 2.00 | 1.17 - 1.66 | | | | | | | | |
| Normal (kΩ) | | | | | | | | | | | | | | | |
| MUZ-FT25VGHZ | MUZ-FT35/50VGHZ | | | | | | | | | | | | | | |
| 1.41 - 2.00 | 1.17 - 1.66 | | | | | | | | | | | | | | |
| Expansion valve coil (LEV) | Measure the resistance using a tester. (Temperature: -10 to 40°C) |  | | | | | | | | | | | | | |
| Defrost heater | Measure the resistance using a tester. (Temperature: -10 to 40°C) | | | | | | | | | | | | | | |
| | <table border="1"> <thead> <tr> <th colspan="2">Normal (Ω)</th> </tr> <tr> <th>MUZ-FT25/35VGHZ</th> <th>MUZ-FT50VGHZ</th> </tr> </thead> <tbody> <tr> <td>778 - 951</td> <td>355 - 434</td> </tr> </tbody> </table> | Normal (Ω) | | MUZ-FT25/35VGHZ | MUZ-FT50VGHZ | 778 - 951 | 355 - 434 | | | | | | | | |
| Normal (Ω) | | | | | | | | | | | | | | | |
| MUZ-FT25/35VGHZ | MUZ-FT50VGHZ | | | | | | | | | | | | | | |
| 778 - 951 | 355 - 434 | | | | | | | | | | | | | | |

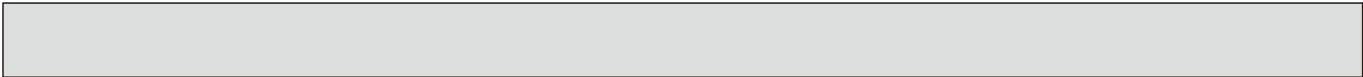

12-5. TROUBLESHOOTING FLOW

A How to check inverter/compressor

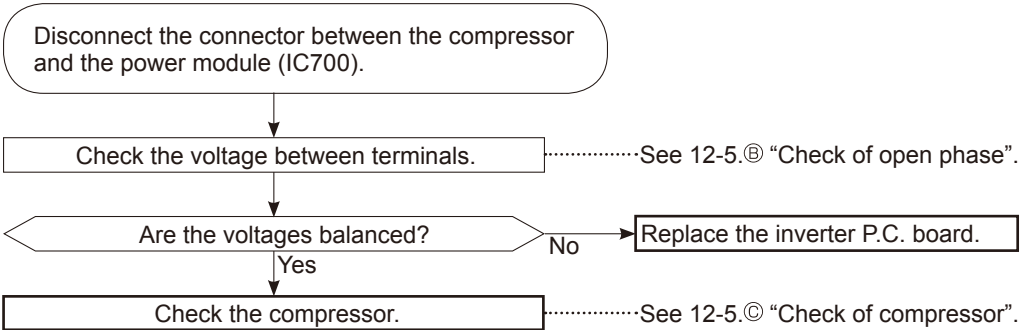

B Check of open phase

- With the connector between the compressor and the power module (IC700) disconnected, activate the inverter and check if the inverter is normal by measuring **the voltage balance** between the terminals.

Output voltage is 50 - 130V. (The voltage may differ according to the tester.)

<< Operation method >>

Start cooling or heating operation by pressing EMERGENCY OPERATION switch on the indoor unit. (TEST RUN OPERATION: Refer to 9-3.)

<< Measurement point >>

At 3 points

- BLK (U)-WHT (V) ※ Measure AC voltage between the lead wires at 3 points.
- BLK (U)-RED (W)
- WHT(V)-RED (W)

- NOTE:**
1. Output voltage varies according to power supply voltage.
 2. Measure the voltage by analog type tester.
 3. During this check, LED of the inverter P.C. board blinks 9 times. (Refer to 12-6.1.)

C Check of compressor

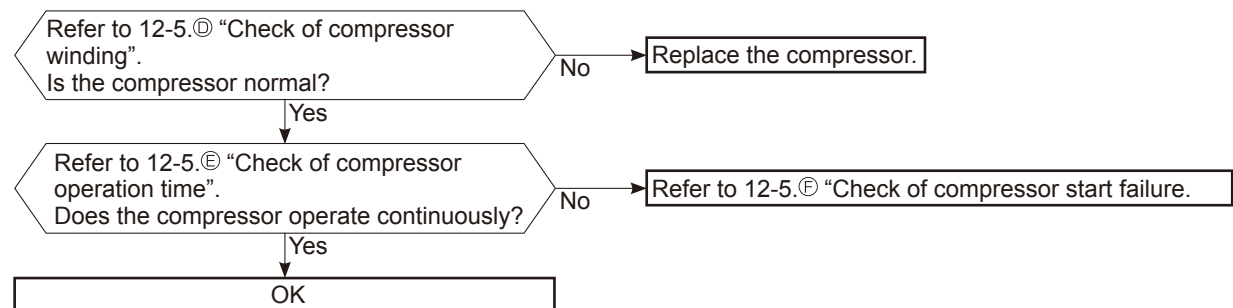

D Check of compressor winding

- Disconnect the connector between the compressor and the power module (IC700), and measure the resistance between the compressor terminals.

<<Measurement point>>

At 3 points

BLK-WHT

BLK-RED

WHT-RED

※ Measure the resistance between the lead wires at 3 points.

<<Judgement>>

Refer to 12-4.

0 [Ω]Abnormal [short]

Infinite [Ω]Abnormal [open]

NOTE: Be sure to zero the ohmmeter before measurement.

E Check of compressor operation time

- Connect the compressor and activate the inverter. Then measure the time until the inverter stops due to overcurrent.

<<Operation method>>

Start heating or cooling operation by pressing EMERGENCY OPERATION switch on the indoor unit. (Test run operation: Refer to 9-3.)

<<Measurement>>

Measure the time from the start of compressor to the stop of compressor due to overcurrent.

<<Judgement>>

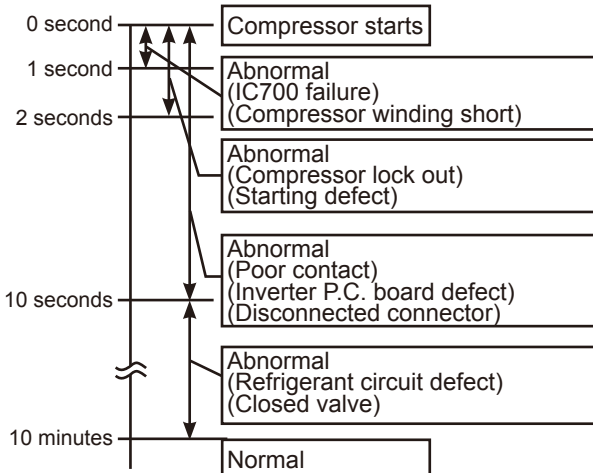

F Check of compressor start failure

Confirm that ①~④ is normal.

•Electrical circuit check

①. Contact of the compressor connector

②. Output voltage of inverter P.C. board and balance of them (See 12-5.⑥)

③. Direct current voltage between DB61(+) and (-) on the inverter P.C. board

④. Voltage between outdoor terminal block S1-S2

Does the compressor run for 10 seconds or more after it starts?

Yes

Check the refrigerant circuit.
Check the stop valve.

No

After the compressor is heated with a drier, does the compressor start? ※1

No

Replace the compressor.

Yes

Compressor start failure. Activate pre-heat control.
(Refer to 11-2. "PRE-HEAT CONTROL SETTING")

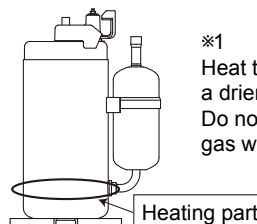

※1 Heat the compressor with a drier for about 20 minutes. Do not recover refrigerant gas while heating.

G Check of outdoor thermistors

Disconnect the connector of thermistor in the inverter P.C. board (see below table), and measure the resistance of thermistor.

Is the resistance of thermistor normal?
(Refer to 12-6.1.)

No

Replace the thermistor except RT64.
When RT64 is abnormal, replace the inverter P.C. board.

Yes

Reconnect the connector of thermistor.
Turn ON the power supply and press EMERGENCY OPERATION switch.

Does the unit operate for 10 minutes or more
without showing thermistor abnormality?

No

Replace the inverter P.C. board.

Yes

OK (Cause is poor contact.)

| Thermistor | Symbol | Connector, Pin No. | Board |
|------------------------------------|--------|-----------------------------|---------------------|
| Defrost | RT61 | Between CN641 pin1 and pin2 | Inverter P.C. board |
| Discharge temperature | RT62 | Between CN641 pin3 and pin4 | |
| Fin temperature | RT64 | Between CN642 pin1 and pin2 | |
| Ambient temperature | RT65 | Between CN643 pin1 and pin2 | |
| Outdoor heat exchanger temperature | RT68 | Between CN644 pin1 and pin3 | |

H Check of R.V. coil

- ※ First of all, measure the resistance of R.V. coil to check if the coil is defective. Refer to 12-4.
- ※ In case CN721 is disconnected or R.V. coil is open, voltage is generated between the terminal pins of the connector although no signal is being transmitted to R.V. coil.
Check if CN721 is connected.

Unit operates in COOL mode even if it is set to HEAT mode.

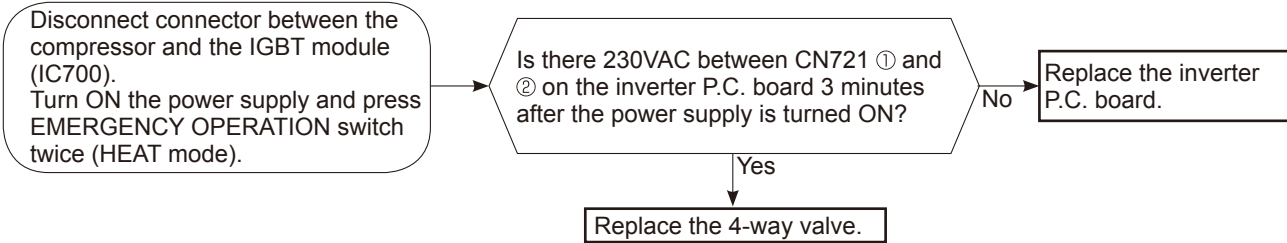

Unit operates in HEAT mode even if it is set to COOL mode.

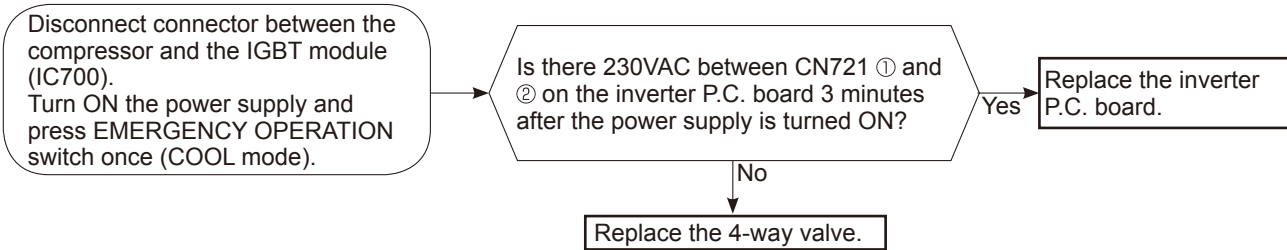

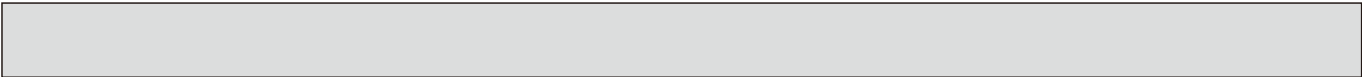

① Check of outdoor fan motor

Disconnect the connectors CN931 and CN932 from the inverter P.C. board.
Check the connection between the connector CN931 and CN932.

Is the resistance between each terminal of outdoor fan motor normal?
(Refer to 12-4.)

Yes

Disconnect CN932 from the inverter P.C. board, and turn on the power supply.

Rotate the outdoor fan motor manually and measure the voltage of CN931.
Between 1(+) and 5(-)
Between 2(+) and 5(-)
Between 3(+) and 5(-)

No

(Fixed to either 5 or 0VDC)

Does the voltage between each terminal become 5 and 0V DC repeatedly?

No

Yes

Does the outdoor fan motor rotate smoothly?

No

Yes

Replace the outdoor fan motor.

Replace the inverter P.C. board.

J Check of power supply

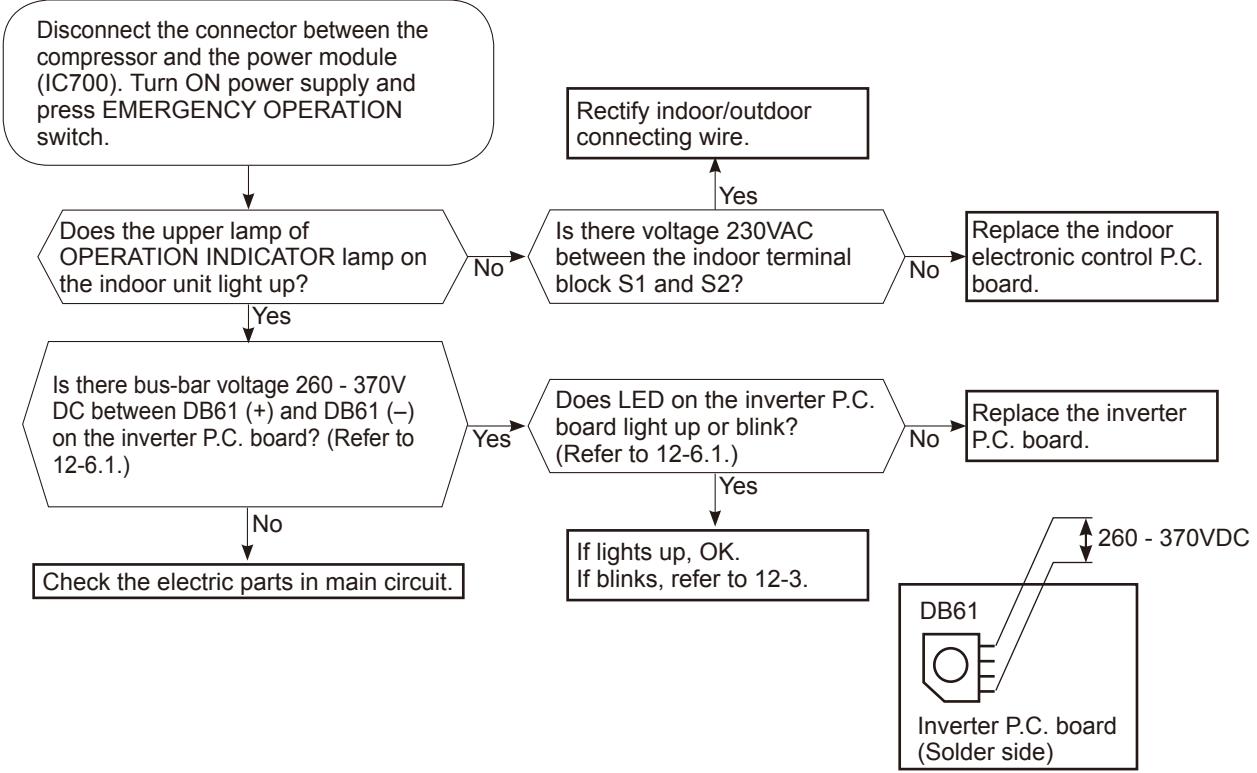

K Check of LEV (Expansion valve)

Turn ON the power supply.

<Preparation of the remote controller>

- ① While pressing both OPERATION SELECT button and TEMP \oplus button on the remote controller at the same time, press RESET button.
- ② First, release RESET button.
Hold down the other 2 buttons for another 3 seconds. Make sure that the indicators on the LCD screen shown in the right figure are all displayed. Then release the buttons.

Press STOP/OPERATE (OFF/ON) button of the remote controller (the set temperature is displayed) with the remote controller headed towards the indoor unit. ※1

Expansion valve operates in full-opening direction.

Do you hear the expansion valve "click, click....." ?
Do you feel the expansion valve vibrate when touching it ?

Yes

OK

No

Is LEV coil properly fixed to the expansion valve?

No

Properly fix the LEV coil to the expansion valve.

Yes

Does the resistance of LEV coil have the characteristics? (Refer to 12-4.)

Yes

Measure each voltage between connector pins of CN724 on the inverter P.C. board.
1. Pin③(-) — Pin①(+)
2. Pin④(-) — Pin①(+)
3. Pin⑤(-) — Pin①(+)
4. Pin⑥(-) — Pin①(+)
Is there about 3 - 5VAC between each?
NOTE: Measure the voltage by an analog tester.

No

Replace the inverter P.C. board.

No

Replace the LEV coil.

Yes

Replace the expansion valve.

FT25/35/50VG - [E1]

FT25/35/50VGK - [E1], [ET1] FT25/35/50VGK - [SC1]

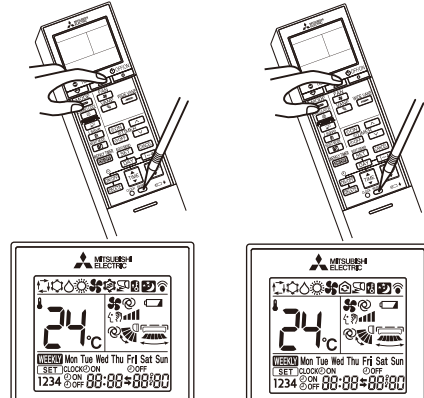

※1. Regardless of normal or abnormal condition, a short beep is emitted once the signal is received.

NOTE: After check of LEV, take the following steps.

1. Turn OFF the power supply and turn it ON again.
2. Press RESET button on the remote controller.

Ⓛ Check of inverter P.C. board

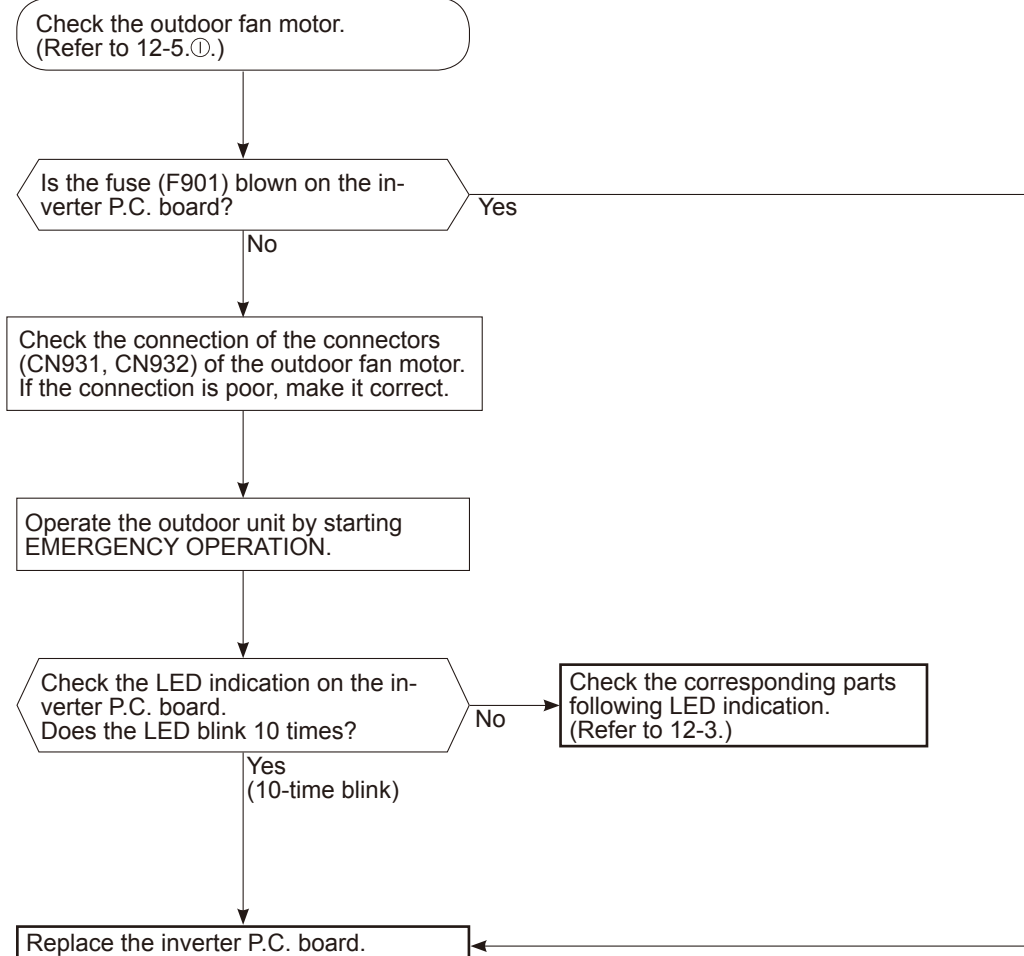

M How to check miswiring and serial signal error

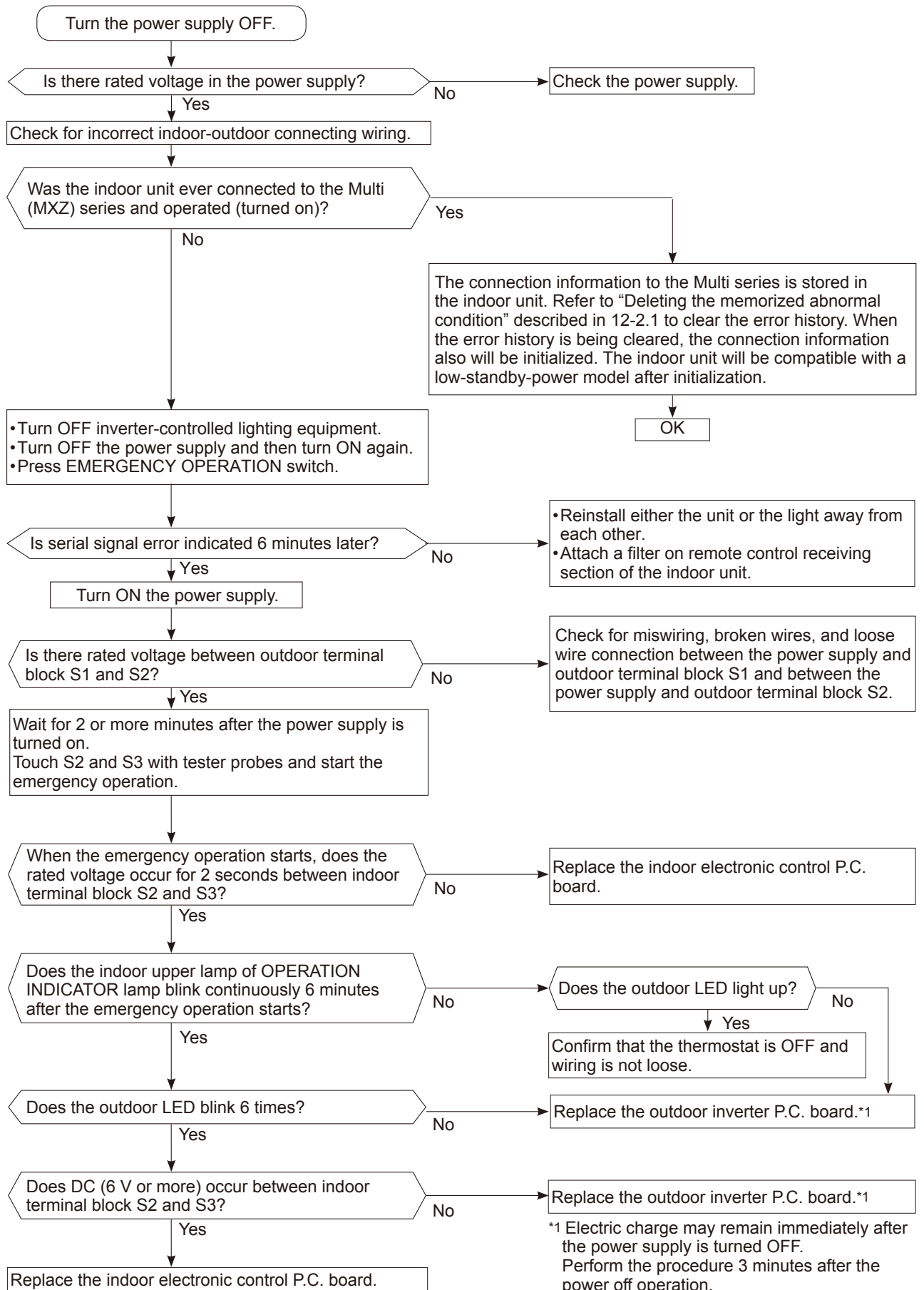



N Check of the outdoor refrigerant circuit

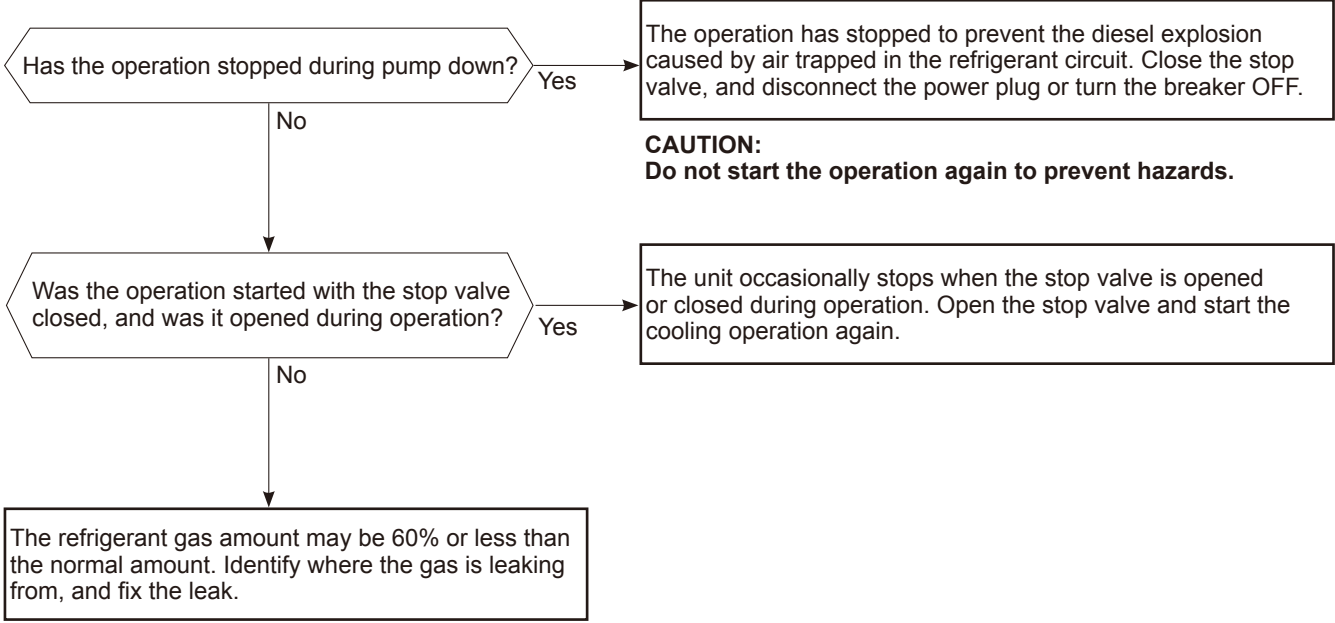

⊙ Electromagnetic noise enters into TV sets or radios

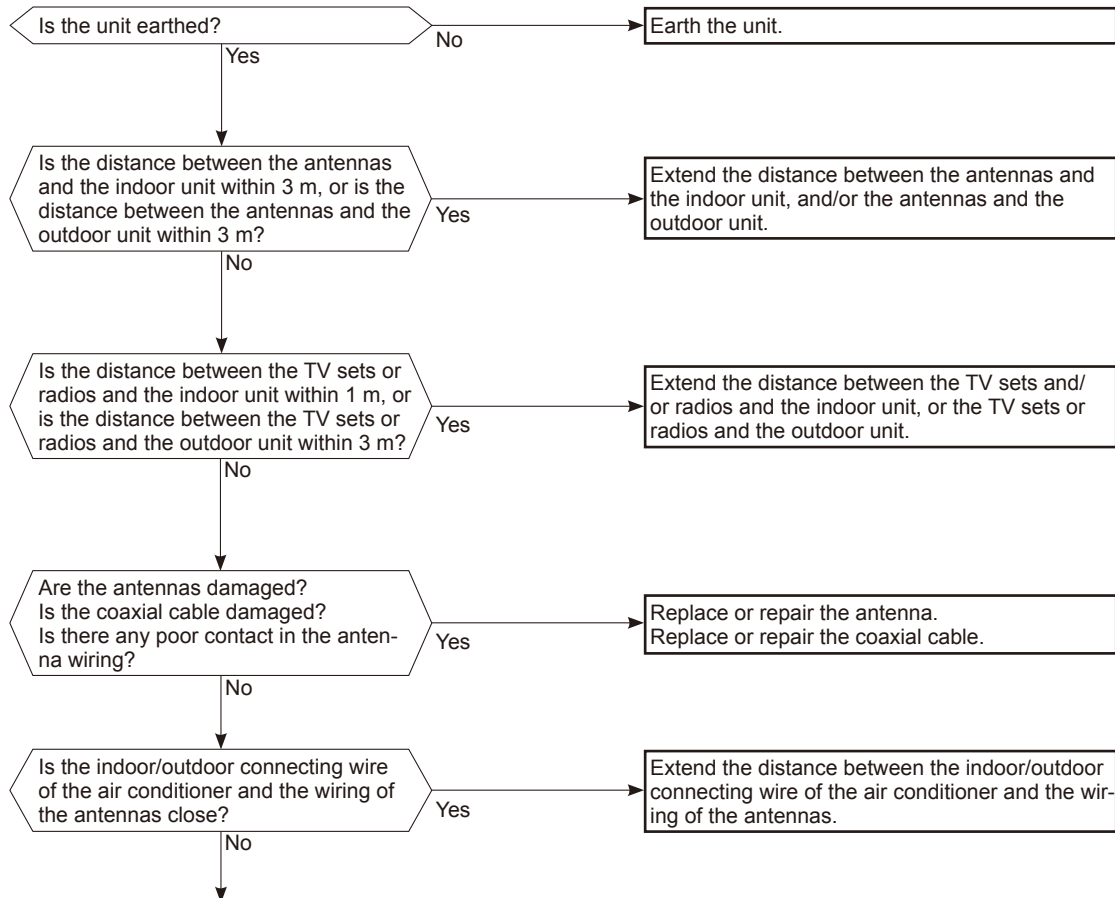

Even if all of the above conditions are fulfilled, the electromagnetic noise may enter, depending on the electric field strength or the installation condition (combination of specific conditions such as antennas or wiring). Check the following before asking for service.

1. Devices affected by the electromagnetic noise
TV sets, radios (FM/AM broadcast, shortwave)
2. Channel, frequency, broadcast station affected by the electromagnetic noise
3. Channel, frequency, broadcast station unaffected by the electromagnetic noise
4. Layout of:
indoor/outdoor unit of the air conditioner, indoor/outdoor wiring, earth wire, antennas, wiring from antennas, receiver
5. Electric field intensity of the broadcast station affected by the electromagnetic noise
6. Presence or absence of amplifier such as booster
7. Operation condition of air conditioner when the electromagnetic noise enters in
 - 1) Turn OFF the power supply once, and then turn ON the power supply. In this situation, check for the electromagnetic noise.
 - 2) Within 3 minutes after turning ON the power supply, press STOP/OPERATE (OFF/ON) button on the remote controller for power ON, and check for the electromagnetic noise.
 - 3) After a short time (3 minutes later after turning ON), the outdoor unit starts running. During operation, check for the electromagnetic noise.
 - 4) Press STOP/OPERATE (OFF/ON) button on the remote controller for power OFF, when the outdoor unit stops but the indoor/outdoor communication still runs on. In this situation, check for the electromagnetic noise.

12-6. TEST POINT DIAGRAM AND VOLTAGE

1. Inverter P.C. board

MUZ-FT25VGHZ MUZ-FT35VGHZ MUZ-FT50VGHZ

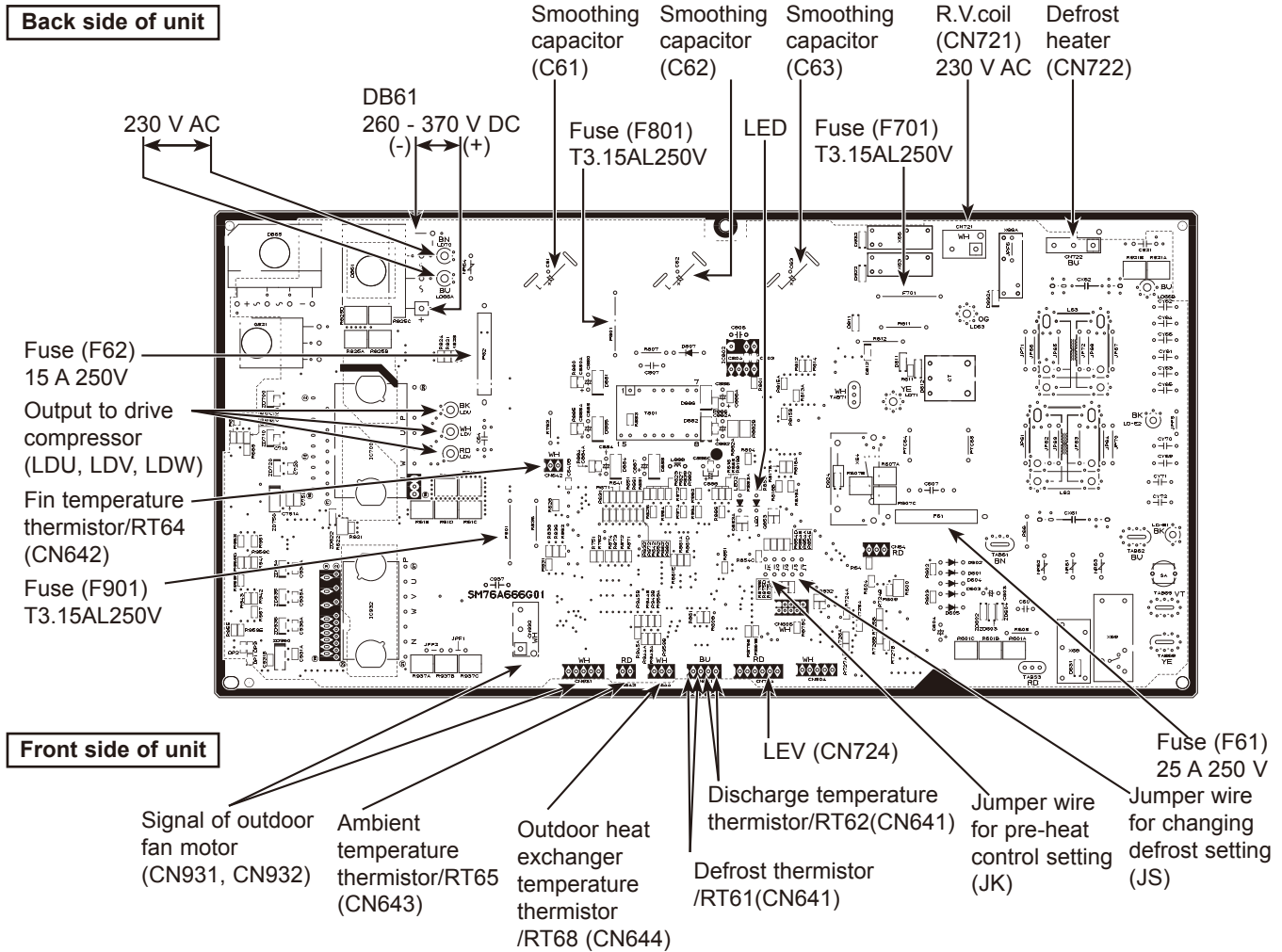

Defrost thermistor(RT61)
Ambient temperature thermistor(RT65)
Outdoor heat exchanger temperature thermistor(RT68)

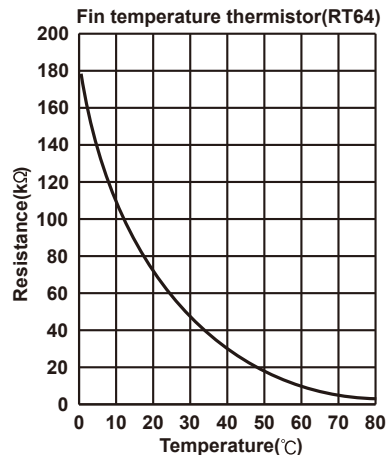
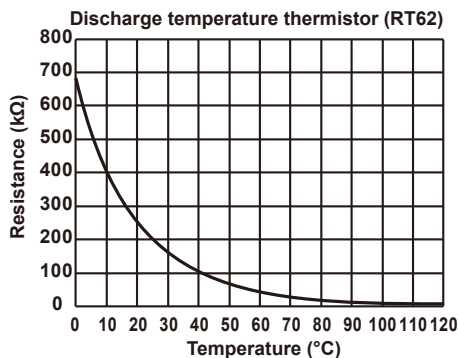
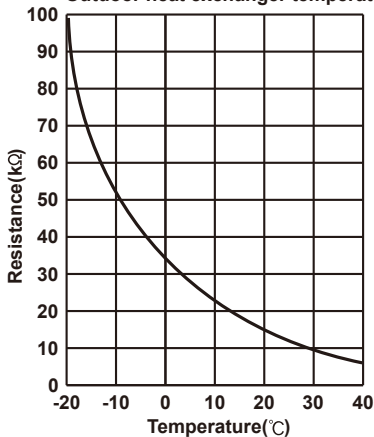

<"Terminal with locking mechanism" Detaching points>

The terminal which has the locking mechanism can be detached as shown below.
 There are 2 types (refer to (1) and (2)) of the terminal with locking mechanism.
 The terminal without locking mechanism can be detached by pulling it out.
 Check the shape of the terminal before detaching.

(1) Slide the sleeve and check if there is a locking lever or not.

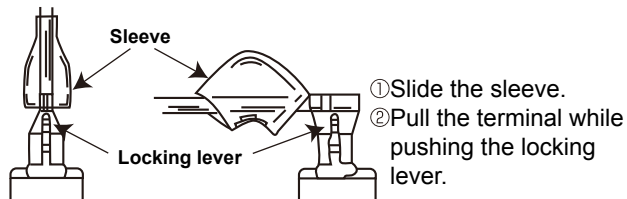

(2) The terminal with this connector has the locking mechanism.

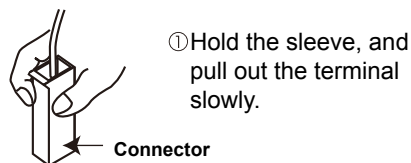

13-1. MUZ-FT25VGHZ

NOTE: Turn OFF the power supply before disassembly.

→ : Indicates the visible parts in the photos.
 --- : Indicates the invisible parts in the photos.

| OPERATING PROCEDURE | PHOTOS/FIGURES |
|--|---|
| <p>1. Removing the cabinet</p> <ol style="list-style-type: none"> (1) Remove the screws fixing the service panel. (2) Pull down the service panel and remove it. (3) Disconnect the power supply cord and indoor/outdoor connecting wire. (4) Remove the screws fixing the top panel. (5) Remove the top panel. (6) Remove the screws fixing the cabinet. (7) Remove the cabinet. (8) Remove the screws fixing the back panel. (9) Remove the screws of the terminal block support and the back panel. (10) Remove the back panel. <p>Photo 2</p> | <p>Photo 1</p> <p>Photo 3</p> |

OPERATING PROCEDURE

2. Removing the inverter assembly and inverter P.C. board

- (1) Remove the cabinet and panels. (Refer to section 1.)
- (2) Disconnect the lead wire to the reactor and the following connectors:
 - <Inverter P.C. board>
 - CN721 (R.V. coil)
 - CN722 (Base heater)
 - CN931, CN932 (Fan motor)
 - CN641 (Defrost thermistor and discharge temperature thermistor)
 - CN643 (Ambient temperature thermistor)
 - CN644 (Outdoor heat exchanger temperature thermistor)
 - CN724 (LEV)
- (3) Remove the compressor connector (CN61).
- (4) Remove the screws fixing the heat sink support and the separator.
- (5) Remove the fixing screw of the P.B. support and the separator.
- (6) Remove the fixing screws of the terminal block support and the back panel.
- (7) Remove the inverter assembly.
- (8) Remove the heat sink support from the P.C. board support.
- (9) Remove the screw of the inverter P.C. board and remove the inverter P.C. board from the P.C. board support.

* Connection procedure when attaching the inverter P.C. board (Photo 5)

1. Connect the lead wires of the heat exchanger temperature thermistor to the connector on the inverter P.C. board. Pull the lead wires of the heat exchanger temperature thermistor toward you and put them on the left hook on the P.C. board support so that the other lead wires are bundled up as shown in Photo 5.
2. Connect the lead wires of the expansion valve coil to the connector on the inverter P.C. board. Pull the lead wires of the expansion valve coil toward you and put them on the right hook on the P.C. board support so that the other lead wires are bundled up as shown in Photo 5.

Photo 6 (Inverter assembly)

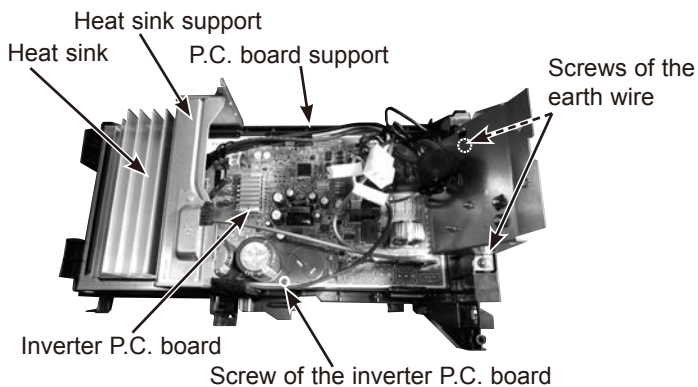

PHOTOS/FIGURES

Photo 4

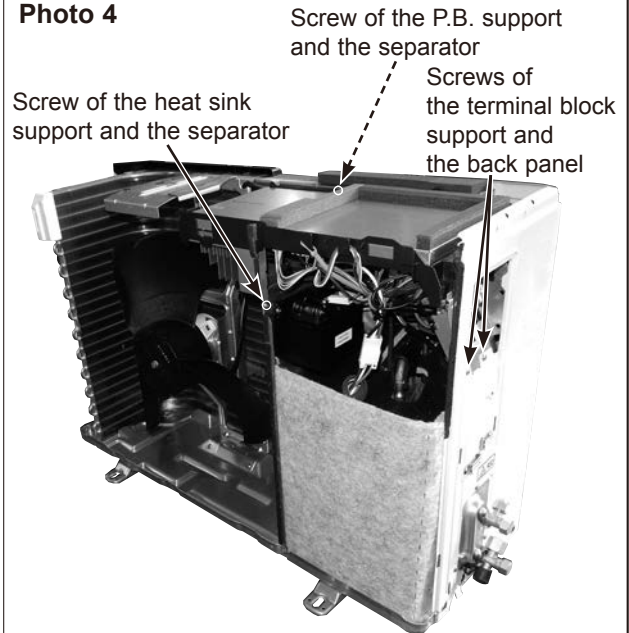
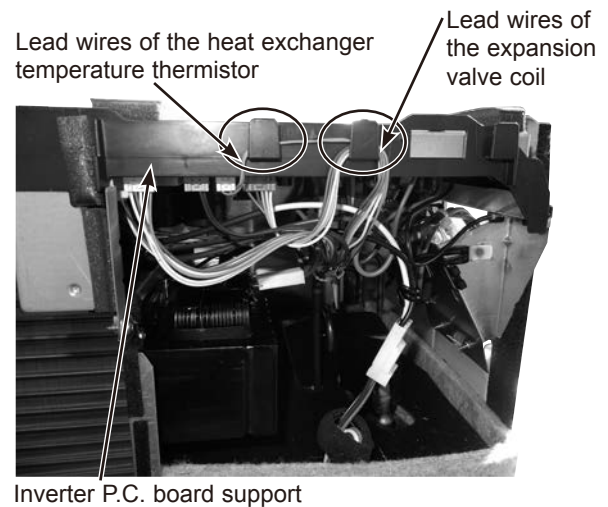

Photo 5





OPERATING PROCEDURE

3. Removing R.V. coil

- (1) Remove the cabinet and panels. (Refer to section 1.)
- (2) Disconnect the following connectors:
<Inverter P.C. board>
CN721 (R.V. coil)
- (3) Remove the R.V. coil.

4. Removing the discharge temperature thermistor, defrost thermistor, outdoor heat exchanger temperature thermistor and ambient temperature thermistor

- (1) Remove the cabinet and panels. (Refer to section 1.)
- (2) Disconnect the lead wire to the reactor and the following connectors:
<Inverter P.C. board>
CN641 (Defrost thermistor and discharge temperature thermistor)
CN643 (Ambient temperature thermistor)
CN644 (Outdoor heat exchanger temperature thermistor)
- (3) Pull out the discharge temperature thermistor from its holder.
- (4) Pull out the defrost thermistor from its holder.
- (5) Pull out the outdoor heat exchanger temperature thermistor from its holder.
- (6) Pull out the ambient temperature thermistor from its holder.

5. Removing outdoor fan motor

- (1) Remove the cabinet and panels. (Refer to section 1.)
- (2) Disconnect the following connectors:
<Inverter P.C. board>
CN931, CN932 (Fan motor)
- (3) Remove the propeller fan nut.
- (4) Remove the propeller fan.
- (5) Remove the screws fixing the fan motor.
- (6) Remove the fan motor.

PHOTOS/FIGURES

Photo 7

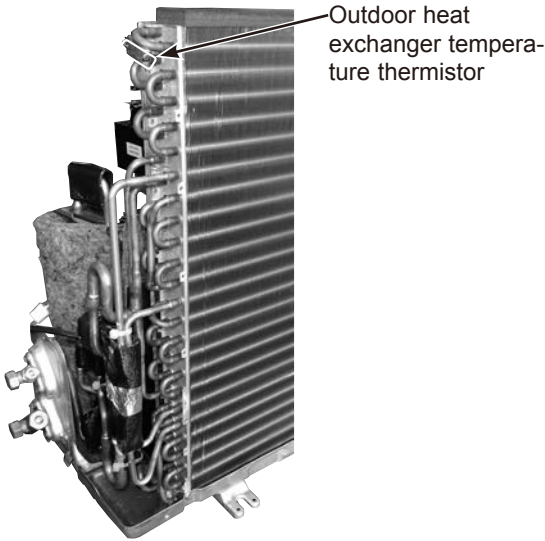
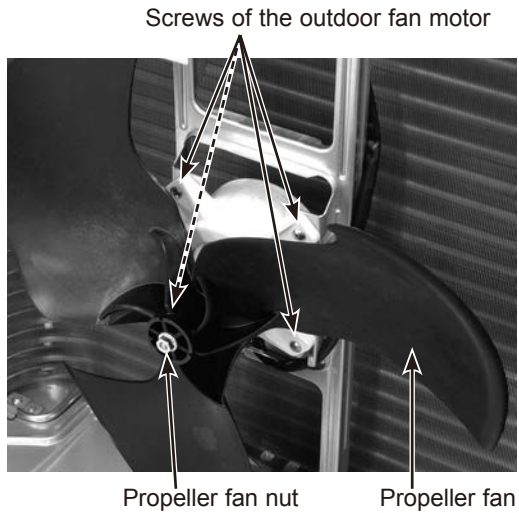

Photo 8



OPERATING PROCEDURE

6. Removing the compressor and 4-way valve

- (1) Remove the cabinet and panels. (Refer to section 1.)
- (2) Remove the inverter assembly. (Refer to section 2.)
- (3) Recover gas from the refrigerant circuit.
NOTE: Recover gas from the pipes until the pressure gauge shows 0 kg/cm² (0 MPa).
- (4) Detach the brazed part of the suction and the discharge pipe connected with compressor.
- (5) Remove the compressor nuts.
- (6) Remove the compressor.
- (7) Detach the brazed part of pipes connected with 4-way valve.

PHOTOS/FIGURES

Photo 9

Discharge pipe
brazed part

Suction pipe
brazed part

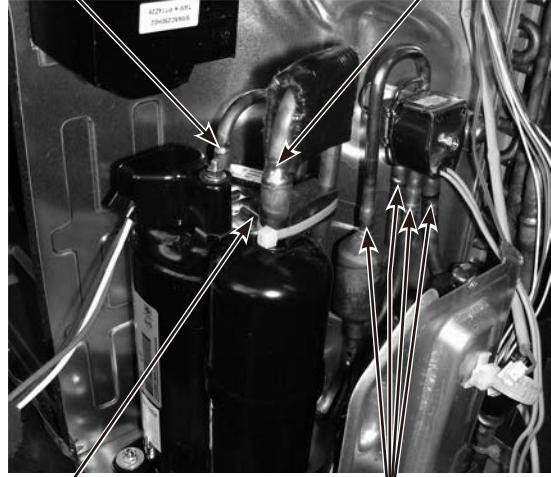

Discharge
temperature
thermistor

Brazed parts of 4-way valve

13-2. MUZ-FT35VGHZ MUZ-FT50VGHZ

NOTE: Turn OFF the power supply before disassembly.

OPERATING PROCEDURE

1. Removing the cabinet

- (1) Remove the screws of the service panel.
- (2) Remove the screws of the top panel.
- (3) Remove the screw of the valve cover.
- (4) Remove the service panel.
- (5) Remove the top panel.
- (6) Remove the valve cover.
- (7) Disconnect the power supply cord and indoor/outdoor connecting wire.
- (8) Remove the screws of the cabinet.
- (9) Remove the cabinet.
- (10) Remove the screws of the back panel.
- (11) Remove the back panel.

Photo 2

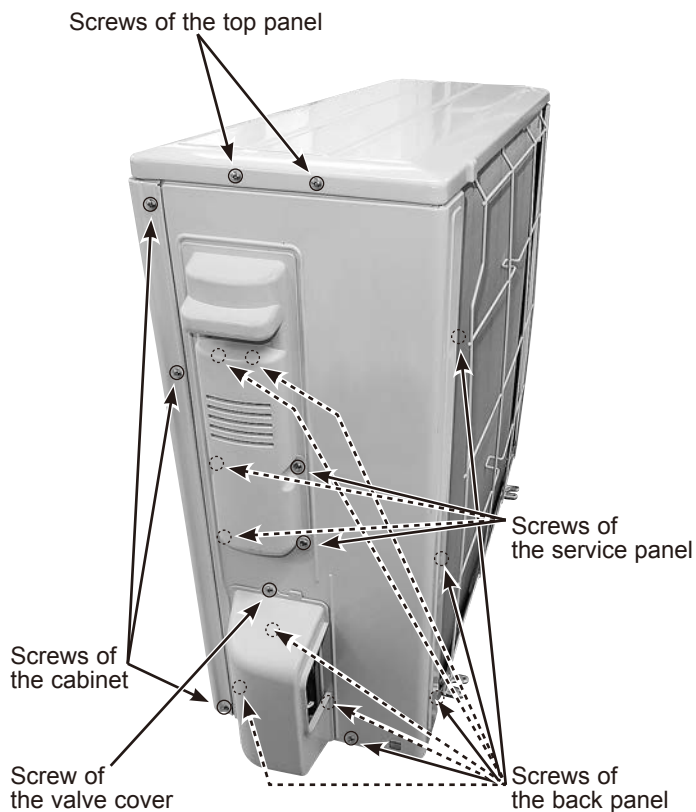

PHOTOS/FIGURES

Photo 1

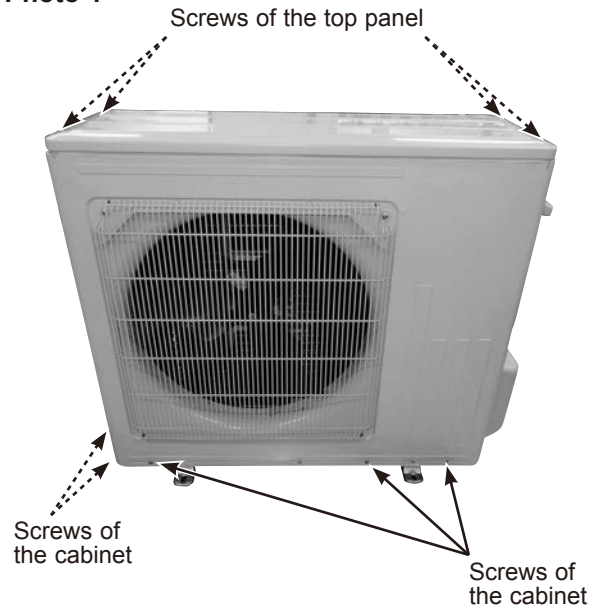

OPERATING PROCEDURE

2. Removing the inverter assembly and inverter P.C. board

- (1) Remove the cabinet and panels. (Refer to section 1.)
- (2) Disconnect the lead wire to the reactor and the following connectors:
 - <Inverter P.C. board>
 - CN721 (R.V. coil)
 - CN931, CN932 (Fan motor)
 - CN641 (Defrost thermistor and discharge temperature thermistor)
 - CN643 (Ambient temperature thermistor)
 - CN644 (Outdoor heat exchanger temperature thermistor)
 - CN724 (LEV)
- (3) Remove the compressor connector (CN61).
- (4) Remove the screws fixing the heat sink support and the separator.
- (5) Remove the fixing screw of the P.B. support and the separator.
- (6) Remove the fixing screws of the terminal block support and the back panel.
- (7) Remove the inverter assembly.
- (8) Remove the heat sink support from the P.C. board support.
- (9) Remove the screw of the inverter P.C. board and remove the inverter P.C. board from the P.C. board support.

* Connection procedure when attaching the inverter P.C. board (Photo 4)

1. Connect the lead wires of the heat exchanger temperature thermistor, the defrost thermistor, and the discharge temperature thermistor to the connector on the inverter P.C. board. Pull the lead wires toward you and put them on the right hook on the P.C. board support.
2. Connect the lead wires of the LEV to the connector on the inverter P.C. board. Pull the lead wires toward you and put them on the right hook on the P.C. board support.
3. Connect the lead wires of the ambient temperature thermistor to the connector on the inverter P.C. board. Pull the lead wires toward you and put them on the left hook on the P.C. board support so that the fan motor lead wires are bundled up as shown in Photo 4.

PHOTOS/FIGURES

Photo 3

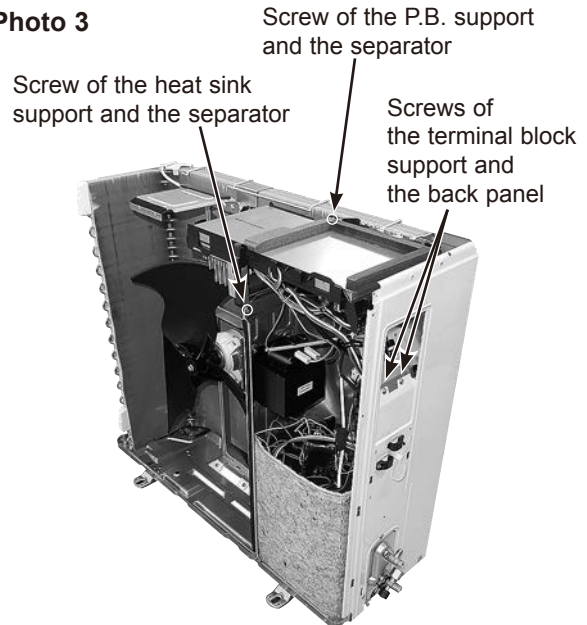

Photo 4

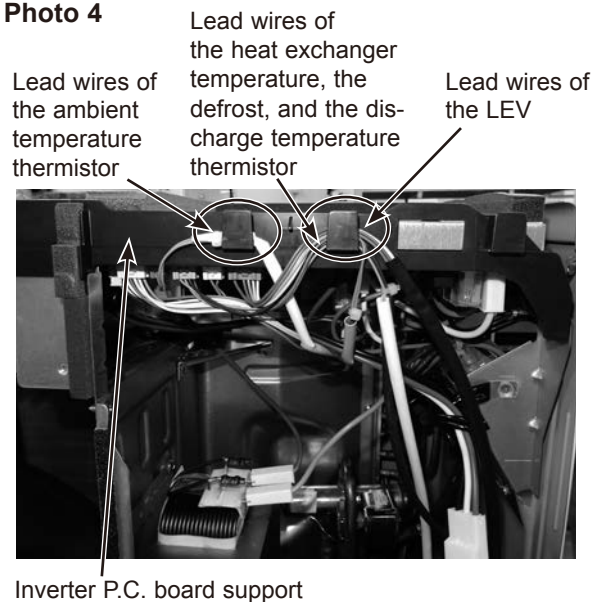
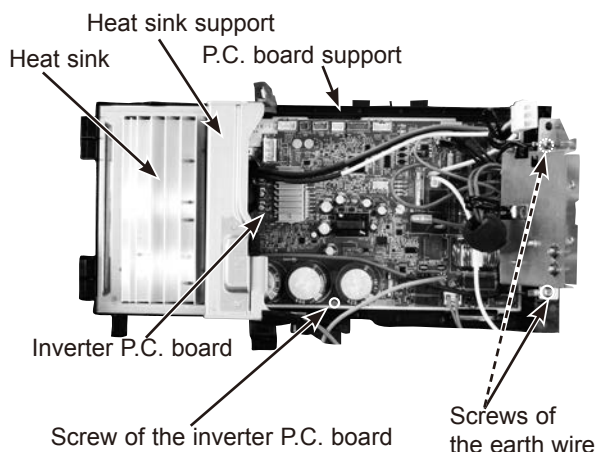

Photo 5 (Inverter assembly)





OPERATING PROCEDURE

3. Removing R. V. coil

- (1) Remove the cabinet and panels. (Refer to section 1.)
- (2) Disconnect the following connectors:
<Inverter P.C. board>
CN721 (R.V. coil)
- (3) Remove the R.V. coil.

4. Removing the discharge temperature thermistor, defrost thermistor, outdoor heat exchanger temperature thermistor and ambient temperature thermistor

- (1) Remove the cabinet and panels. (Refer to section 1.)
- (2) Disconnect the lead wire to the reactor and the following connectors:
<Inverter P.C. board>
CN641 (Defrost thermistor and discharge temperature thermistor)
CN643 (Ambient temperature thermistor)
CN644 (Outdoor heat exchanger temperature thermistor)
- (3) Pull out the discharge temperature thermistor from its holder.
- (4) Pull out the defrost thermistor from its holder.
- (5) Pull out the outdoor heat exchanger temperature thermistor from its holder.
- (6) Pull out the ambient temperature thermistor from its holder.

5. Removing outdoor fan motor

- (1) Remove the cabinet and panels. (Refer to section 1)
- (2) Disconnect the following connectors:
<Inverter P.C. board>
CN931, CN932 (Fan motor)
- (3) Remove the propeller fan nut.
- (4) Remove the propeller fan.
- (5) Remove the screws fixing the fan motor.
- (6) Remove the fan motor.

PHOTOS/FIGURES

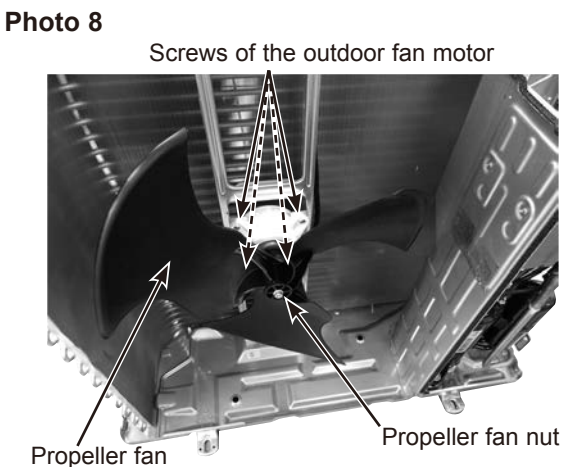
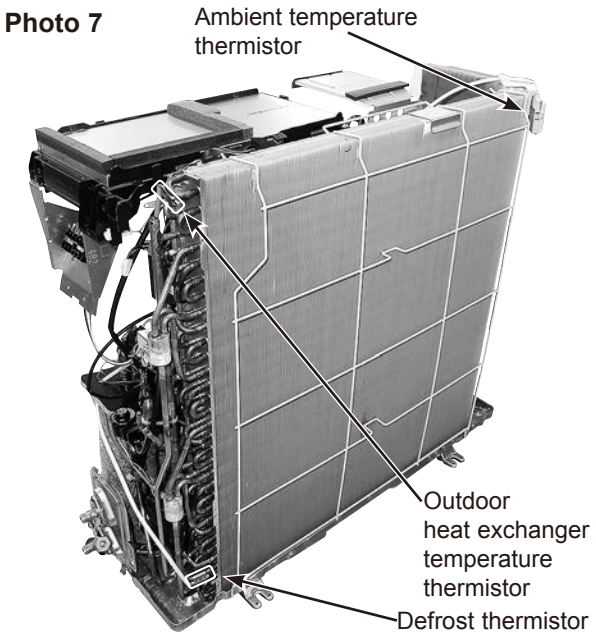
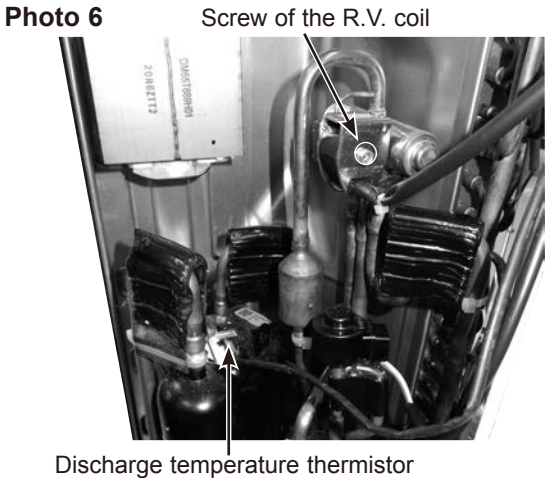

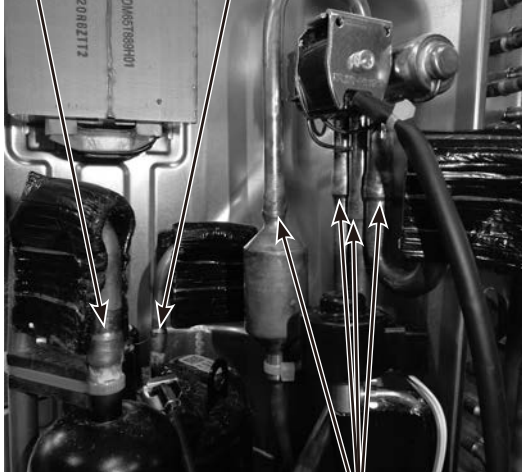

| OPERATING PROCEDURE | PHOTOS/FIGURES |
|--|---|
| <p>6. Removing the compressor and 4-way valve</p> <p>(1) Remove the cabinet and panels. (Refer to section 1.)</p> <p>(2) Remove the inverter assembly. (Refer to section 2.)</p> <p>(3) Recover gas from the refrigerant circuit.</p> <p>NOTE: Recover gas from the pipes until the pressure gauge shows 0 kg/cm² (0 MPa).</p> <p>(4) Detach the brazed part of the suction and the discharge pipe connected with compressor.</p> <p>(5) Remove the compressor nuts.</p> <p>(6) Remove the compressor.</p> <p>(7) Detach the brazed part of pipes connected with 4-way valve.</p> | <p>Photo 9</p> <p>Suction pipe brazed part</p> <p>Discharge pipe brazed part</p>  <p>Brazed parts of 4-way valve</p> |

MITSUBISHI ELECTRIC CORPORATION

HEAD OFFICE: TOKYO BUILDING, 2-7-3, MARUNOUCHI, CHIYODA-KU, TOKYO 100-8310, JAPAN

© Copyright 2020 MITSUBISHI ELECTRIC CORPORATION

Published: Jun. 2020. No. OBH865

Made in Japan

Specifications are subject to change without notice.