

INDOOR UNIT

No. OBH864

SERVICE MANUAL

Models

MSZ-FT25VG - E1

MSZ-FT25VGK - E1, ET1, SC1

MSZ-FT35VG - E1

MSZ-FT35VGK - E1, ET1, SC1

MSZ-FT50VG - E1

MSZ-FT50VGK - E1, ET1, SC1

Outdoor unit service manual
MUZ-FT·VG Series (OBH865)

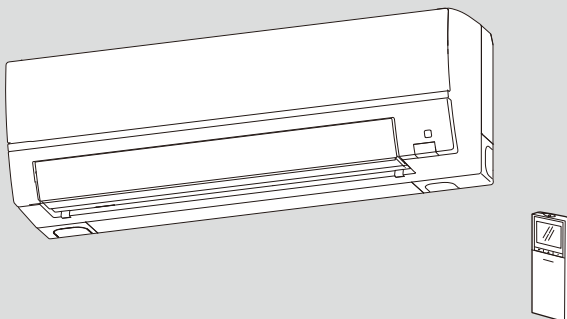

CONTENTS

1. TECHNICAL CHANGES	2
2. PART NAMES AND FUNCTIONS	3
3. SPECIFICATION	4
4. NOISE CRITERIA CURVES	5
5. OUTLINES AND DIMENSIONS	6
6. WIRING DIAGRAM	7
7. REFRIGERANT SYSTEM DIAGRAM	10
8. SERVICE FUNCTIONS	11
9. MICROPROCESSOR CONTROL	13
10. TROUBLESHOOTING	22
11. DISASSEMBLY INSTRUCTIONS	36

PARTS CATALOG (OBB864)

Use the specified refrigerant only

Never use any refrigerant other than that specified.

Doing so may cause a burst, an explosion, or fire when the unit is being used, serviced, or disposed of.

Correct refrigerant is specified in the manuals and on the spec labels provided with our products.

We will not be held responsible for mechanical failure, system malfunction, unit breakdown or accidents caused by failure to follow the instructions.

<Preparation before the repair service>

- Prepare the proper tools.
- Prepare the proper protectors.
- Provide adequate ventilation.
- After stopping the operation of the air conditioner, turn off the power-supply breaker and remove the power plug.
- Discharge the capacitor before the work involving the electric parts.

<Precautions during the repair service>

- Do not perform the work involving the electric parts with wet hands.
- Do not pour water into the electric parts.
- Do not touch the refrigerant.
- Do not touch the hot or cold areas in the refrigeration cycle.
- When the repair or the inspection of the circuit needs to be done without turning off the power, exercise great caution not to touch the live parts.

1

TECHNICAL CHANGES

MSZ-FT25VG - E1

MSZ-FT35VG - E1

MSZ-FT50VG - E1

MSZ-FT25VGK - E1, ET1, SC1

MSZ-FT35VGK - E1, ET1, SC1

MSZ-FT50VGK - E1, ET1, SC1

1. New model

2

PART NAMES AND FUNCTIONS

MSZ-FT25VG MSZ-FT35VG MSZ-FT50VG
MSZ-FT25VGK MSZ-FT35VGK MSZ-FT50VGK

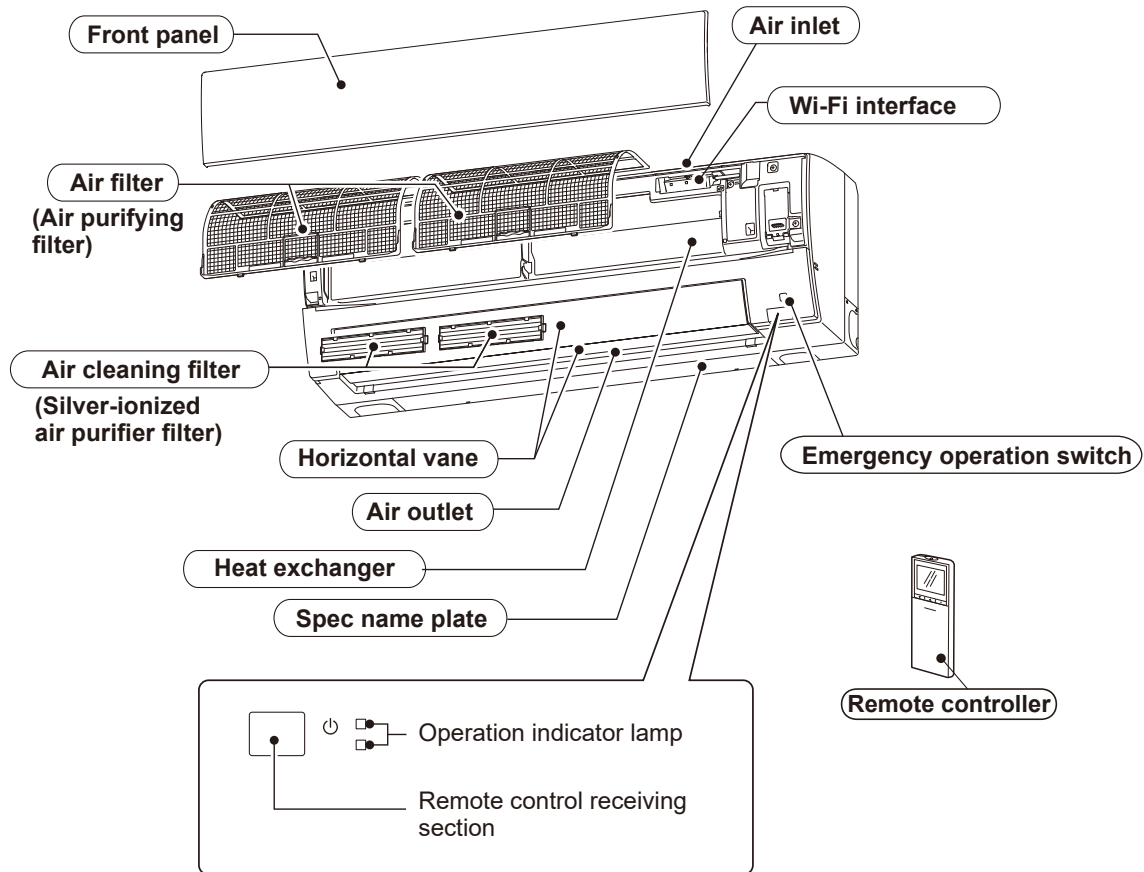

ACCESSORIES

Model	MSZ-FT25VG MSZ-FT25VGK MSZ-FT35VG MSZ-FT35VGK MSZ-FT50VG MSZ-FT50VGK
① Installation plate	1
② Installation plate fixing screw 4 × 25 mm	5
③ Wireless remote controller	1
④ Felt tape (For left or left-rear piping)	1
⑤ Battery (AAA) for remote controller	2

3

SPECIFICATION

Indoor model				MSZ-FT25VG MSZ-FT25VGK	MSZ-FT35VG MSZ-FT35VGK	MSZ-FT50VG MSZ-FT50VGK		
Power supply				Single phase 230 V, 50 Hz				
Electrical data	Power input *1	Cooling	W	27	30	36		
		Heating		39	40	47		
	Running current *1	Cooling	A	0.26	0.29	0.33		
		Heating		0.35	0.36	0.41		
Fan motor	Model			RC0J30-CV				
	Current *1	Cooling	A	0.26	0.29	0.33		
Heating			0.35	0.36	0.41			
Dimensions W × H × D			mm	838 × 280 × 229				
Weight			kg	10				
Special remarks	Air direction			5				
	Airflow	Cooling	Super High	m/h	738	786		
			High		624	642	720	
			Med.		492	498	588	
			Low		354	366	456	
			Super Low		234		330	
			Super High		792	882	930	
		Heating	High		720	810	864	
			Med.		540	612	684	
			Low		378	414	504	
			Super Low		234		330	
			Super High		46	47	48	
			High		41	42	45	
	Sound level	Cooling	Med.	dB(A)	36		40	
			Low		27		34	
			Super Low		19		28	
			Super High		49	52	54	
			High		46	49	51	
			Med.		39	42	45	
		Heating	Low		31	33	36	
			Super Low		19		28	
			Super High		1,100	1,150		
			High		970	990	1,080	
			Med.		820	830	930	
			Low		660	670	780	
	Fan speed	Cooling	Super Low	rpm	500		630	
			Super High		1,160	1,260	1,320	
			High		1,080	1,180	1,240	
Med.			880		960	1,040		
Low			690		730	840		
Heating		Super Low	500		630			
		Fan speed regulator			5			
		Remote controller model			□ E1 □, □ ET1 □ : SH20E , □ SC1 □ : SH20D			

NOTE: Test conditions are based on ISO 5151.

Cooling: Indoor Dry-bulb temperature 27°C Wet-bulb temperature 19°C
Outdoor Dry-bulb temperature 35°C Wet-bulb temperature 24°C

Heating: Indoor Dry-bulb temperature 20°C Wet-bulb temperature 15°C
Outdoor Dry-bulb temperature 7°C Wet-bulb temperature 6°C

*1 Measured under rated operating frequency.

Specifications and rated conditions of main electric parts

Model		MSZ-FT25/35/50VG MSZ-FT25/35/50VGK
Fuse	(F11)	T3.15AL250V
Horizontal vane motor	(MV)	12 V DC
Varistor	(NR11)	470 V
Terminal block	(TB)	3P

4

NOISE CRITERIA CURVES

MSZ-FT25VG MSZ-FT25VGK

FUNCTION	SPL(dB(A))	LINE
COOLING	46	● — ●
HEATING	49	□ - - □

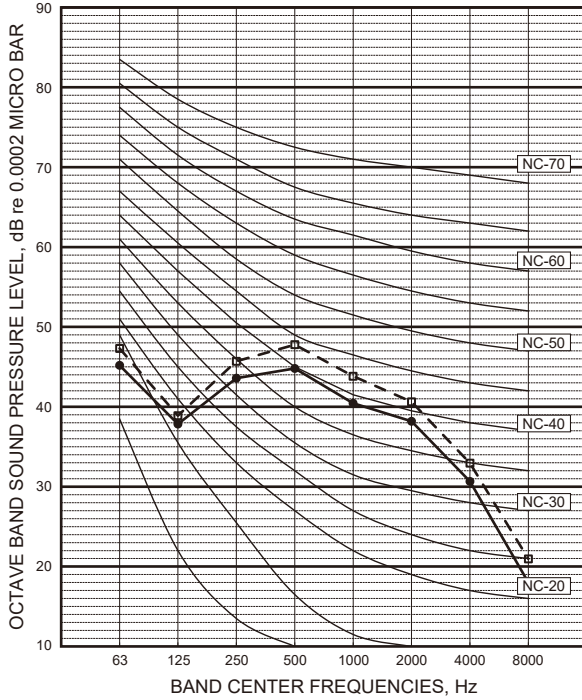

MSZ-FT35VG MSZ-FT35VGK

FUNCTION	SPL(dB(A))	LINE
COOLING	47	● — ●
HEATING	52	□ - - □

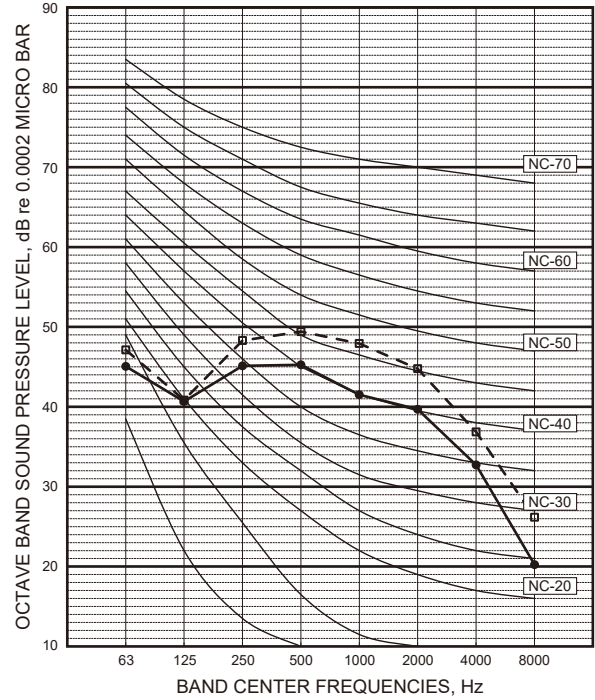

MSZ-FT50VG MSZ-FT50VGK

FUNCTION	SPL(dB(A))	LINE
COOLING	48	● — ●
HEATING	54	□ - - □

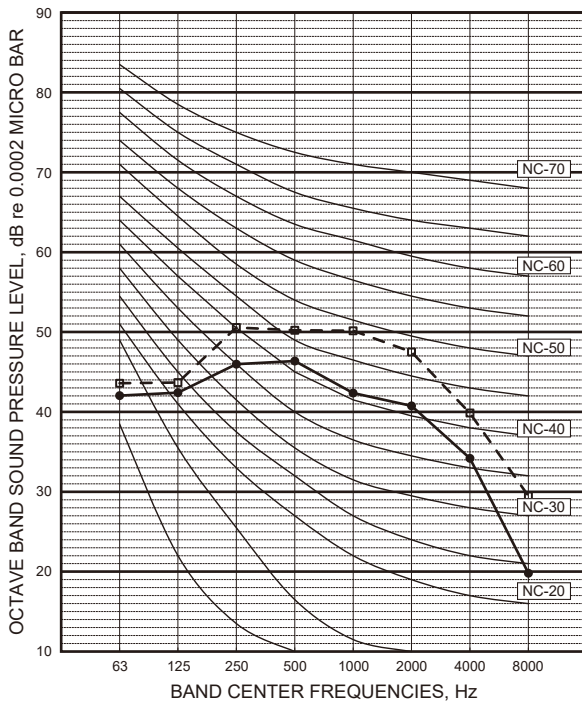

Test conditions

Cooling: Dry-bulb temperature 27°C
Wet-bulb temperature 19°C

Heating: Dry-bulb temperature 20°C
Wet-bulb temperature 15°C

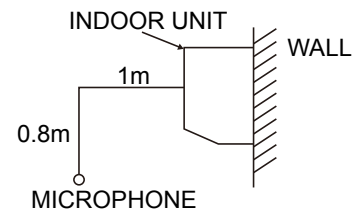

5

OUTLINES AND DIMENSIONS

MSZ-FT25VG MSZ-FT35VG MSZ-FT50VG
 MSZ-FT25VGK MSZ-FT35VGK MSZ-FT50VGK

Unit: mm

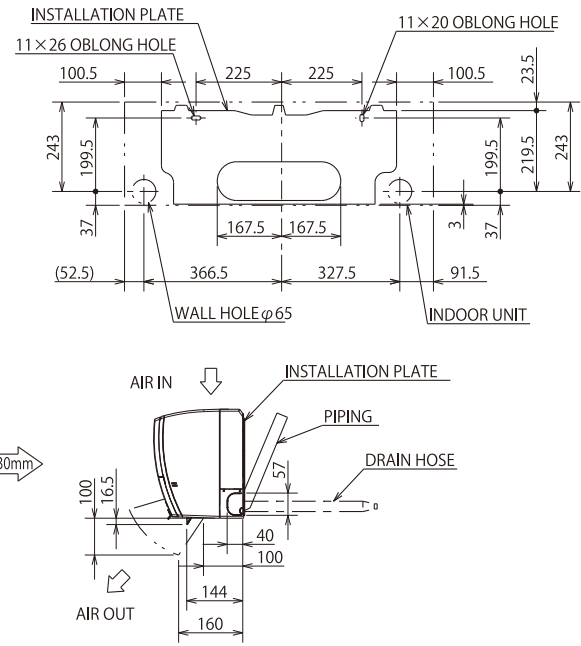
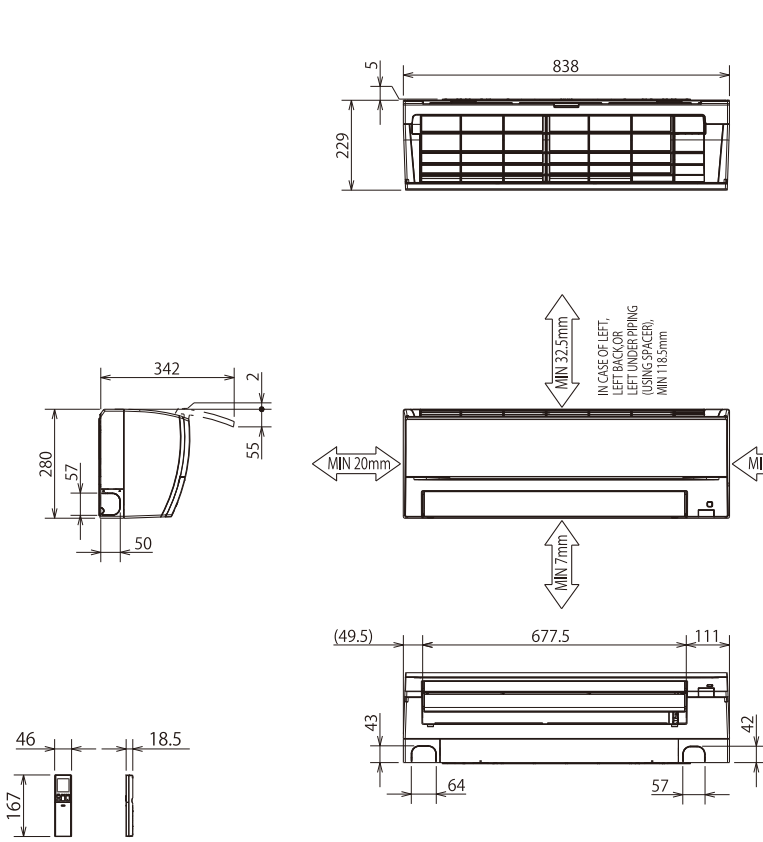

MSZ-FT25/35/50VG-**[E]**
 MSZ-FT25/35/50VGK-**[E]**
 MSZ-FT25/35/50VGK-**[ET]**

PIPING	INSULATION	$\phi 37$ O.D
	LIQUID LINE	$\phi 7 - 0.39$ m (FLARED CONNECTION $\phi 6.35$)
	GAS LINE	$\phi 9.52 - 0.34$ m (FLARED CONNECTION $\phi 9.52$)
	DRAIN HOSE	INSULATION $\phi 29$ CONNECTED PART $\phi 16$ O.D

MSZ-FT25/35/50VGK-**[SC]**

PIPING	INSULATION	$\phi 37$ O.D
	LIQUID LINE	$\phi 7 - 0.59$ m (FLARED CONNECTION $\phi 6.35$)
	GAS LINE	$\phi 9.52 - 0.54$ m (FLARED CONNECTION $\phi 9.52$)
	DRAIN HOSE	INSULATION $\phi 29$ CONNECTED PART $\phi 16$ O.D

6

WIRING DIAGRAM

MSZ-FT25VG- E1

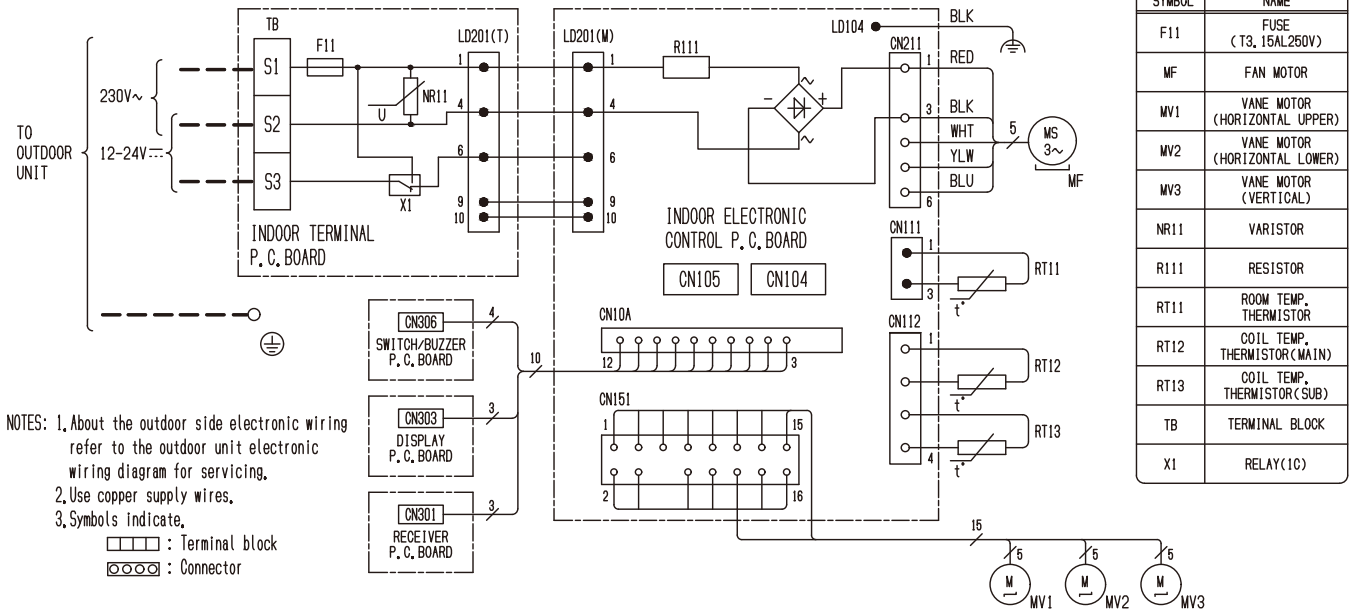

MSZ-FT35VG- E1 MSZ-FT50VG- E1

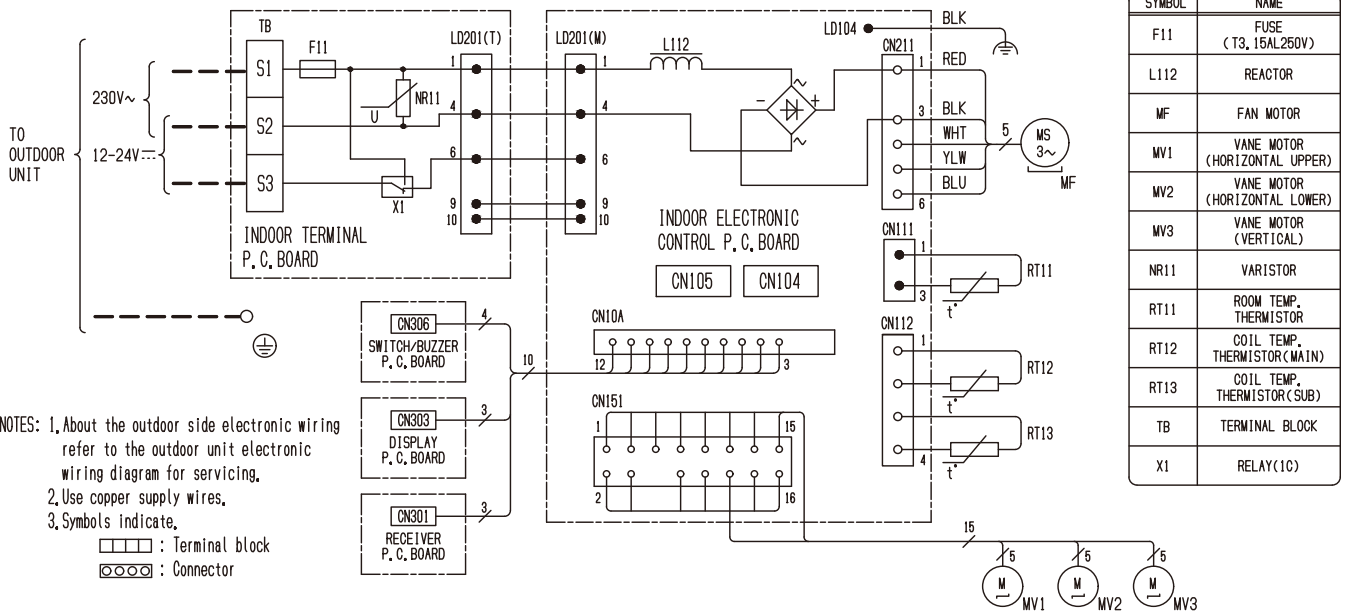

MSZ-FT25VGK- [E1], [SC1]

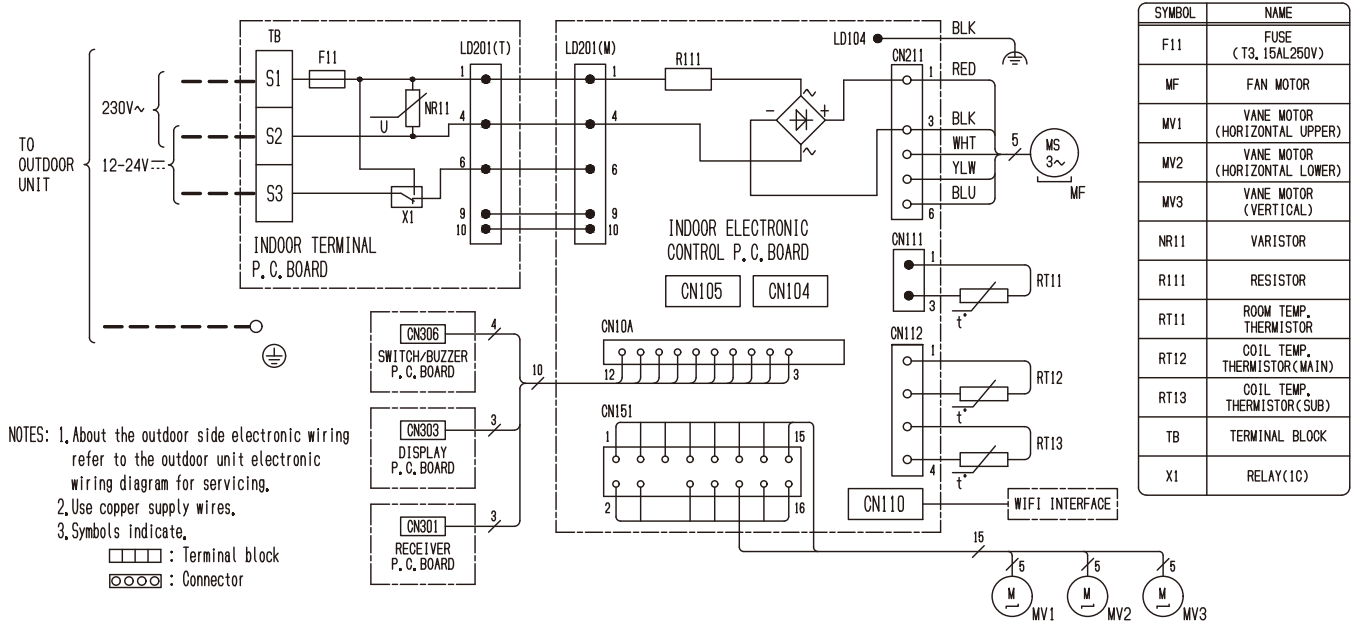

MSZ-FT35VGK- [E1], [SC1] **MSZ-FT50VGK-** [E1], [SC1]

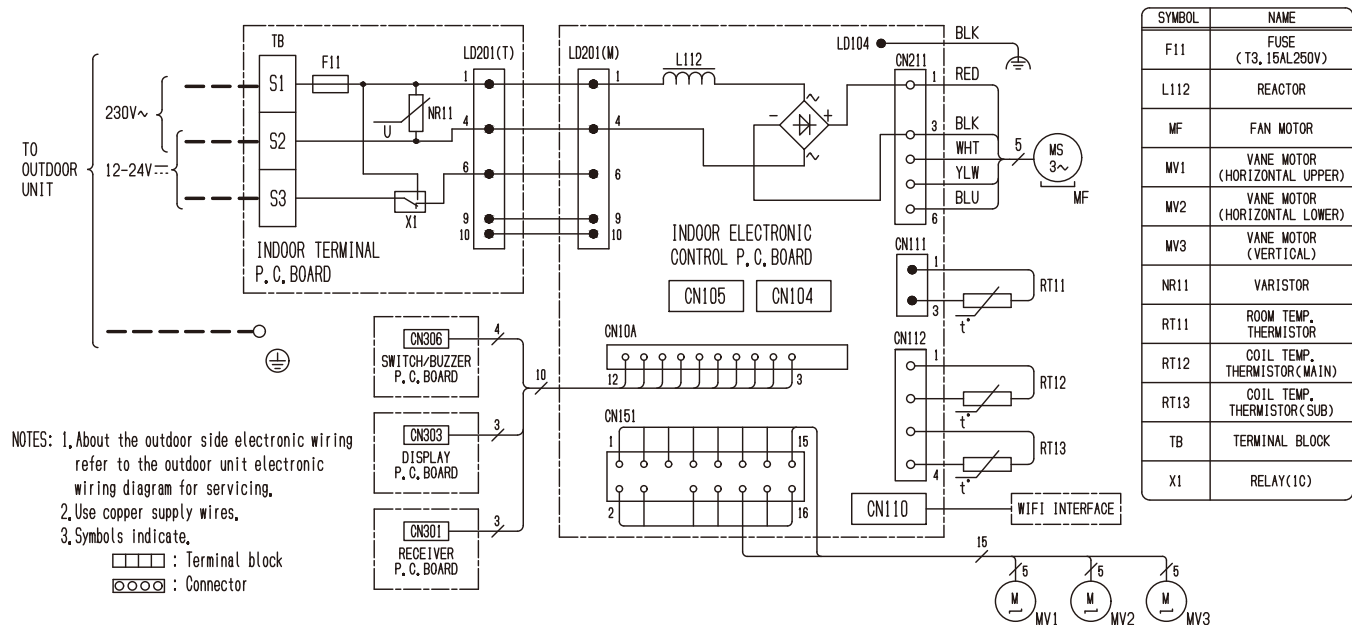

MSZ-FT25VGK- [ET1]

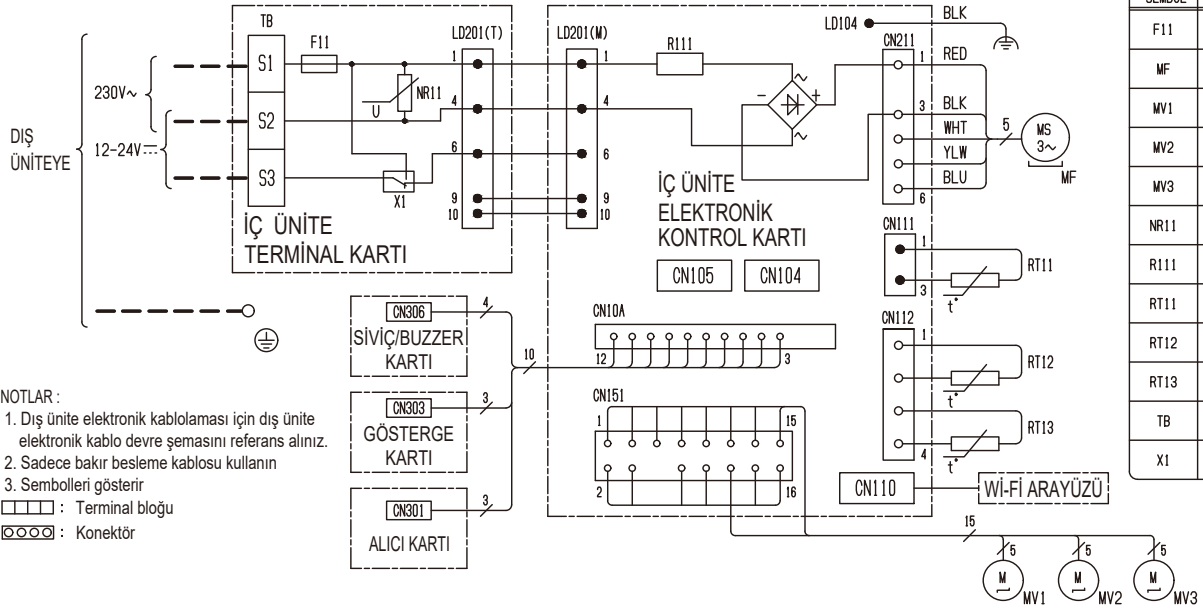

MSZ-FT35VGK- [ET1] MSZ-FT50VGK- [ET1]

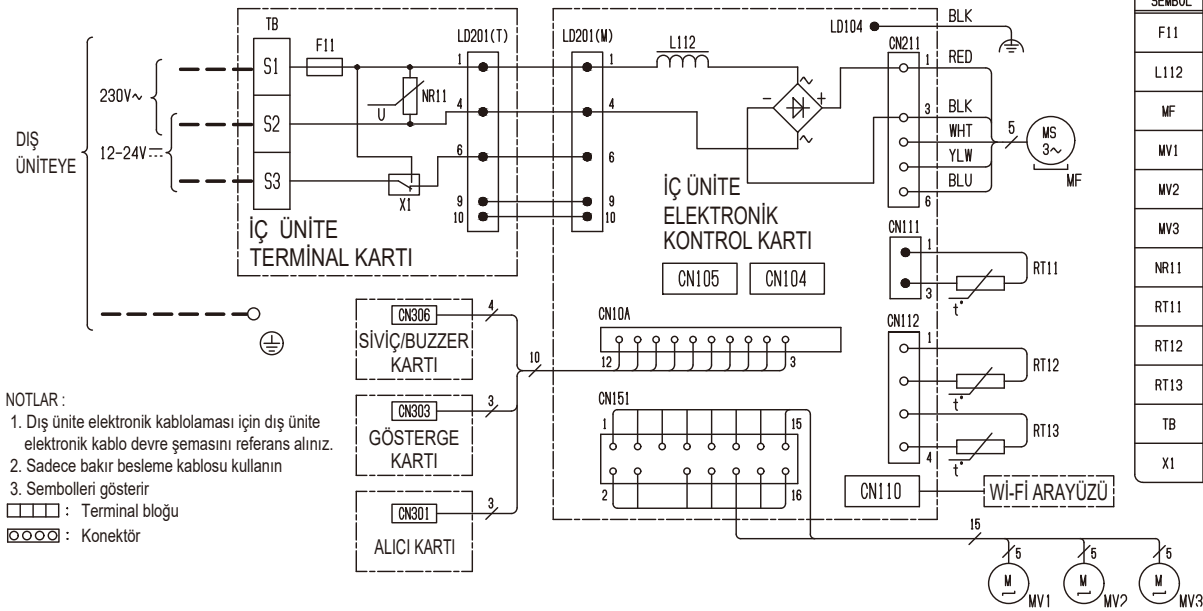

MSZ-FT25VG MSZ-FT35VG MSZ-FT50VG
 MSZ-FT25VGK MSZ-FT35VGK MSZ-FT50VGK

Unit: mm

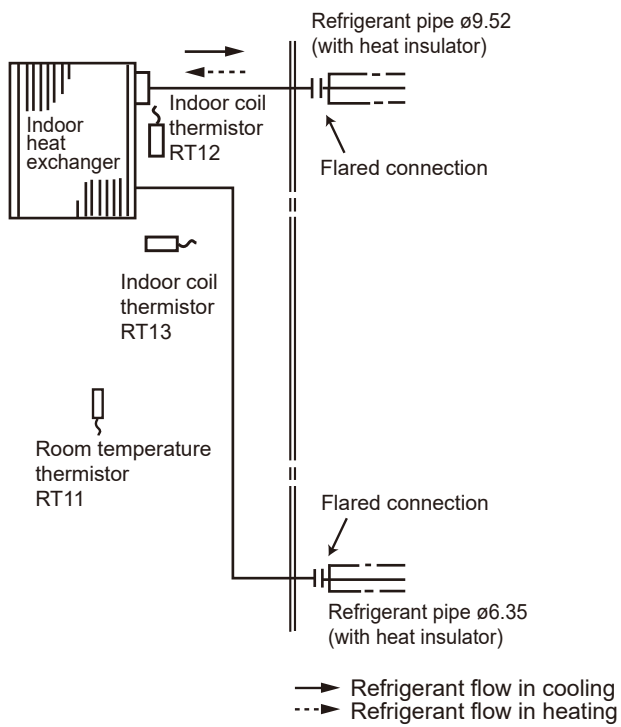

MSZ-FT25VG MSZ-FT35VG MSZ-FT50VG MSZ-FT25VGK MSZ-FT35VGK MSZ-FT50VGK

8-1. TIMER SHORT MODE

For service, the following set time can be shortened by bridging the timer short mode point on the electronic control P.C. board. (Refer to 10-7.)

- The set time for the ON/OFF timer can be reduced to 1 second for each minute.
- After the breaker is turned on, the time for starting the compressor, which normally takes 3 minutes, can be reduced to 1 minute. Restarting the compressor, which takes 3 minutes, cannot be reduced.

8-2. HOW TO SET REMOTE CONTROLLER EXCLUSIVELY FOR A PARTICULAR INDOOR UNIT

A maximum of 4 indoor units with wireless remote controllers can be used in a room.

To operate the indoor units individually with each remote controller, assign a number to each remote controller according to the number of the indoor unit.

This setting can be set only when all the following conditions are met:

- The remote controller is powered OFF.
- Weekly timer is not set.
- Weekly timer is not being edited.

(1) Hold down **[1~4]** button on the remote controller for 2 seconds to enter the pairing mode.

(2) Press **[1~4]** button again and assign a number to each remote controller.

Each press of **[1~4]** button advances the number in the following order: 1 → 2 → 3 → 4.

(3) Press **[EDIT/SEND SET]** button to complete the pairing setting.

8-3. AUTO RESTART FUNCTION

When the indoor unit is controlled with the remote controller, the operation mode, the set temperature, and the fan speed are memorized by the indoor electronic control P.C. board. "AUTO RESTART FUNCTION" automatically starts operation in the same mode just before the shutoff of the main power.

Operation

- ① If the main power has been cut, the operation settings remain.
- ② After the power is restored, the unit restarts automatically according to the memory.
(However, it takes at least 3 minutes for the compressor to start running.)

How to disable "AUTO RESTART FUNCTION"

- ① Turn off the main power for the unit.
- ② Cut the jumper wire to JR77 on the indoor electronic control P.C. board. (Refer to 10-7.)

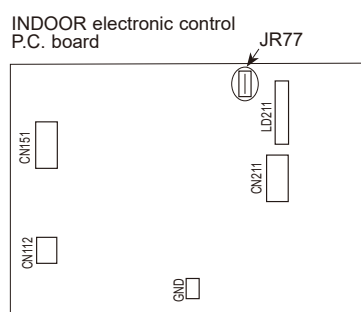

NOTE:

- The operation settings are memorized when 10 seconds have passed after the indoor unit was operated with the remote controller.
- If main power is turned OFF or a power failure occurs while AUTO START/STOP timer is active, the timer setting is cancelled.
- If the unit has been turned OFF with the remote controller before power failure, the auto restart function does not work as the power button of the remote controller is OFF.
- To prevent the breaker from tripping OFF due to the rush of starting current, systematize other home appliance not to turn ON at the same time.
- When some air conditioners are connected to the same supply system, if they are operated before power failure, the starting current of all the compressors may flow simultaneously at restart.
Therefore, the special counter-measures are required to prevent the main voltage-drop or the rush of the starting current by adding to the system that allows the units to start one by one.

8-4. Wi-Fi INTERFACE SETTING UP (MSZ-FT-VGK)

This Wi-Fi interface communicates the status information and controls the commands from the MELCloud by connecting to an indoor unit.

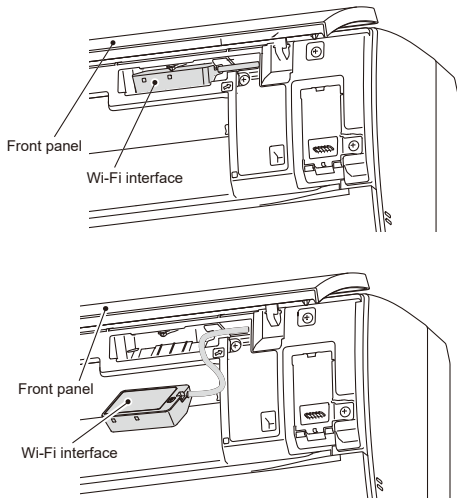

- (1) Open the front panel and remove the Wi-Fi interface.
- (2) Set up a connection between the Wi-Fi interface and the router.
Refer to the SETUP MANUAL and SETUP QUICK REFERENCE GUIDE provided with the unit.

For SETUP MANUAL, please go to the website below.
<http://www.melcloud.com/Support>

- (3) Put the Wi-Fi interface back and close the front panel after the setup is completed.
- (4) For MELCloud User Manual, please go to the website below.
<http://www.melcloud.com/Support>

NOTE:

- Ensure that the Router supports the WPA2-AES encryption setting before starting the Wi-Fi interface setup.
- The End user should read and accept the terms and conditions of the Wi-Fi service before using this Wi-Fi interface.
- To complete connection of this Wi-Fi interface to the Wi-Fi service, the Router may be required.
- This Wi-Fi interface will not commence transmission of any operational data from the system until the End user registers and accepts the terms and conditions of the Wi-Fi service.
- This Wi-Fi interface should not be installed and connected to any Mitsubishi Electric system which is to provide application critical cooling or heating.
- At the time of relocation or disposal, reset the Wi-Fi interface to the factory default.

Wi-Fi interface introduction

No.	Item	Description
1	MODE switch	It selects modes.
2	RESET switch	It resets the system and ALL settings.
3	ERR LED (Orange)	It shows the network error state.
4	NET LED (Green)	It shows the network state.
5	MODE LED (Orange)	It shows the Access point mode state.
6	UNIT LED (Green)	It shows the indoor unit state.

Mitsubishi Electric's Wi-Fi interface is designed for communication to Mitsubishi Electric's MELCloud Wi-Fi service.
Third party Wi-Fi interfaces cannot be connected to MELCloud.
Mitsubishi Electric is not responsible for any (i) under performance of a system or any product; (ii) system or product fault; or (iii) loss or damage to any system or product; which is caused by or arises from connection to and/or use of any third party Wi-Fi interface or any third party Wi-Fi service with Mitsubishi Electric equipment.

For the latest information regarding MELCloud from Mitsubishi Electric Corporation, please visit www.MELCloud.com.

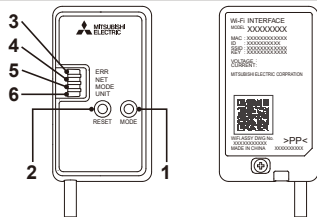

- (1) MODE switch
 - The MODE switch is used for selecting modes in configurations.
- (2) RESET switch
 - Hold down the RESET switch for 2 seconds to reboot the system.
 - Hold down the RESET switch for 14 seconds to initialize the Wi-Fi interface to the factory default.

NOTE:

When the Wi-Fi interface is reset to the factory default, ALL the configuration information will be lost. Take great care in implementing this operation.

8-5. CHANGING THE CORRECTION VALUE OF THE ROOM TEMPERATURE

Cut the jumper wire JR24 when the room temperature does not reach the set temperature during heating operation. (Refer to 10-7.)

Cutting the jumper wire JR24 changes the correction value of the room temperature during heating operation from -2°C to -5°C and lets the AUTO fan speed of the indoor unit and the compressor frequency increase easily.

INDOOR electronic control
P.C. board

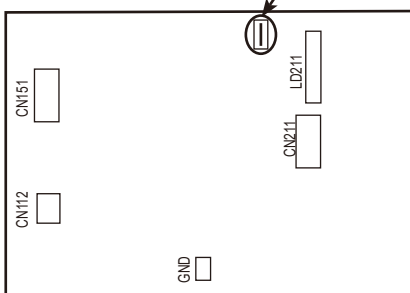

MSZ-FT25VG MSZ-FT35VG MSZ-FT50VG
MSZ-FT25VGK MSZ-FT35VGK MSZ-FT50VGK

WIRELESS REMOTE CONTROLLER

- | | | |
|-------------------------|--------------------------|---------------------------|
| MSZ-FT25VG- [E1] | MSZ-FT25VGK- [E1] | MSZ-FT25VGK- [ET1] |
| MSZ-FT35VG- [E1] | MSZ-FT35VGK- [E1] | MSZ-FT35VGK- [ET1] |
| MSZ-FT50VG- [E1] | MSZ-FT50VGK- [E1] | MSZ-FT50VGK- [ET1] |

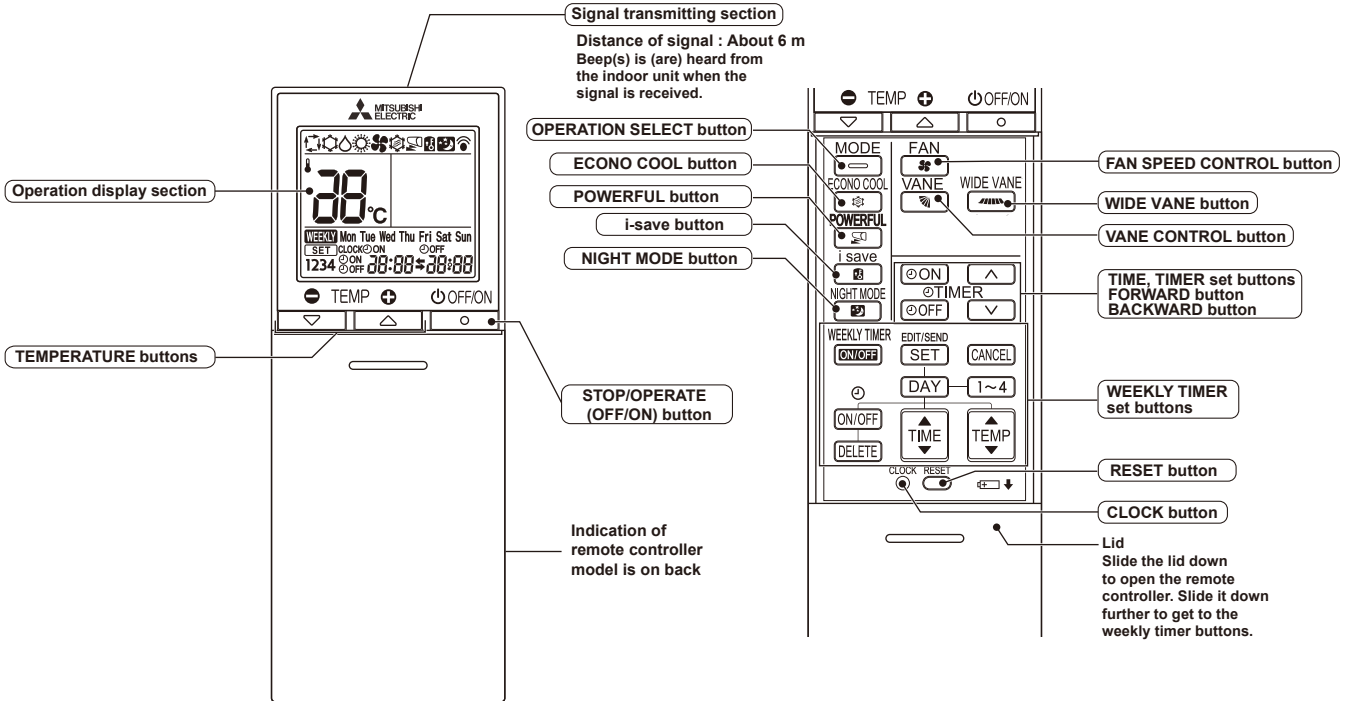

- MSZ-FT25VGK-** [SC1]
MSZ-FT35VGK- [SC1]
MSZ-FT50VGK- [SC1]

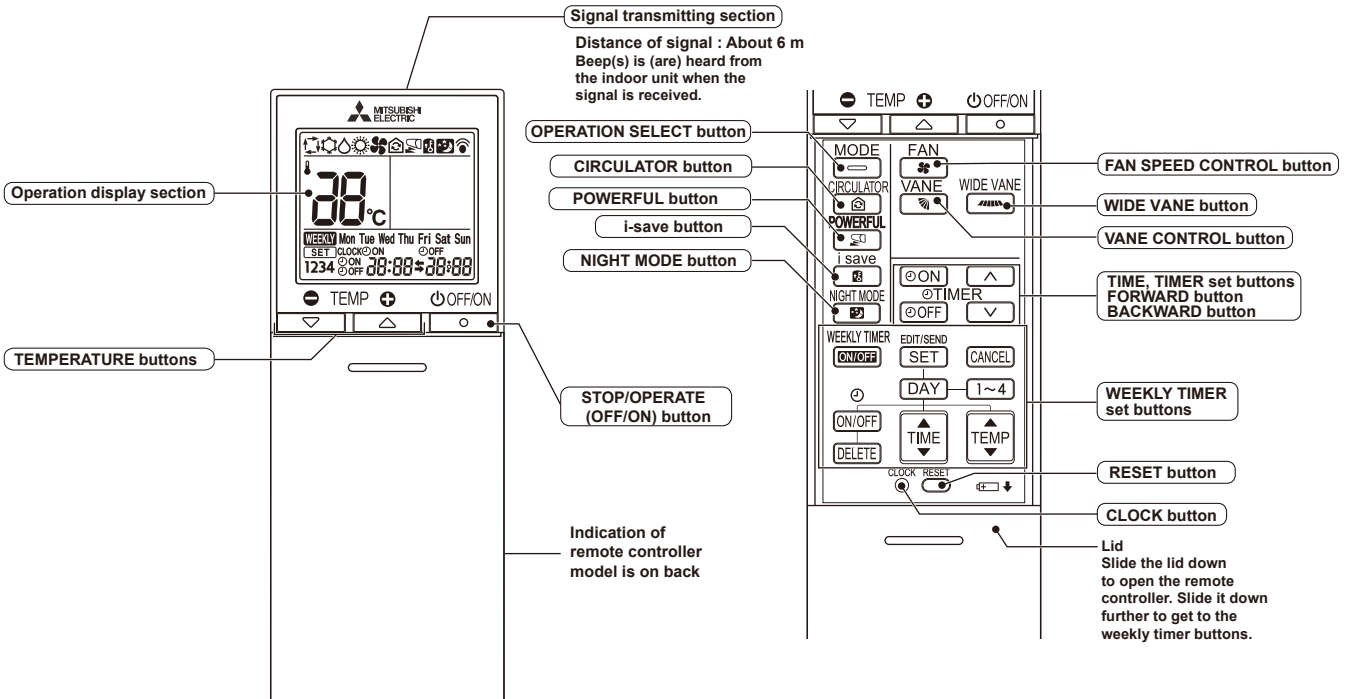







NOTE: Last setting will be stored after the unit is turned OFF with the remote controller. Indoor unit receives the signal of the remote controller with beeps.

INDOOR UNIT DISPLAY SECTION

Operation Indicator lamp

The operation indicator at the right side of the indoor unit indicates the operation state.

- The following indication applies regardless of shape of the indication.

Indication	Operation state	Room temperature
 	The unit is operating to reach the set temperature	About 2°C or more away from set temperature
 	The room temperature is approaching the set temperature	About 1 to 2°C from set temperature
 	Standby mode (Only during multi system operation)	—

-  Lit
-  Blinking
-  Not lit

9-1. COOL (❄️) OPERATION

- (1) Press STOP/OPERATE (OFF/ON) button.

OPERATION INDICATOR lamp of the indoor unit turns on with a beep tone.

- (2) Select COOL mode with OPERATION SELECT button.

- (3) Press TEMPERATURE buttons TEMP \ominus or \oplus button to select the desired temperature. The setting range is 16 - 31°C.

1. Coil frost prevention

The compressor operational frequency is controlled by the temperature of the indoor heat exchanger to prevent the coil from frosting.

When the temperature of indoor heat exchanger becomes too low, the coil frost prevention mode works.

The indoor fan operates at the set speed and the compressor stops. This mode continues until the temperature of indoor heat exchanger rises.

2. Low outside temperature operation

When the outside temperature is lower, low outside temperature operation starts, and the outdoor fan slows or stops.

3. Indoor fan speed control

When the thermostat turns OFF, the indoor fan operates very Low to reduce power consumption.

When the room temperature rises and the thermostat is ON, the indoor fan operates according to the settings on the remote controller.

9-2. DRY (☀️) OPERATION

- (1) Press STOP/OPERATE (OFF/ON) button.

OPERATION INDICATOR lamp of the indoor unit turns on with a beep tone.

- (2) Select DRY mode with OPERATION SELECT button.

- (3) The set temperature is determined from the initial room temperature.

1. Coil frost prevention

Coil frost prevention works the same way as that in COOL mode. (9-1.1.)

2. Low outside temperature operation

Low outside temperature operation works the same way as that in COOL mode. (9-1.2.)

3. Indoor fan speed control

Indoor fan speed control works the same way as that in COOL mode. (9-1.3.)

9-3. FAN (🌀) OPERATION

- (1) OPERATION INDICATOR lamp of the indoor unit turns on with a beep tone.

- (2) Select FAN mode with OPERATION SELECT button.

- (3) Select the desired fan speed. When AUTO, it becomes Low.

Only indoor fan operates.

Outdoor unit does not operate.

9-4. HEAT (🔥) OPERATION

- (1) Press STOP/OPERATE (OFF/ON) button.

OPERATION INDICATOR lamp of the indoor unit turns on with a beep tone.

- (2) Select HEAT mode with OPERATION SELECT button.

- (3) Press TEMPERATURE buttons TEMP \ominus or \oplus button to select the desired temperature. The setting range is 10 - 31°C.

1. Cold air prevention control

When the compressor is not operating or is starting, and the temperature of indoor heat exchanger and/or the room temperature is low or when defrosting is being done, the indoor fan will stop or rotate in Very Low speed.

2. High pressure protection

The compressor operational frequency is controlled by the temperature of the indoor heat exchanger to prevent the condensing pressure from increasing excessively.

When the temperature of indoor heat exchanger becomes too high, the high pressure protection works.

The indoor fan operates following the cold air prevention control. This mode continues until the temperature of indoor heat exchanger falls.

3. Defrosting

Defrosting starts when the temperature of outdoor heat exchanger becomes too low.

The compressor stops once, the indoor/outdoor fans stop, the 4-way valve reverses, and the compressor re-starts.

This mode continues until the temperature of outdoor heat exchanger rises or the fixed time passes.

9-5. AUTO CHANGE OVER ... AUTO MODE OPERATION

Once desired temperature is set, unit operation is switched automatically between COOL and HEAT operation.

Mode selection

(1) Initial mode

When unit starts the operation with AUTO operation from OFF:

- If the room temperature is higher than the set temperature, operation starts in COOL mode.
- If the room temperature is equal to or lower than the set temperature, operation starts in HEAT mode.

(2) Mode change

COOL mode changes to HEAT mode when about 15 minutes have passed with the room temperature 1°C below the set temperature.

HEAT mode changes to COOL mode when about 15 minutes have passed with the room temperature 1°C above the set temperature.

NOTE 1:

If 2 or more indoor units are operating in multi system, there might be a case that the indoor unit, which is operating in

□ (AUTO), cannot change over to the other operating mode (COOL ↔ HEAT) and becomes a state of standby.

Refer to **NOTE 2 "FOR MULTI SYSTEM AIR CONDITIONER"**.

NOTE 2

FOR MULTI SYSTEM AIR CONDITIONER

OUTDOOR UNIT: MXZ series

Multi system air conditioner can connect 2 or more indoor units with 1 outdoor unit.

- When you try to operate 2 or more indoor units with 1 outdoor unit simultaneously, one for the cooling and the others for heating, the operation mode of the indoor unit that operates first is selected. Other indoor units cannot operate, and operation indicator lamp blinks as shown in the figure below. In this case, please set all the indoor units to the same operation mode.

OPERATION INDICATOR



● Lit



○ Blinking

○ Not lit

- When indoor unit starts the operation during defrosting of outdoor unit, it takes a few minutes (max. 10 minutes) to blow out warm air.
- In the heating operation, though indoor unit is not operating, it may get warm or the sound of refrigerant flow may be heard. It is not malfunction. The reason is that the refrigerant continuously flows into it.

9-6. AUTO VANE OPERATION

1. Horizontal vane

(1) Vane motor drive

These models are equipped with a stepping motor for the horizontal vane. The rotating direction, speed, and angle of the motor are controlled by pulse signals (approximately 12 V) transmitted from indoor microprocessor.

(2) The horizontal vane angle and mode change as follows by pressing VANE control button.

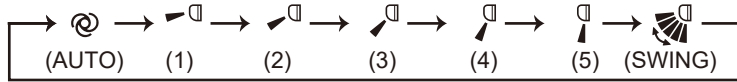

(3) Positioning

To confirm the standard position, the vane moves until it touches the vane stopper. Then the vane is set to the selected angle.

Confirmation of standard position is performed in the following cases:

- When the operation starts or finishes (including timer operation).
- When the test run starts.
- When standby mode (only during multi system operation) starts or finishes.

(4) VANE AUTO (@) mode

In VANE AUTO mode, the microprocessor automatically determines the vane angle to make the optimum room temperature distribution.

In COOL and DRY operation

Vane angle is fixed to Horizontal position.

In HEAT operation

Vane angle is fixed to Downward position.

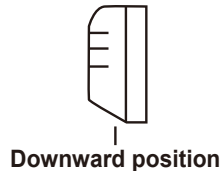

(5) STOP (operation OFF) and ON TIMER standby

In the following cases, the horizontal vane returns to the closed position.

- When OFF/ON (stop/operate) button is pressed (POWER OFF).
- When the operation is stopped by the emergency operation.
- When ON TIMER is ON standby.

(6) Dew prevention

If the lower position is selected during COOL/DRY, the vane automatically moves to the upward position after 0.5 to 1 hour to prevent any condensation from dripping.

(7) SWING () mode

By selecting SWING mode with VANE control button, the horizontal vane swings vertically.

(8) ECONO COOL () operation (ECONOMical operation)

When ECONO COOL button is pressed in COOL mode, set temperature and the air flow direction is automatically changed by the microprocessor. However, the temperature on the LCD screen on the remote controller is not changed. Also the horizontal vane swings in various cycle.

SWING operation makes you feel cooler than set temperature. So, even though the set temperature is higher, the air conditioner can keep comfort. As a result, energy can be saved.

To cancel this operation, select a different mode or press one of the following buttons in ECONO COOL operation: ECONO COOL, VANE control or POWERFUL button.

(10) POWERFUL () operation

The air conditioner automatically adjusts the fan speed and the set temperature, and operates the POWERFUL mode. The POWERFUL mode is cancelled automatically 15 minutes after operation starts, or when POWERFUL button is pressed once again within 15 minutes after operation starts. The operation mode returns to the mode prior to POWERFUL operation. To cancel this operation manually, select a different mode or press one of the following buttons within 15 minutes after operation starts: STOP/OPERATE (OFF/ON), ECONO COOL, FAN SPEED CONTROL, CIRCULATOR, or i-save button.

2. Vertical vane

(1) Vane motor drive

These models are equipped with a stepping motor for the vertical vane. The rotating direction, speed, and angle of the motor are controlled by pulse signals (approximately 12 V) transmitted from microprocessor.

(2) The vertical vane angle and mode change as follows by pressing WIDE VANE CONTROL button.

(3) Positioning



To confirm the standard position, the vane moves until it touches the vane stopper. Then the vane is set to the selected angle.

Confirmation of standard position is performed in the following cases:

(a) STOP/OPERATE (OFF/ON) button is pressed (POWER ON).

(4) SWING (SWING) MODE

By selecting SWING mode with WIDE VANE CONTROL button, the vertical vane swings horizontally. The remote controller displays "SWING". Swing mode is cancelled when WIDE MODE CONTROL button is pressed once again.

9-7. TIMER OPERATION

1. How to set the time

(1) Check that the current time is set correctly.

NOTE: Timer operation will not work without setting the current time. Initially "0:00" blinks at the current time display of TIME MONITOR, so set the current time correctly with CLOCK button.

How to set the current time

(a) Press the CLOCK button.

(b) Press the TIME SET buttons (▲) and (▼) to set the current time.

- Each time FORWARD button (▲) is pressed, the set time increases by 1 minute, and each time BACKWARD button (▼) is pressed, the set time decreases by 1 minute.
- Pressing those buttons longer, the set time increases/decreases by 10 minutes.

(c) Press the CLOCK set button.

(2) Press STOP/OPERATE (OFF/ON) button to start the air conditioner.

(3) Set the time of timer.

ON timer setting

(a) Press ON TIMER button (ON) during operation.

(b) Set the time of the timer using TIME SET buttons (▲) and (▼).*

OFF timer setting

(a) Press OFF TIMER button (OFF) during operation.

(b) Set the time of the timer using TIME SET buttons (▲) and (▼).*

*Each time FORWARD button (▲) is pressed, the set time increases by 10 minutes: each time BACKWARD button (▼) is pressed, the set time decreases by 10 minutes.

2. To release the timer

To release ON timer, press ON TIMER button (ON).

To release OFF timer, press OFF TIMER button (OFF).

TIMER is cancelled and the display of set time disappears.

PROGRAM TIMER

- OFF timer and ON timer can be used in combination. The set time that is reached first will operate first.
- “→” and “←” display shows the order of OFF timer and ON timer operation.

(Example 1) The current time is 8:00 PM.
The unit turns off at 11:00 PM, and on at 6:00 AM.

(Example 2) The current time is 11:00 AM.
The unit turns on at 5:00 PM, and off at 9:00 PM.

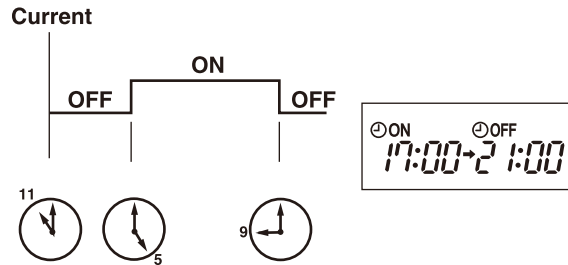
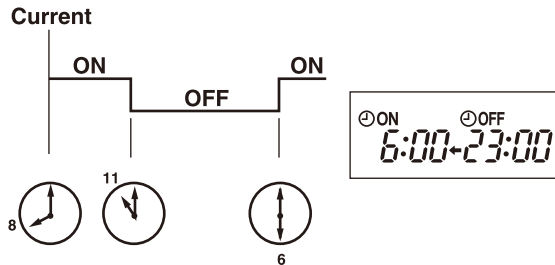

NOTE: If the main power is turned OFF or a power failure occurs while ON/OFF timer is active, the timer setting is cancelled. As these models are equipped with an auto restart function, the air conditioner starts operating with timer cancelled when power is restored.

9-8. WEEKLY TIMER OPERATION

- A maximum of 4 ON or OFF timers can be set for individual days of the week.
- A maximum of 28 ON or OFF timers can be set for a week.

E.g. : Runs at 24°C from waking up to leaving home, and runs at 27°C from getting home to going to bed on weekdays.
Runs at 27°C from waking up late to going to bed early on weekends.

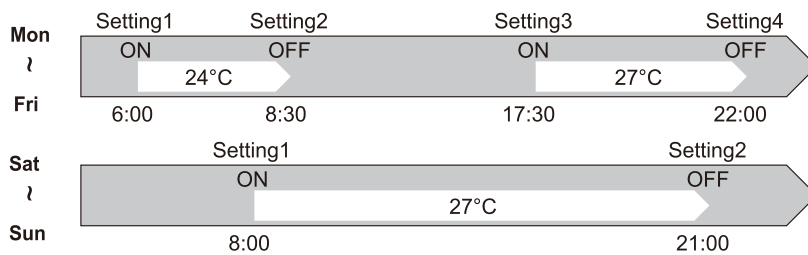

NOTE:

- The simple ON/OFF timer setting is available while the weekly timer is on. In this case, the ON/OFF timer has priority over the weekly timer; the weekly timer operation will start again after the simple ON/OFF timer is complete.

1. How to set the weekly timer

* Make sure that the current time and day are set correctly.

- (1) Press **EDIT/SEND** button to enter the weekly timer setting mode.

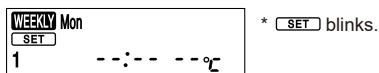

- (2) Press **DAY** and **1~4** buttons to select setting day and number.

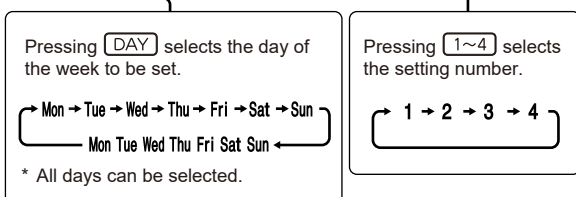
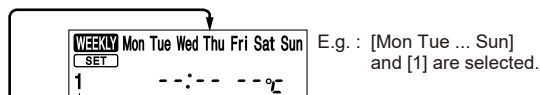

(3) Press , , and buttons to set ON/OFF, time, and temperature.

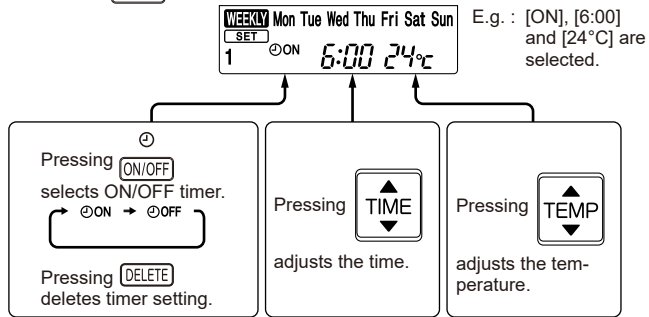

- * Hold down the button to change the time quickly.
- * The temperature can be set between 16°C and 31°C at COOL operation.
- * The temperature can be set between 10°C and 31°C at HEAT operation.

Press and buttons to continue setting the timer for other days and/or numbers.

(4) Press button to complete and transmit the weekly timer setting.



NOTE:

- Press button to transmit the setting information of weekly timer to the indoor unit. Point the remote controller toward the indoor unit for 3 seconds.
- When setting the timer for more than one day of the week or one number, button does not have to be pressed per each setting. Press button once after all the settings are completed. All the weekly timer settings will be saved.
- Press button to enter the weekly timer setting mode, and press and hold button for 5 seconds to erase all weekly timer settings. Point the remote controller toward the indoor unit.

(5) Press button to turn the weekly timer ON. (lights.)

•When the weekly timer is ON, the day of the week whose timer setting is completed, will light.

Press button again to turn the weekly timer OFF. (goes out.)

NOTE:

The saved settings will not be cleared when the weekly timer is turned OFF.

2. Checking weekly timer setting

(1) Press button to enter the weekly timer setting mode.

* blinks.

(2) Press or buttons to view the setting of the particular day or number.

(3) Press button to exit the weekly timer setting.

NOTE:

When all days of the week are selected to view the settings and a different setting is included among them, will be displayed.

9-9. NIGHT MODE (🌙) OPERATION

NIGHT MODE changes the brightness of the operation indicator, disables the beep sound and limits the noise level of the outdoor unit.

- (1) Press NIGHT MODE button during operation to activate NIGHT mode (🌙).
 - The operation indicator lamp dims.
 - The beep sound will be disabled except that emitted when the operation is started or stopped.
 - Noise level of the outdoor unit will be lower than that mentioned in SPECIFICATIONS.(Except the connection to MXZ.)
- (2) Press NIGHT MODE button to cancel NIGHT mode (🌙).

NOTE:

- Noise level of the outdoor unit may not change after startup of the unit, during the protection operation, or depending on other operating conditions.
- The fan speed of the indoor unit will not change.
- The operation indicator lamp will be hard to be seen in a bright room.
- Operating POWERFUL operation during NIGHT mode will increase the noise level of the outdoor unit.
- Noise level of the outdoor unit will not decrease during Multi system operation.

9-10. i-save (🌞) OPERATION

1. How to set i-save operation

- (1) Press STOP/OPERATE (OFF/ON) button.
- (2) Select COOL, CIRCULATOR, HEAT, ECONO COOL, or NIGHT mode.
- (3) Press i-save button.
- (4) Set the temperature, fan speed, and airflow direction for i-save operation.

NOTE:

- i-save operation cannot be selected during DRY, FAN or AUTO mode operation.
- The setting range of HEAT mode i-save operation is 10 - 31°C.
- 2 groups of setting can be saved. (One for COOL/ECONO COOL/CIRCULATOR, one for HEAT)

2. How to cancel operation

- Press i-save button again.
 - i-save operation can also be cancelled by pressing POWERFUL button or OPERATION SELECT button to change the operation mode.
- The same setting is select from the next time by simply pressing i-save button.

9-11. CIRCULATOR OPERATION

In case the indoor temperature reaches the setting temperature, the outdoor unit stops and the indoor unit starts FAN operation to circulate the indoor air.

The setting of fan speed and airflow direction can be changed.

The outdoor unit starts operation automatically when the indoor temperature drops below the setting temperature.

- (1) Press CIRCULATOR button during HEAT mode to enable CIRCULATOR operation.

The unit performs FAN operation in case the indoor temperature reaches the setting temperature.
- (2) Set the fan speed and airflow direction.
 - The setting of fan speed and airflow direction is common for HEAT and CIRCULATOR operation.
 - Ventilation starts at Low fan speed in case AUTO fan speed is selected.
- (3) Press CIRCULATOR button again to cancel CIRCULATOR operation.

NOTE:

1. FAN operation may make you feel cold wind.

Reduce the FAN speed or adjust the airflow direction to avoid the wind.
2. CIRCULATOR operation doesn't work in the following situation.
 - AUTO mode (Auto change over) is selected.
 - Defrosting is being done.
 - Indoor unit is connected to multi type outdoor unit.

Although received sound is heard from the indoor unit and mark is displayed on remote controller when the button is pushed, CIRCULATOR operation will not work in multi connection.

9-12. EMERGENCY/TEST OPERATION

In the case of test run operation or emergency operation, use EMERGENCY OPERATION switch in the right side of the indoor unit. Emergency operation is available when the remote controller is missing or has failed, or when the batteries in the remote controller are running down. The unit will start and OPERATION INDICATOR lamp will light up.

The first 30 minutes of operation is the test run operation. This operation is for servicing. The indoor fan runs at High speed and the temperature control does not work.

After 30 minutes of test run operation, the system shifts to EMERGENCY COOL/HEAT MODE with a set temperature of 24°C. The fan speed shifts to Medium. The coil frost prevention works even in the test run or the emergency operation. In the test run or emergency operation, the horizontal vane operates in VANE AUTO (@) mode.

Emergency operation continues until EMERGENCY OPERATION switch is pressed once or twice or the unit receives any signal from the remote controller. In the latter case, normal operation will start.

NOTE: Do not press EMERGENCY OPERATION switch during normal operation.

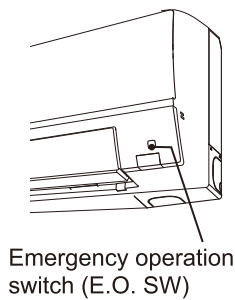

Operation mode	COOL/HEAT
Set temperature	24°C
Fan speed	Med.
Horizontal vane	Auto

The operation mode is indicated by the Operation Indicator lamp as following

Operation Indicator lamp

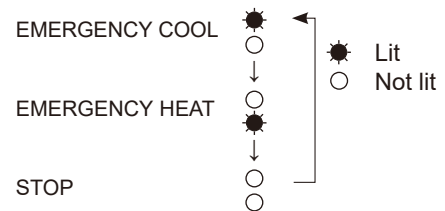

9-13. 3-MINUTE TIME DELAY OPERATION

When the system turns OFF, compressor will not restart for 3 minutes as 3-minute time delay function operates to protect compressor from overload.

MSZ-FT25VG MSZ-FT35VG MSZ-FT50VG
MSZ-FT25VGK MSZ-FT35VGK MSZ-FT50VGK

10-1. CAUTIONS ON TROUBLESHOOTING

1. Before troubleshooting, check the following

- 1) Check the power supply voltage.
- 2) Check the indoor/outdoor connecting wire for miswiring.

2. Take care of the following during servicing

- 1) Before servicing the air conditioner, be sure to turn OFF the main unit first with the remote controller, and after confirming the horizontal vane is closed, turn OFF the breaker and/or disconnect the power plug.
- 2) Be sure to turn OFF the power supply before removing the front panel, the cabinet, the top panel, and the P.C. board.
- 3) When removing the P.C. board, hold the edge of the board with care NOT to apply stress on the components.
- 4) When connecting or disconnecting the connectors, hold the connector housing. DO NOT pull the lead wires.

<Incorrect>



Lead wiring

<Correct>



Connector housing

3. Troubleshooting procedure

- 1) Check if the OPERATION INDICATOR lamp on the indoor unit is blinking ON and OFF to indicate an abnormality. To make sure, check how many times the OPERATION INDICATOR lamp is blinking ON and OFF before starting service work.
- 2) Before servicing, check that the connector and terminal are connected properly.
- 3) When the electric control P.C. board seems to be defective, check the copper foil pattern for disconnection and the components for bursting and discoloration.
- 4) When troubleshooting, Refer to 10-2, 10-3 and 10-4.

4. How to replace batteries

Weak batteries may cause the remote controller malfunction.

In this case, replace the batteries to operate the remote controller normally.

- ① Remove the front lid and insert batteries. Then reattach the front lid.

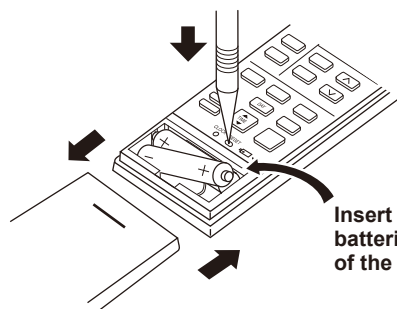

Insert the negative pole of the batteries first. Check if the polarity of the batteries is correct.

- ② Press RESET button with a thin instrument, and then use the remote controller.

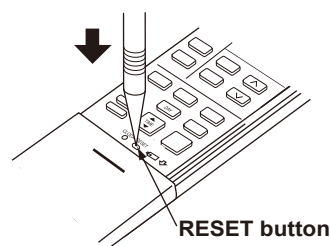

RESET button

NOTE: 1. If RESET button is not pressed, the remote controller may not operate correctly.

2. This remote controller has a circuit to automatically reset the microprocessor when batteries are replaced.

This function is equipped to prevent the microprocessor from malfunctioning due to the voltage drop caused by the battery replacement.

3. Do not use the leaking batteries.

10-2. FAILURE MODE RECALL FUNCTION

Outline of the function

This air conditioner can memorize the abnormal condition which has occurred once.

Even though LED indication listed on the troubleshooting check table (10-4.) disappears, the memorized failure details can be recalled.

1. Flow chart of failure mode recall function for the indoor/outdoor unit

Operational procedure

The cause of abnormality cannot be found because the abnormality does not recur.

Setting up the failure mode recall function

Turn ON the power supply.
 <Preparation of the remote controller>
 ① While pressing Operation select button and TEMP \oplus button on the remote controller at the same time, press RESET button.
 ② First, release RESET button.
 Hold down the other 2 buttons for another 3 seconds. Make sure that the indicators on the LCD screen shown in the right figure are all displayed. Then release the buttons.

FT25/35/50VG - [E1]

FT25/35/50VGK - [E1], [ET1] FT25/35/50VGK - [SC1]

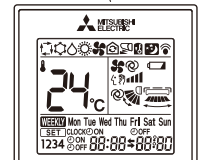
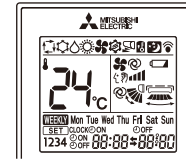
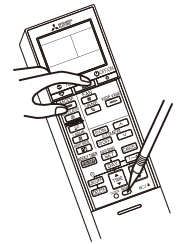
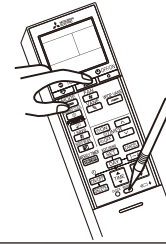

Press OFF/ON (stop/operate) button of the remote controller (the set temperature is displayed) with the remote controller headed towards the indoor unit. ※1

※1 Regardless of normal or abnormal condition, a short beep is emitted once the signal is received.

Does the upper lamp of OPERATION INDICATOR lamp on the indoor unit blink at the interval of 0.5 seconds?
 Blinks: Either indoor or outdoor unit is abnormal.
 Beep is emitted at the same timing as the blinking of the upper lamp of OPERATION INDICATOR lamp. ※2

Indoor unit is normal.
 But the outdoor unit might be abnormal because there are some abnormalities that can not be recalled with this way.
 Check if outdoor unit is abnormal according to the detailed outdoor unit failure mode recall function.

NOTE: It takes up to 1 minute to indicate the outdoor unit abnormality. Even if the OPERATION INDICATOR lamp is not lighting, keep checking at least 1 minute or longer.

Judgment of indoor/outdoor abnormality

Before blinking, does the upper lamp of OPERATION INDICATOR lamp stay ON for 3 seconds?
 Stays ON for 3 seconds (without beep):
 The outdoor unit is abnormal.

The outdoor unit is abnormal.
 Check the blinking pattern, and identify the abnormal point by referring to the table of outdoor unit failure mode recall function. (Refer to outdoor unit service manual.)
 Make sure to check at least 2 consecutive blinking cycles. ※3

The indoor unit is abnormal.
 Check the blinking pattern, and identify the abnormal point by referring to the table of indoor unit failure mode recall function. (Refer to 10-2.2)
 Make sure to check at least 2 consecutive blinking cycles. ※2

Releasing the failure mode recall function

Release the failure mode recall function by the following procedures.
 Turn OFF the power supply and turn it ON again.
 Press RESET button of the remote controller.

Repair the failure parts.

Deleting the memorized abnormal condition

① After repairing the unit, recall the failure mode again according to "Setting up the failure mode recall function" mentioned above.
 ② Press OFF/ON (stop/operate) button of the remote controller (the set temperature is displayed) with the remote controller headed towards the indoor unit.
 ③ Press EMERGENCY OPERATION switch so that the memorized abnormal condition is deleted.
 ④ Release the failure mode recall function according to "Releasing the failure mode recall function" mentioned above.

NOTE: 1. Make sure to release the failure mode recall function after it is set up, otherwise the unit cannot operate properly.
 2. If the abnormal condition is not deleted from the memory, the last abnormal condition is kept memorized.

※2. Blinking pattern when the indoor unit is abnormal:

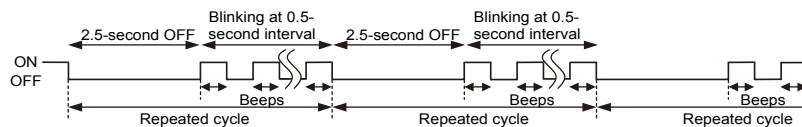

※3. Blinking pattern when the outdoor unit is abnormal:

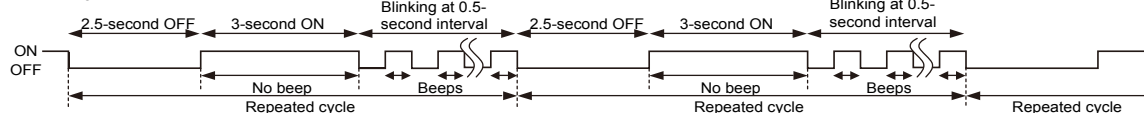



2. Table of indoor unit failure mode recall function

Upper lamp of OPERATION INDICATOR lamp	Abnormal point (Failure mode)	Condition	Remedy
Not lit	Normal	—	—
1-time blink every 0.5-second	Room temperature thermistor	The room temperature thermistor short or open circuit is detected every 8 seconds during operation.	Refer to the characteristics of the room temperature thermistor (10-7.).
2-time blink 2.5-second OFF	Indoor coil thermistor	The indoor coil thermistor short or open circuit is detected every 8 seconds during operation.	Refer to the characteristics of the main indoor coil thermistor, the sub indoor coil thermistor (10-7.).
3-time blink 2.5-second OFF	Serial signal	The serial signal from outdoor unit is not received for a maximum of 6 minutes.	Refer to 10-6.Ⓒ "How to check miswiring and serial signal error".
11-time blink 2.5-second OFF	Indoor fan motor	The rotational frequency feedback signal is not emitted for the 12 seconds after the indoor fan is operated.	Refer to 10-6.Ⓐ "Check of indoor fan motor".
12-time blink 2.5-second OFF	Indoor control system	It cannot properly read data in the nonvolatile memory of the indoor electronic control P.C. board.	Replace the indoor electronic control P.C. board.

NOTE: Blinking patterns of this mode differ from the ones of TROUBLESHOOTING CHECK TABLE (10-4.).

10-3. INSTRUCTION OF TROUBLESHOOTING

1. Check of the unit.

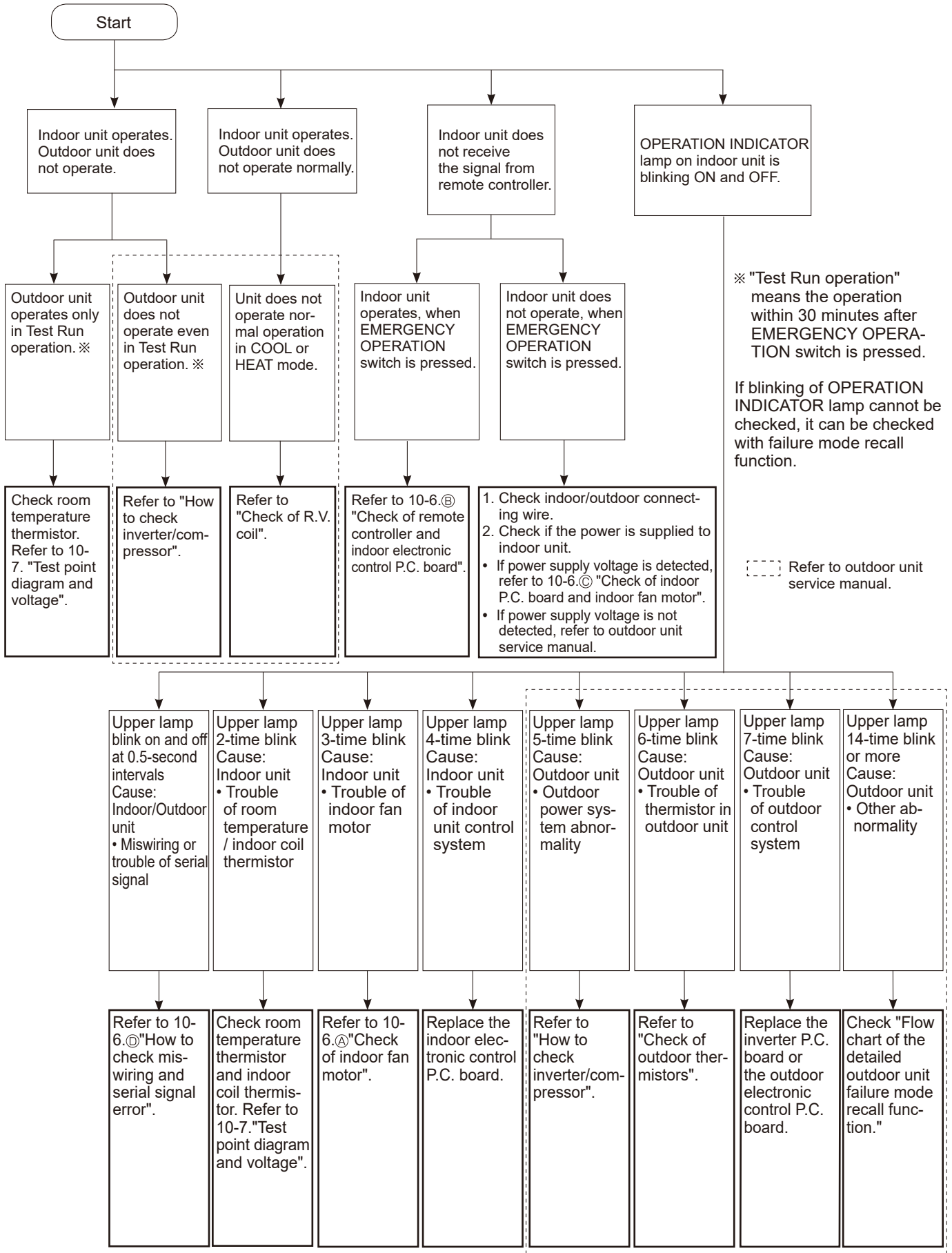

2. Check of Wi-Fi interface (MSZ-FT-VGK)

Follow the procedure below if the air conditioner cannot be monitored or controlled with a device such as a smartphone.

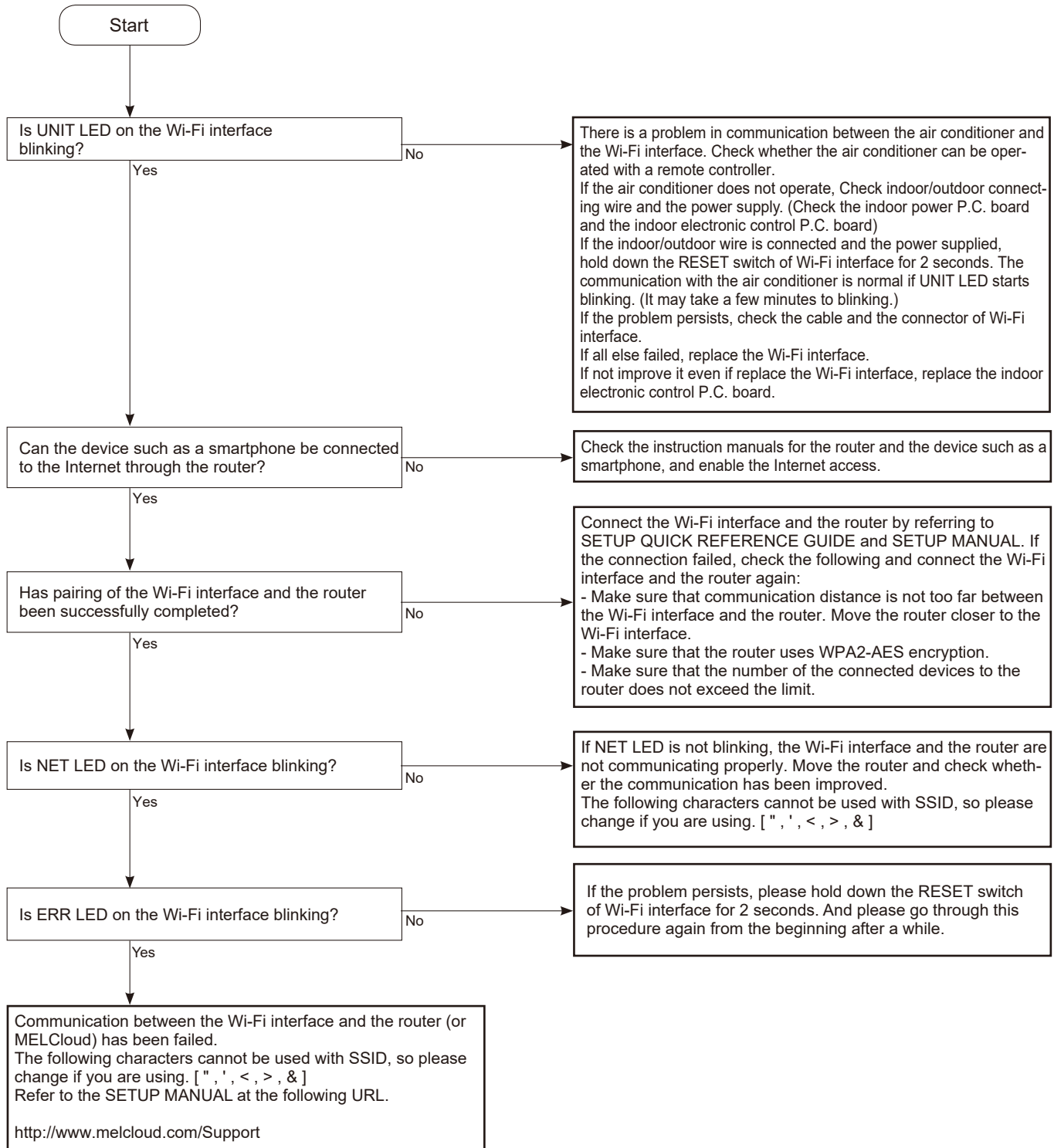



10-4. TROUBLESHOOTING CHECK TABLE





Before taking measures, make sure that the symptom reappears for accurate troubleshooting.

When the indoor unit has started operation and detected an abnormality of the following condition (the first detection after the power ON), the indoor fan motor turns OFF and OPERATION INDICATOR lamp blinks.

OPERATION INDICATOR

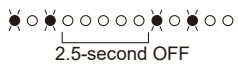

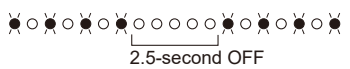
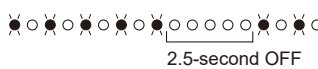
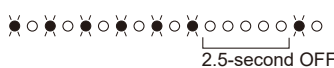
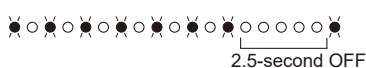
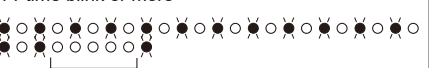
-  Lit
-  Blinking
-  Not lit

No.	Abnormal point	Operation indicator lamp	Symptom	Condition	Remedy
1	Miswiring or serial signal	Upper lamp blinks. 0.5-second ON  0.5-second OFF	Indoor unit and outdoor unit do not operate.	The serial signal from the outdoor unit is not received for 6 minutes.	• Refer to 10-6. ⑤ "How to check miswiring and serial signal error".
2	Indoor coil thermistor	Upper lamp blinks. 2-time blink  2.5-second OFF		The indoor coil or the room temperature thermistor is short or open circuit.	• Refer to the characteristics of indoor coil thermistor, and the room temperature thermistor (10-7.).
	Room temperature thermistor				
3	Indoor fan motor	Upper lamp blinks. 3-time blink  2.5-second OFF		The rotational frequency feedback signal is not emitted during the indoor fan operation.	• Refer to 10-6. ④ "Check of indoor fan motor".
4	Indoor control system	Upper lamp blinks. 4-time blink  2.5-second OFF		It cannot properly read data in the nonvolatile memory of the indoor electronic control P.C. board.	• Replace the indoor electronic control P.C. board.
5	Outdoor power system	Upper lamp blinks. 5-time blink  2.5-second OFF		It consecutively occurs 3 times that the compressor stops for overcurrent protection or start-up failure protection within 1 minute after start-up.	• Refer to "How to check of inverter/compressor". Refer to outdoor unit service manual • Check the stop valve.
6	Outdoor thermistors	Upper lamp blinks. 6-time blink  2.5-second OFF		The outdoor thermistors short or open circuit during the compressor operation.	• Refer to "Check of outdoor thermistor". Refer to outdoor unit service manual.
7	Outdoor control system	Upper lamp blinks. 7-time blink  2.5-second OFF		It cannot properly read data in the nonvolatile memory of the inverter P.C. board or the outdoor electronic control P.C. board.	• Replace the inverter P.C. board or the outdoor electronic control P.C. board. Refer to outdoor unit service manual.
8	Other abnormality	Upper lamp blinks. 14-time blink or more  2.5-second OFF		An abnormality other than above mentioned is detected.	• Check the stop valve. • Check the 4-way valve. • Confirm the abnormality in detail using the failure mode recall function for outdoor unit.
9	Outdoor control system	Upper lamp lights up. 	Outdoor unit does not operate	It cannot properly read data in the nonvolatile memory of the inverter P.C. board.	• Check the blinking pattern of the LED on the inverter P.C. board.

OPERATION INDICATOR



- Lit
- ◐ Blinking
- Not lit

No.	Abnormal point	Operation indicator lamp	Symptom	Condition	Remedy
1	MXZ type Operation mode setting	Upper lamp lights and lower lamp blinks. 2.5-second OFF	Outdoor unit operates but indoor unit does not operate.	The operation mode of the each indoor unit is differently set to COOL (includes DRY) and HEAT at the same time, the operation mode of the indoor unit that has operated at first has the priority.	<ul style="list-style-type: none"> • Unify the operation mode. Refer to outdoor unit service manual.

10-5. TROUBLE CRITERION OF MAIN PARTS

Part name	Check method and criterion	Figure
Room temperature thermistor (RT11) Indoor coil thermistor (RT12, RT13)	Measure the resistance with a tester. Refer to 10-7. "Test point diagram and voltage", "Indoor electronic control P.C. board", for the chart of thermistor.	
Indoor fan motor (MF)	Check 10-6.Ⓐ "Check of indoor fan motor".	
Vane motor (MV)	Measure the resistance between the terminals with a tester. (Temperature: 10 - 30°C)	

Color of the lead wire	Normal
RED-BLK	262 ~ 328 Ω

10-6. TROUBLESHOOTING FLOW

A Check of indoor fan motor

The indoor fan motor error has occurred, and the indoor fan does not operate.

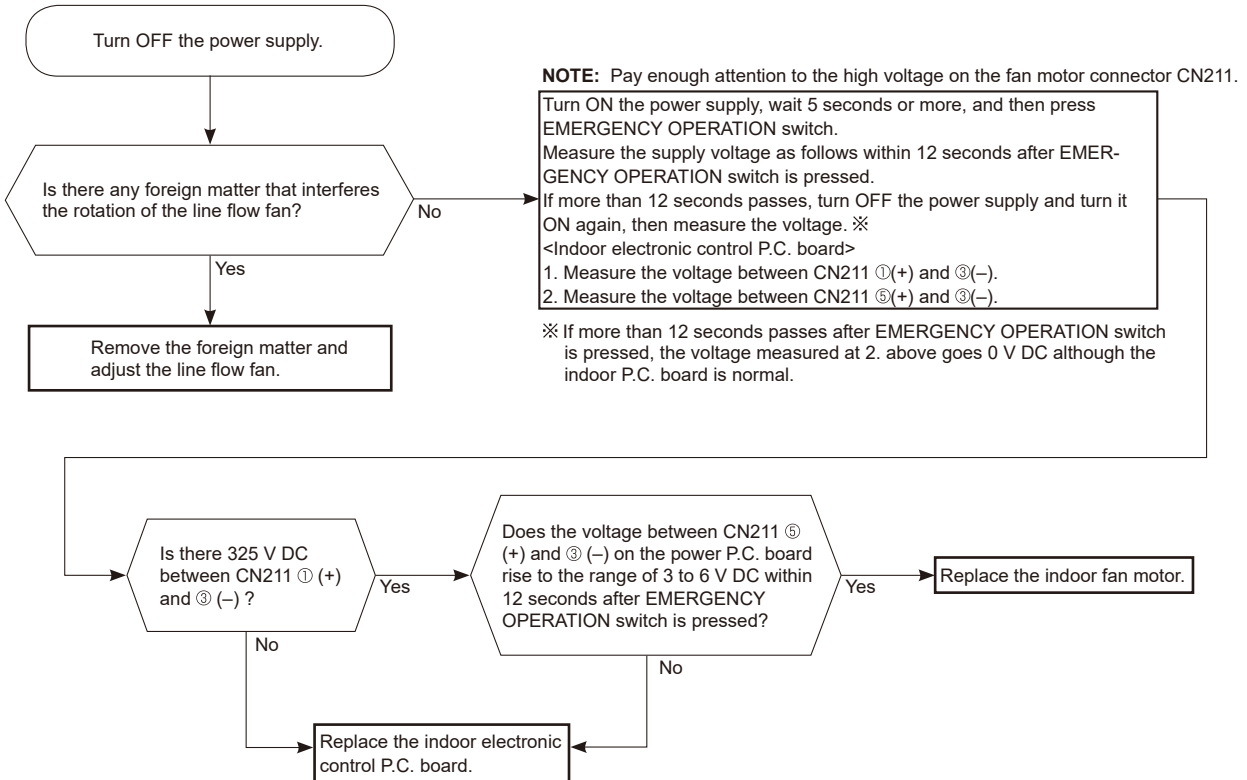

The indoor fan motor error has occurred, and the indoor fan repeats "12-second ON and 30-second OFF" 3 times, and then stops.

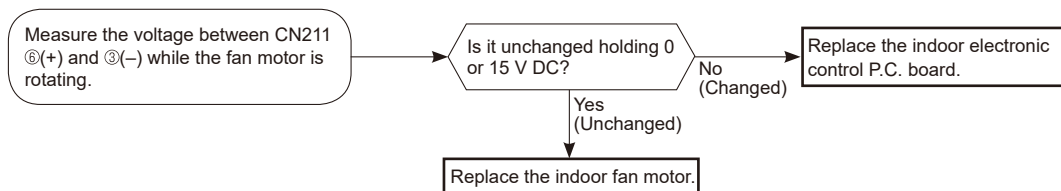

B Check of remote controller and indoor electronic control P.C. board

※Check if the remote controller is exclusive for this air conditioner.

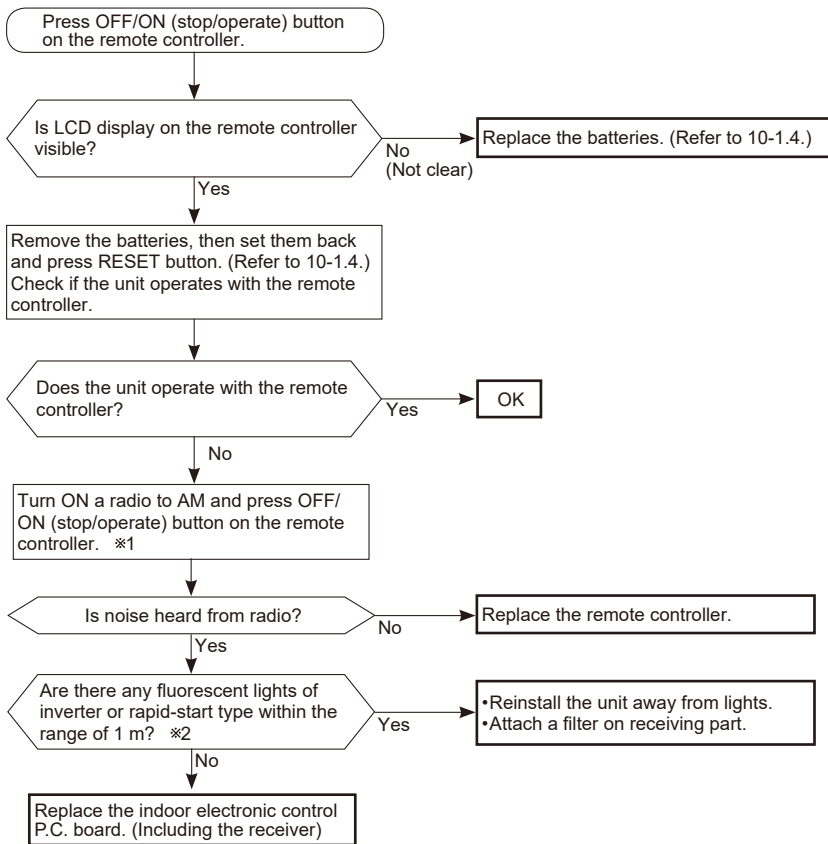

※ 1 Look at the image of the signal transmitting section of the remote controller through the monitor of a digital camera or a camera phone. It is normal if the LED of the signal transmitting section lights up when the OPERATE/STOP (ON/OFF) button on the remote controller is pressed. However, it may be difficult to see the illuminated LED of the signal transmitting section with a smartphone camera.

※ 2 If the inverter fluorescent light is turned on when the room is cool, the unit may have difficulty receiving the signal from the remote controller or may not be able to operate with it; if the inverter fluorescent light is turned on when the room is warm, the unit may be able to operate with the remote controller.

C Check of indoor P.C. board and indoor fan motor

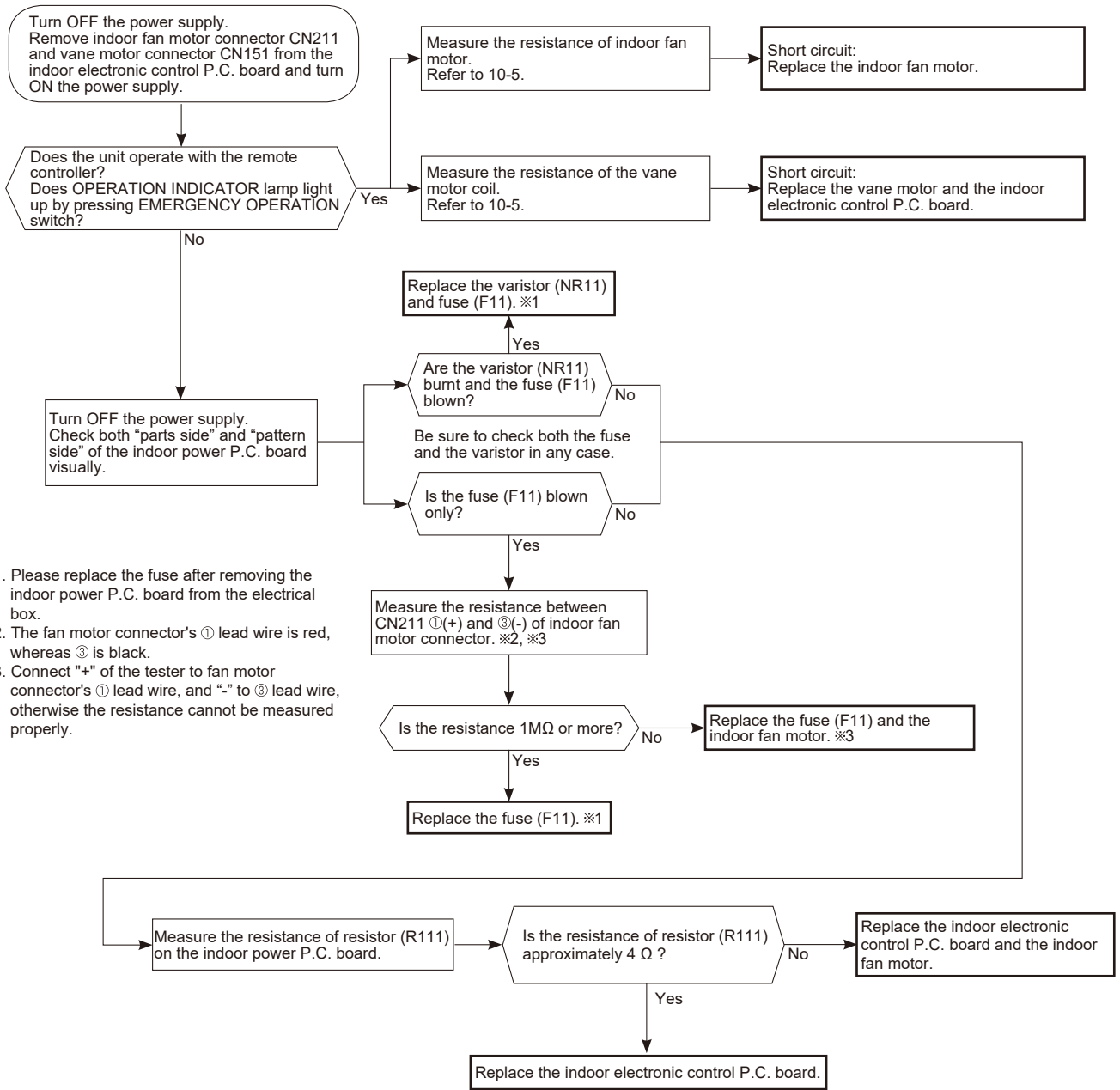

- ※1. Please replace the fuse after removing the indoor power P.C. board from the electrical box.
- ※2. The fan motor connector's ① lead wire is red, whereas ③ is black.
- ※3. Connect "+" of the tester to fan motor connector's ① lead wire, and "-" to ③ lead wire, otherwise the resistance cannot be measured properly.

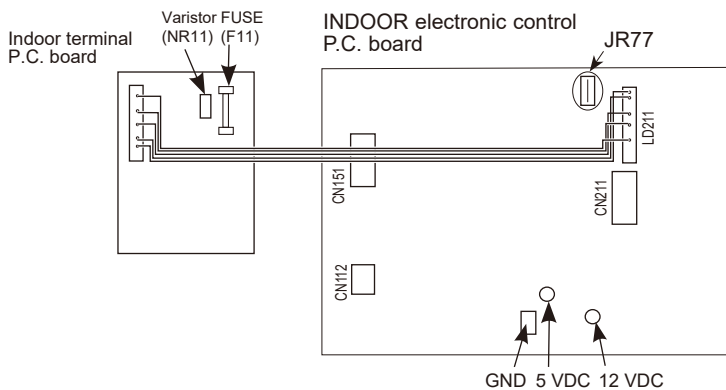

D How to check miswiring and serial signal error

MUZ Type

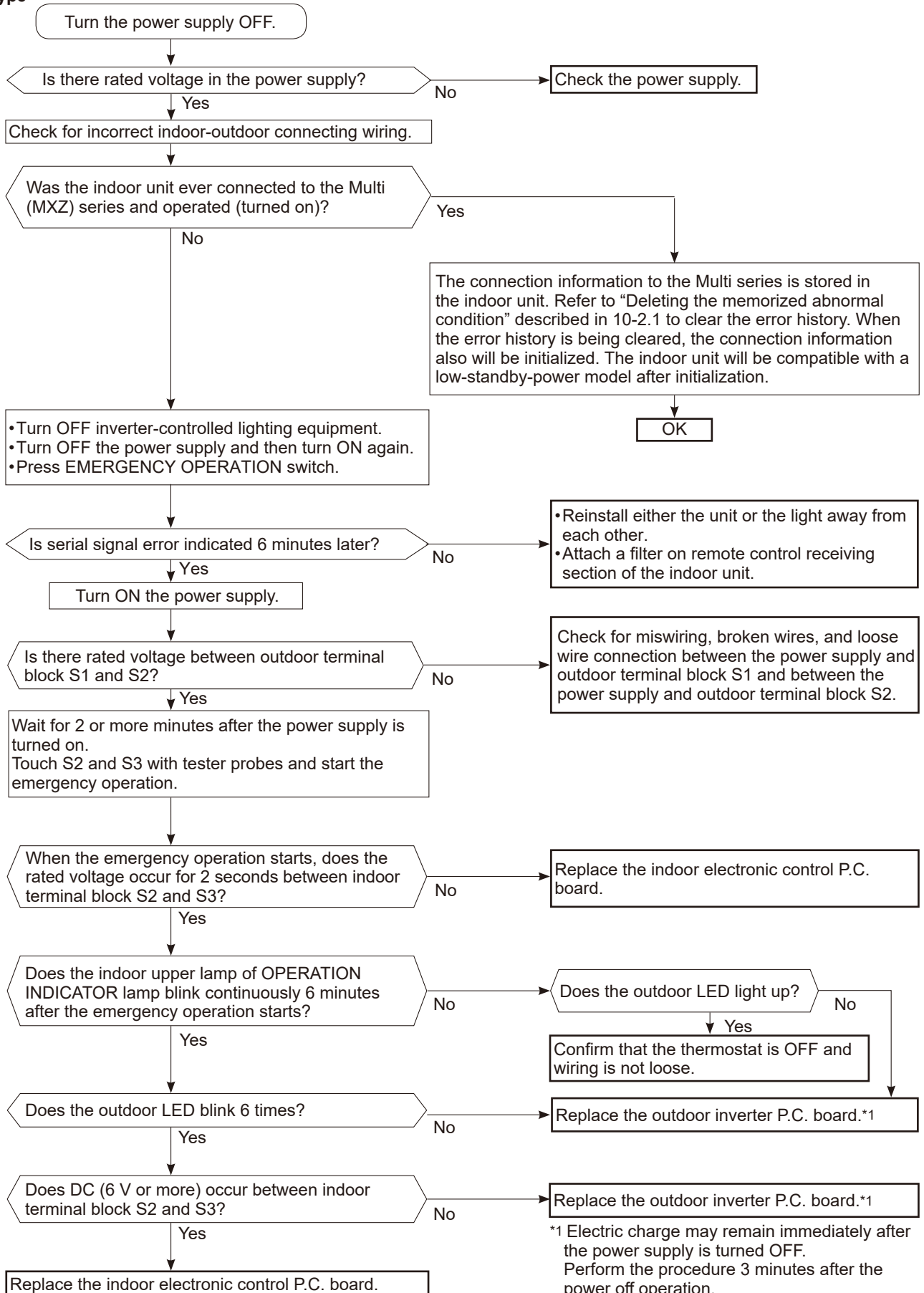

*1 Electric charge may remain immediately after the power supply is turned OFF. Perform the procedure 3 minutes after the power off operation.

MXZ Type

LED indication for communication status

Communication status is indicated by the LED.

Unit status

Blinking: normal communication

Lighting: abnormal communication or not connected

Pattern 1 and 2 is repeatedly displayed alternately. Each pattern is displayed for 10 seconds.

NOTE: "Lighting" in the table below does not indicate abnormal communication.

Outdoor control P.C. board

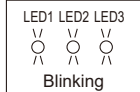

Pattern	LED 1	LED 2	LED 3
1	Unit A status	Unit B status	Lit
2	Unit C status	Unit D status	Not lit
3	Unit E status	—	Blinking

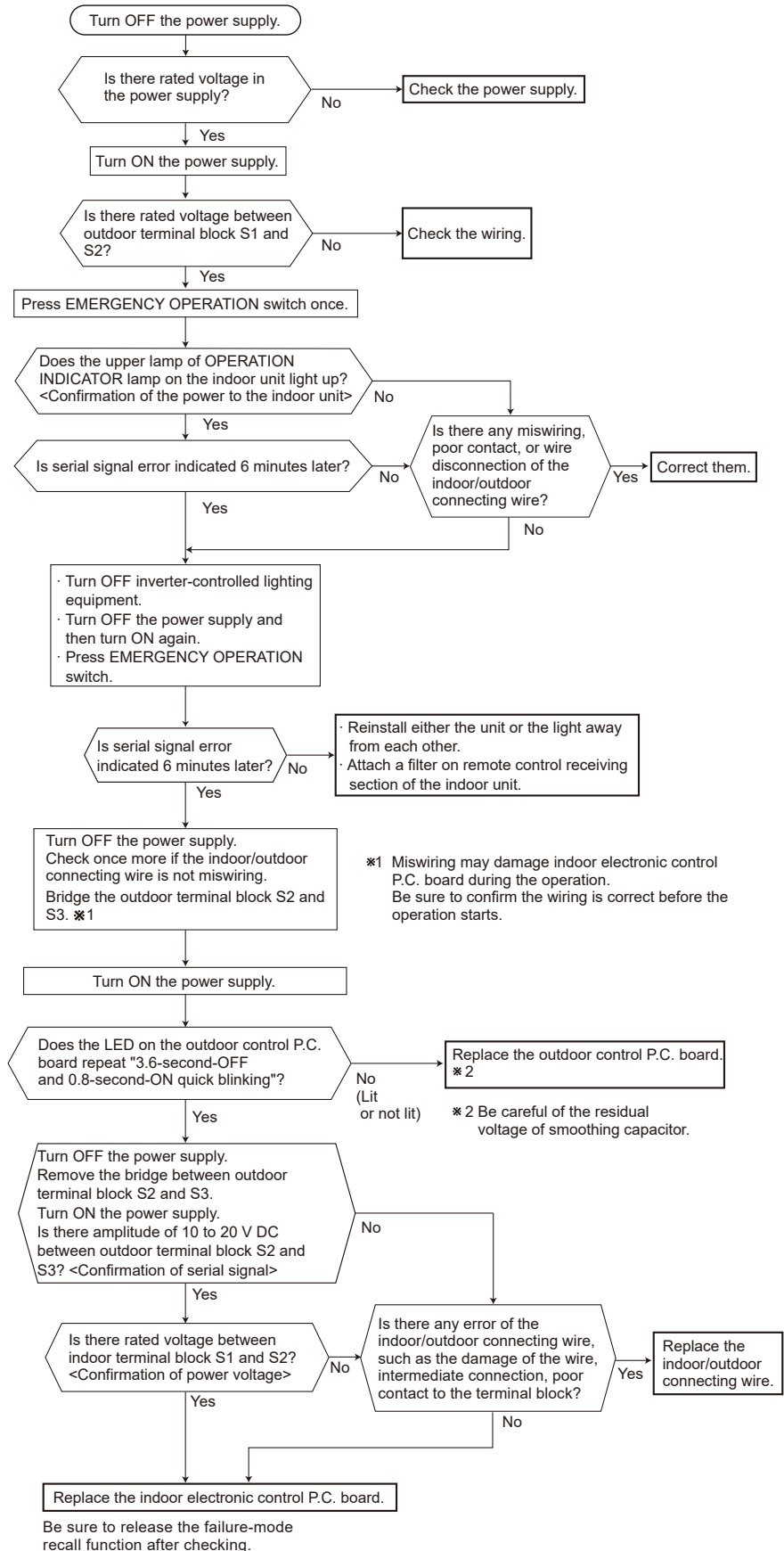

E Electromagnetic noise enters into TV sets or radios

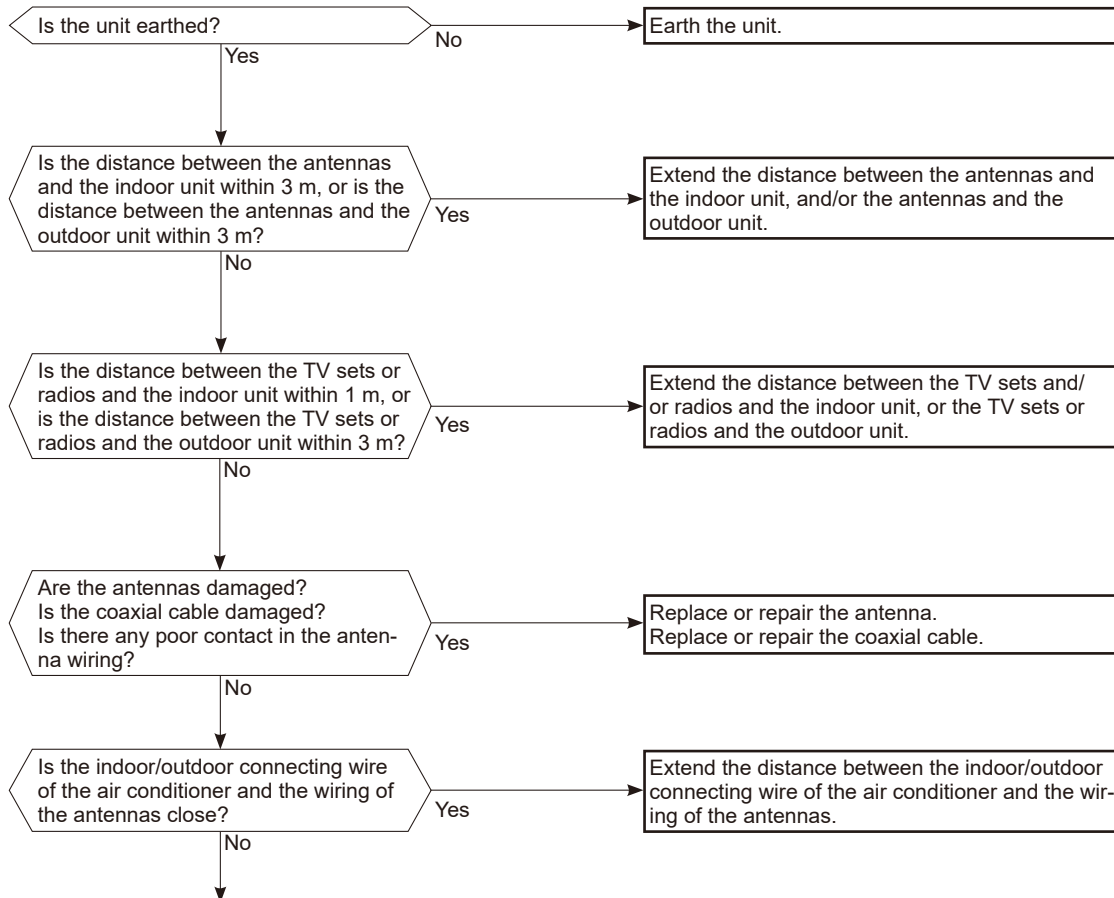

Even if all of the above conditions are fulfilled, the electromagnetic noise may enter, depending on the electric field strength or the installation condition (combination of specific conditions such as antennas or wiring).

Check the following before asking for service.

1. Devices affected by the electromagnetic noise
TV sets, radios (FM/AM broadcast, shortwave)
2. Channel, frequency, broadcast station affected by the electromagnetic noise
3. Channel, frequency, broadcast station unaffected by the electromagnetic noise
4. Layout of:
indoor/outdoor unit of the air conditioner, indoor/outdoor wiring, earth wire, antennas, wiring from antennas, receiver
5. Electric field intensity of the broadcast station affected by the electromagnetic noise
6. Presence or absence of amplifier such as booster
7. Operation condition of air conditioner when the electromagnetic noise enters in
 - 1) Turn OFF the power supply once, and then turn ON the power supply. In this situation, check for the electromagnetic noise.
 - 2) Within 3 minutes after turning ON the power supply, press OFF/ON (stop/operate) button on the remote controller for power ON, and check for the electromagnetic noise.
 - 3) After a short time (3 minutes later after turning ON), the outdoor unit starts running. During operation, check for the electromagnetic noise.
 - 4) Press OFF/ON (stop/operate) button on the remote controller for power OFF, when the outdoor unit stops but the indoor/outdoor communication still runs on. In this situation, check for the electromagnetic noise.

10-7. TEST POINT DIAGRAM AND VOLTAGE

1. Indoor electronic control P.C. board, indoor terminal P.C. board, receiver P.C. board, switch/buzzer P.C. board and display P.C. board

**MSZ-FT25VG MSZ-FT35VG MSZ-FT50VG
MSZ-FT25VGK MSZ-FT35VGK MSZ-FT50VGK**

Indoor electronic control P.C. board

To disable "Auto restart function", cut the Jumper wire to JR77. (Refer to 8-3.)

Cut the jumper wire JR24 when the room temperature does not reach the set temperature during heating operation. (Refer to 8-5.)

Connector to Indoor fan motor (CN211) Resistor (R111)

Indoor terminal P.C. board

Varistor (NR11) Fuse (F11) T3.15AL250V

Connector to Wi-Fi interface (CN110) Connector to vane motor (CN151)

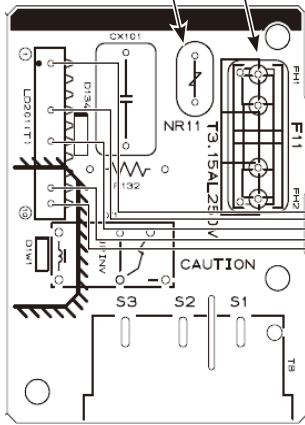

Connector to Indoor coil thermistor RT12, RT13 (CN112) Room temperature thermistor RT11 (CN111)

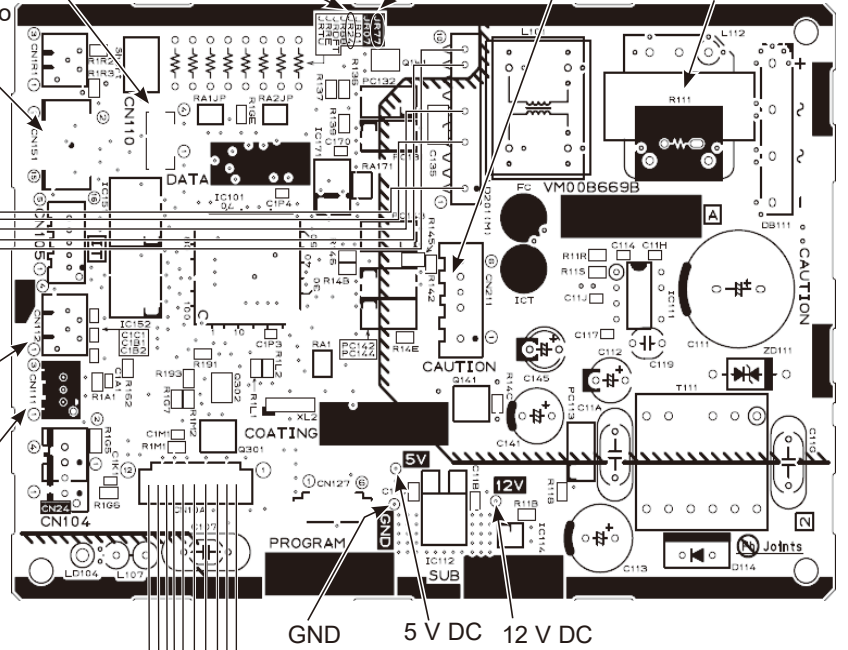

GND 5 V DC 12 V DC

Receiver P.C. board

Display P.C. board

Switch/buzzer P.C. board

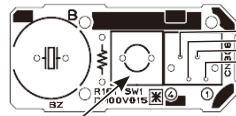

Emergency operation switch (E.O. SW) (SW1)

Room temperature thermistor (RT11) Indoor coil thermistor (RT12, RT13)

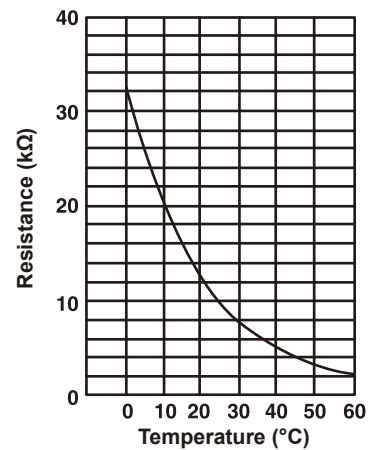

<Detaching method of the terminal with locking mechanism>

The terminal which has the locking mechanism can be detached as shown below.

There are following 2 types of the terminal with locking mechanism.

The terminal without locking mechanism can be detached by pulling it out.

Check the shape of the terminal before detaching.

(1) Slide the sleeve and check if there is a locking lever or not.

(2) The terminal with this connector shown below has the locking mechanism.

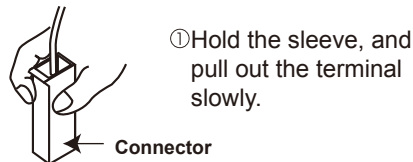
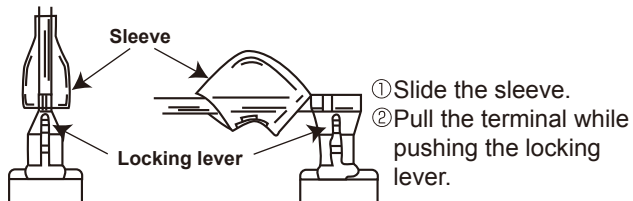
**11-1. MSZ-FT25VG MSZ-FT35VG MSZ-FT50VG**

NOTE: Turn OFF the power supply before disassembly.

—> : Indicates the visible parts in the photos/figures.

---> : Indicates the invisible parts in the photos/figures.

OPERATING PROCEDURE**1. Removing the panel**

- (1) Remove the front panel. Remove the horizontal vanes.
- (2) Remove the screw caps of the panel. Remove the screws of the panel.
- (3) Remove the screw of the Wi-Fi cover on the upper right of the panel, and remove the Wi-Fi cover.
- (4) Unhook the lower part (A) of the panel.
- (5) First, hold the lower part of the right end of the panel, and hold the lower part of the left end of the panel.
- (6) Pull the panel slightly toward you, and then remove the panel by pushing it upward.

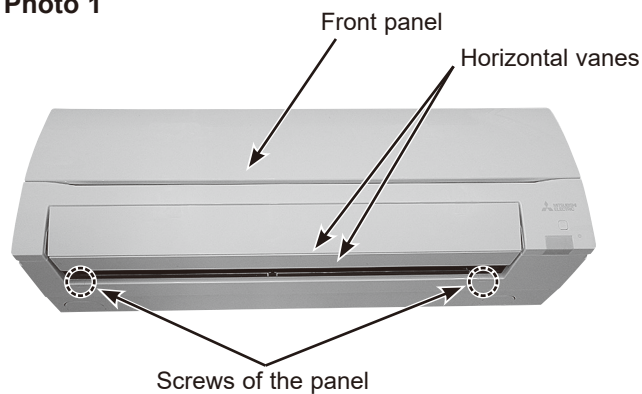
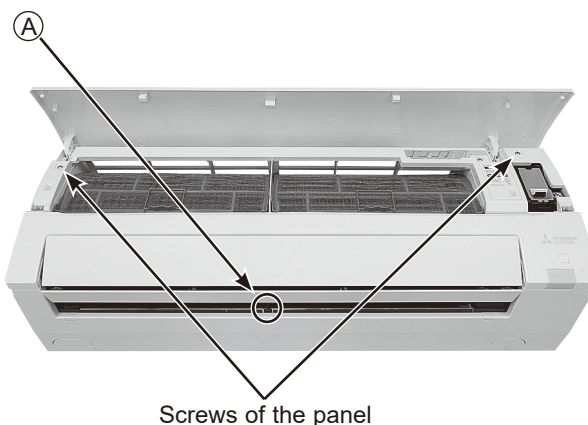
PHOTOS/FIGURES**Photo 1****Photo 2**

OPERATING PROCEDURE

2. Removing the indoor terminal P.C. board, indoor electronic control P.C. board, the display P.C. board, the switch/buzzer P.C. board, the receiver P.C. board, and the electrical box

<Removing the electrical box>

- (1) Remove the panel (Refer to section 1.) and the corner box right .
- (2) Remove the screw of the V.A. clamp. Remove the V.A. clamp and the indoor/outdoor connecting wire.
- (3) Remove the screws of the electrical cover and earth-plate.
- (4) Remove the connectors of the indoor coil thermistors CN112 from the indoor electronic control P.C. board. Remove the wires of the indoor coil thermistor from the water cover.
- (5) Remove the water cover.
- (6) Remove the following connectors from the indoor electronic control P.C. board:
CN151 (Vane motors)
CN211 (Fan motor)
- (7) Remove the upper catch of the electrical box, and pull out the electrical box.

※ To attach the electrical box, pass the wires connecting the display P.C. board, the switch/buzzer P.C. board, the receiver P.C. board, and the indoor electronic control P.C. board through A. Pass the lead wires of the fan motor through B as shown in the Photo 4.

<Removing the indoor terminal P.C. board, indoor electronic control P.C. board, the display P.C. board, the switch/buzzer P.C. board, and the receiver P.C. board>

- (8) Remove the screw of the terminal block and remove the earth wire connected to the electrical box from the indoor electronic control P.C. board.
- (9) Remove the lead wires from the connector CN10A.
- (10) Remove the display P.C. board holder from the electrical box.
- (11) Remove the display P.C. board, the switch/buzzer P.C. board, the receiver P.C. board and the transmitter P.C. board.
- (12) Remove the room temperature thermistor from the electrical box.
Remove the indoor terminal P.C. board and the indoor electronic control P.C. board from the electrical box.
- (13) Unhook the catches of the display P.C. board holder from the nozzle and the electrical box (right side).
- (14) Open the rear cover of the display P.C. board holder and remove the switch board, the display board and the receiver board.
Remove the indoor electronic control P.C. board.

PHOTOS/FIGURES

Photo 3

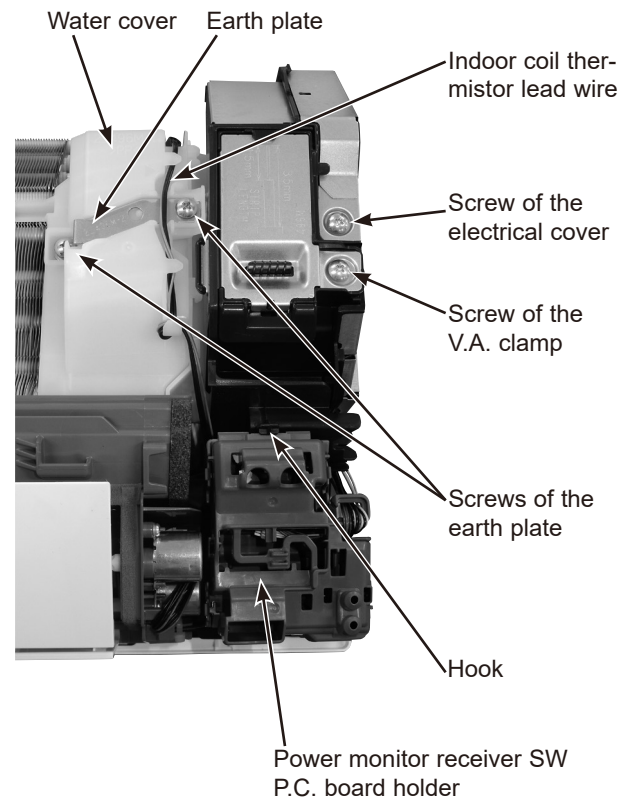
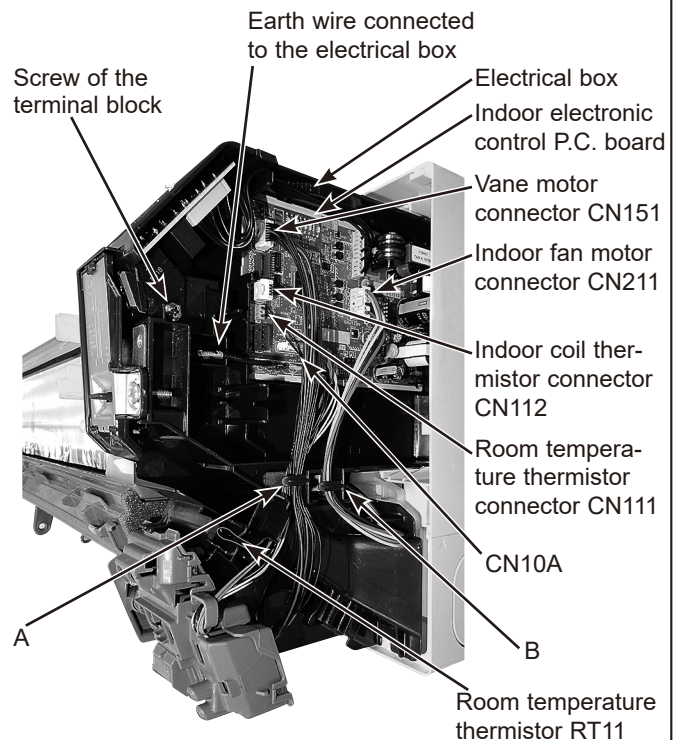

Photo 4



OPERATING PROCEDURE

PHOTOS/FIGURES

3. Removing the nozzle assembly and the vane motor

<Removing the nozzle assembly>

- (1) Remove the panel (Refer to section 1.) and the corner box.
- (2) Remove the V.A. clamp, and then the indoor/outdoor connecting wire. (Refer to section 2.)
- (3) Remove the electrical cover. (Refer to section 2.)
- (4) Disconnect the following connectors on the electronic control P.C. board:
CN151 (Vane motors)
- (5) Pull out the drain hose from the nozzle assembly and remove the nozzle assembly.

Photo 5

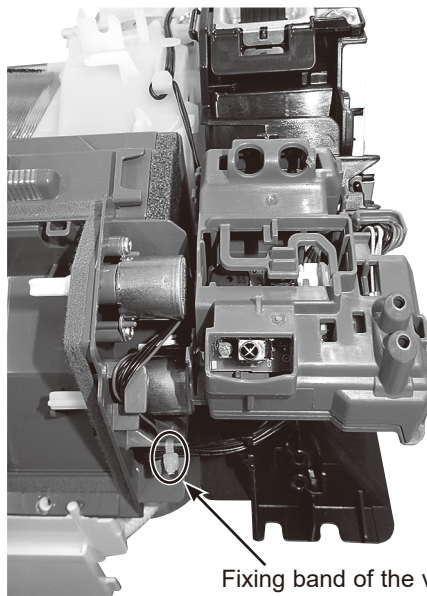

4. Removing the vertical vane motor unit

- (1) Remove the nozzle assembly. (Refer to section 3.)
- (2) Remove the crank of the vertical vane motor from the arm of the vertical vane.
- (3) Remove the screw of the vertical vane motor, and pull the vertical vane motor.
- (4) Remove the crank of the vertical vane motor unit from the shaft of the vane motor.
- (5) Remove the vertical vane motor from the vertical vane motor unit.
- (6) Disconnect the connector of vertical vane motor from the vertical vane motor.

Photo 6

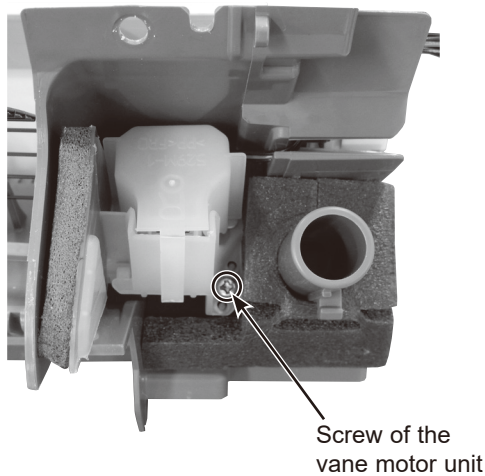

5. Removing the horizontal vane motor

- (1) Cut the fixing band of the vane motor lead wire. (Photo 5)
- (2) Remove the screws of the horizontal vane motors and remove the horizontal vane motors. (Photo 7)
- (3) Disconnect the connectors from the horizontal vane motors.

Photo 7

Screws of the horizontal vane motor

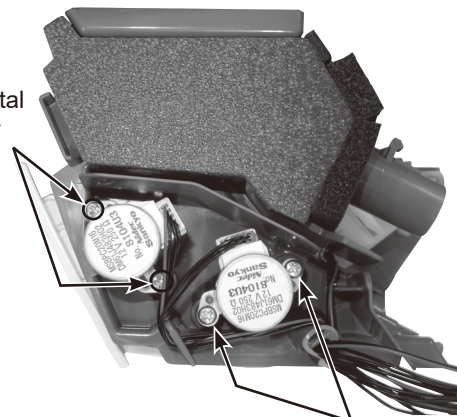

Screws of the horizontal vane motor

OPERATING PROCEDURE

6. Removing the indoor fan motor, the indoor coil thermistor and the line flow fan

- (1) Remove the panel. (Refer to section 1.)
Remove the right corner box.
- (2) Remove the electrical box and the nozzle assembly. (Refer to section 2, 3.)
- (3) Remove the screws fixing the motor bed.
- (4) Loosen the screw fixing the line flow fan.
- (5) Remove the motor bed together with the indoor fan motor and the motor band.
- (6) Disconnect the lead wire of the fan motor from the motor band.
- (7) Disengage the hooks of the motor band and remove the motor band. Pull out the indoor fan motor.
- (8) Remove the indoor coil thermistor from the indoor heat exchanger.
* Install the indoor coil thermistor in its former position when assembling it.
- (9) Remove the screws fixing the left side of the indoor heat exchanger.
- (10) Lift the indoor heat exchanger, and pull out the line flow fan to the lower-left.
* When attaching the line flow fan, screw the line flow fan so 4 mm gap is provided between the right end of the line flow fan and the right wall of the air passage of the box (Figure 1).

Figure 1

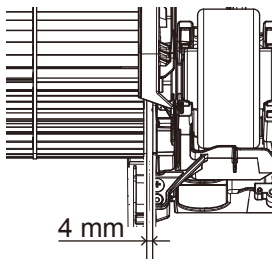
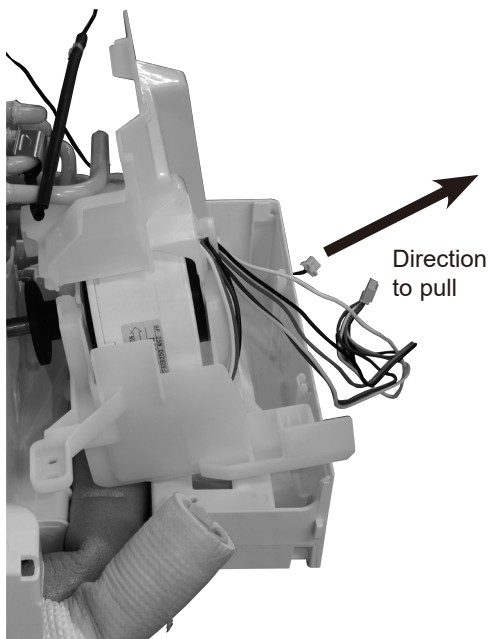

Photo 10



PHOTOS/FIGURES

Photo 8

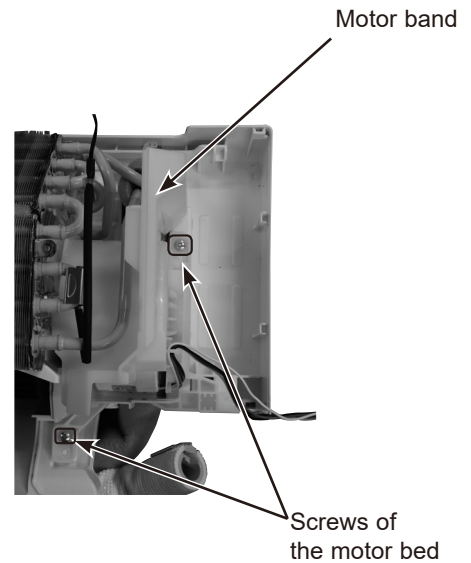

Photo 9

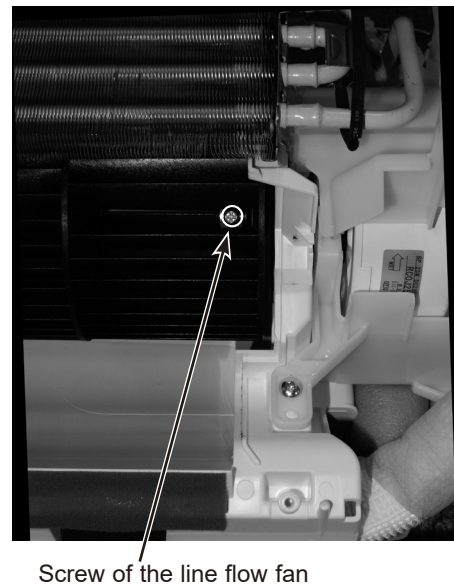
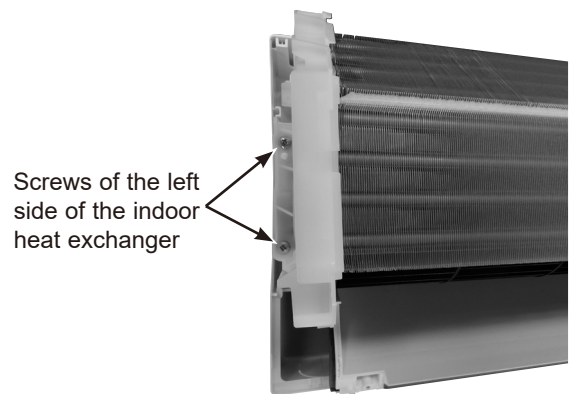

Photo 11



11-2. MSZ-FT25VGK MSZ-FT35VGK MSZ-FT50VGK

NOTE: Turn OFF the power supply before disassembly.

→ : Indicates the visible parts in the photos/figures.
 ---→ : Indicates the invisible parts in the photos/figures.

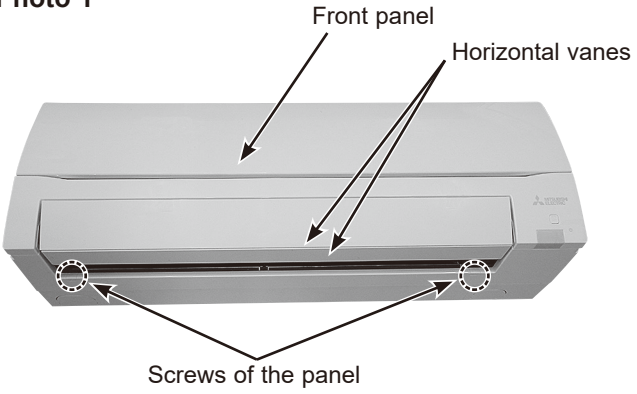
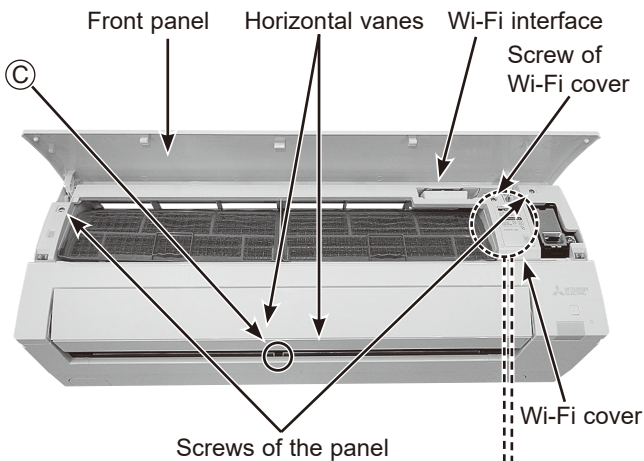
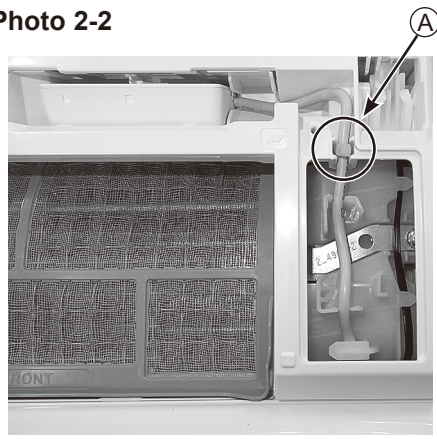
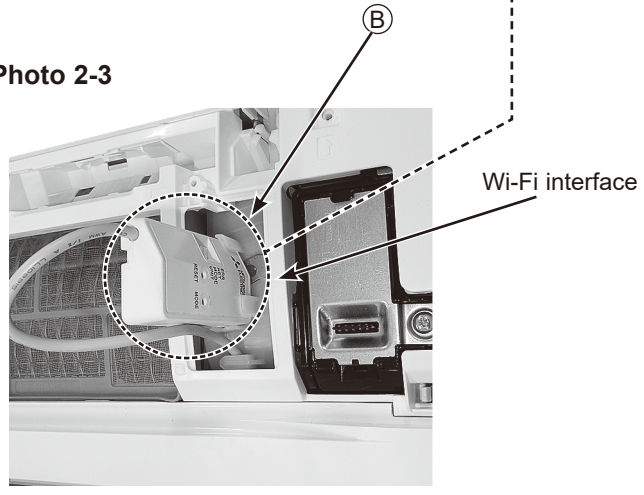
OPERATING PROCEDURE	PHOTOS/FIGURES
<p>1. Removing the panel</p> <ol style="list-style-type: none"> (1) Remove the front panel. Remove the horizontal vanes. (2) Remove the screw caps of the panel. Remove the screws of the panel. (3) Remove the screw of the Wi-Fi cover on the upper right of the panel, and remove the Wi-Fi cover. (4) Remove the Wi-Fi interface on the right side of the panel. Pull out the Wi-Fi cable, and pull out the cable tie fixed on the panel. (A) (5) Insert Wi-Fi interface into the water cut (B) in the same direction as Photo 1-3, and fix it temporary. (6) Unhook the lower part (C) of the panel. (7) First, hold the lower part of the right end of the panel, and hold the lower part of the left end of the panel. (8) Pull the panel slightly toward you, and then remove the panel by pushing it upward. <p>Photo 1</p>  <p>Photo 2-1</p>  <p>Photo 2-2</p>  <p>Photo 2-3</p> 	

OPERATING PROCEDURE

2. Removing the Wi-Fi interface

- (1) Remove the panel (Refer to section 1.) and the corner box right.
- (2) Remove the screw of the V.A. clamp. Remove the V.A. clamp and the indoor/outdoor connecting wire.
- (3) Remove the screw of the electrical cover, and remove the electrical cover.
- (4) Disconnect the following connector (Photo 4-1, 2): <Indoor electronic control P.C. board> CN110 (Wi-Fi interface)
- (5) Remove the lead wire of the Wi-Fi interface from the hook of the cable guide and water cut.

3. Removing the indoor electrical box

- (1) Remove the panel (Refer to section 1.) and the corner box right.
- (2) Remove the screw of the V.A. clamp. Remove the V.A. clamp and the indoor/outdoor connecting wire.
- (3) Remove the screw of the earth plate and the earth plate.
- (4) Remove the screw of the electrical cover and remove the electrical cover.
- (5) Disconnect following connectors: <Indoor electronic control P.C. board> CN151 (Vane motor) CN110 (Wi-Fi interface) <Indoor power P.C. board> CN211 (Indoor fan motor)
- (6) Remove the lead wire of the Wi-Fi interface, and remove the Wi-Fi interface (Refer to section 2.).
- (7) Remove the screw fixing the electrical box, then the upper catch of the electrical box, and pull out the electrical box.

4. Removing the indoor terminal P.C. board, indoor electronic control P.C. board, the display P.C. board, the switch/buzzer P.C. board, and the receiver P.C. board

- (1) Remove the panel (Refer to Section 1.) and the corner box right.
- (2) Remove the screw of the V.A. clamp. Remove the V.A. clamp and the indoor/outdoor connecting wire.
- (3) Remove the indoor electrical box (Refer to section 3.).
- (4) Remove the screw of the terminal block and remove the earth wire connected to the electrical box from the indoor electronic control P.C. board.
- (5) Remove the lead wires from the connector CN10A.
- (6) Remove the display P.C. board holder from the electrical box.
- (7) Remove the the display P.C. board, the switch/buzzer P.C. board, and the receiver P.C. board.
- (8) Remove the room temperature thermistor from the electrical box . Remove the indoor terminal P.C. board and the indoor electronic control P.C. board from the electrical box.
- (9) Unhook the catches of the display P.C. board holder from the nozzle and the electrical box (right side).
- (10) Open the rear cover of the display P.C. board holder and remove the switch board, the display board and the receiver board. Remove the indoor electronic control P.C. board.

PHOTOS/FIGURES

Photo 3

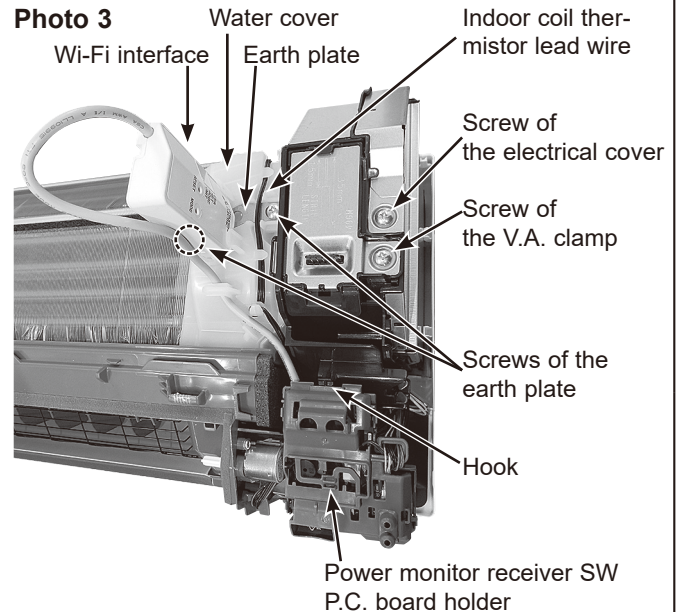

Photo 4-1

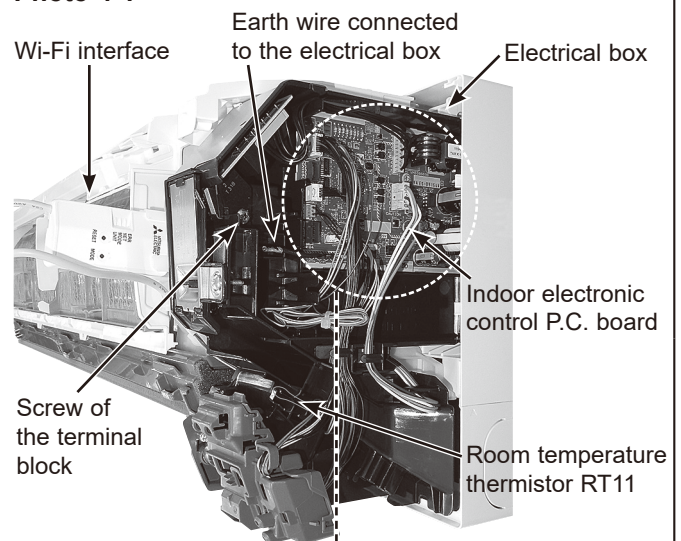
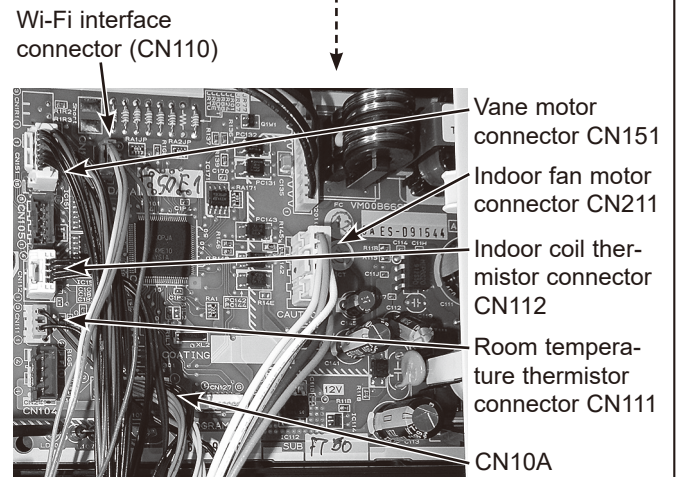

Photo 4-2



OPERATING PROCEDURE

PHOTOS/FIGURES

5. Removing the nozzle assembly and the vane motor

<Removing the nozzle assembly>

- (1) Remove the panel (Refer to section 1.) and the corner box.
- (2) Remove the V.A. clamp, and then the indoor/outdoor connecting wire. (Refer to section 2.)
- (3) Remove the electrical cover. (Refer to section 2.)
- (4) Disconnect the following connectors on the electronic control P.C. board:
CN151 (Vane motors)
- (5) Pull out the drain hose from the nozzle assembly and remove the nozzle assembly.

Photo 5

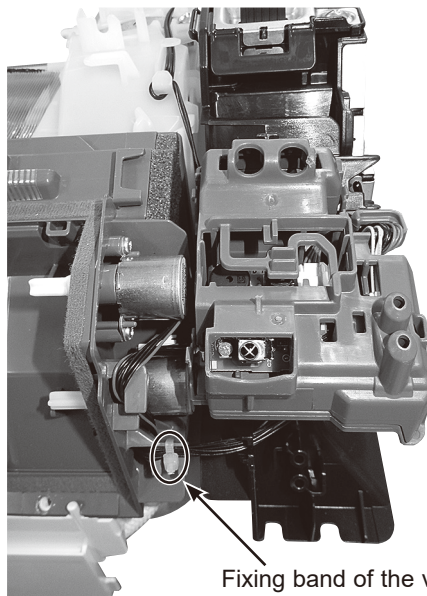

Fixing band of the vane motor lead wire

6. Removing the vertical vane motor unit

- (1) Remove the nozzle assembly. (Refer to section 5.)
- (2) Remove the crank of the vertical vane motor from the arm of the vertical vane.
- (3) Remove the screw of the vertical vane motor, and pull the vertical vane motor.
- (4) Remove the crank of the vertical vane motor unit from the shaft of the vane motor.
- (5) Remove the vertical vane motor from the vertical vane motor unit.
- (6) Disconnect the connector of vertical vane motor from the vertical vane motor.

Photo 6

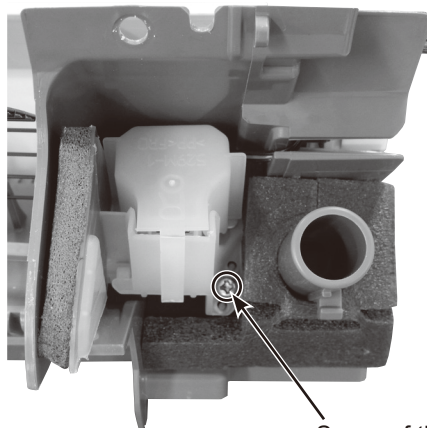

Screw of the vane motor unit

7. Removing the horizontal vane motor

- (1) Cut the fixing band of the vane motor lead wire. (Photo 5)
- (2) Remove the screws of the horizontal vane motors and remove the horizontal vane motors. (Photo 7)
- (3) Disconnect the connectors from the horizontal vane motors.

Photo 7

Screws of the horizontal vane motor



Screws of the horizontal vane motor

OPERATING PROCEDURE

8. Removing the indoor fan motor, the indoor coil thermistor and the line flow fan

- (1) Remove the panel. (Refer to section 1.)
Remove the right corner box.
- (2) Remove the electrical box and the nozzle assembly. (Refer to section 2, 3.)
- (3) Remove the screws fixing the motor bed.
- (4) Loosen the screw fixing the line flow fan.
- (5) Remove the motor bed together with the indoor fan motor and the motor band.
- (6) Disconnect the lead wire of the fan motor from the motor band.
- (7) Disengage the hooks of the motor band and remove the motor band. Pull out the indoor fan motor.
- (8) Remove the indoor coil thermistor from the indoor heat exchanger.
※ Install the indoor coil thermistor in its former position when assembling it.
- (9) Remove the screws fixing the left side of the indoor heat exchanger.
- (10) Lift the indoor heat exchanger, and pull out the line flow fan to the lower-left.
※ When attaching the line flow fan, screw the line flow fan so 4 mm gap is provided between the right end of the line flow fan and the right wall of the air passage of the box (Figure 1).

Figure 1

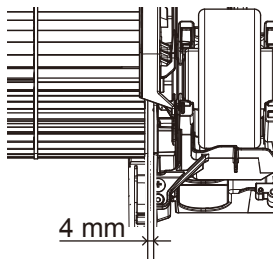
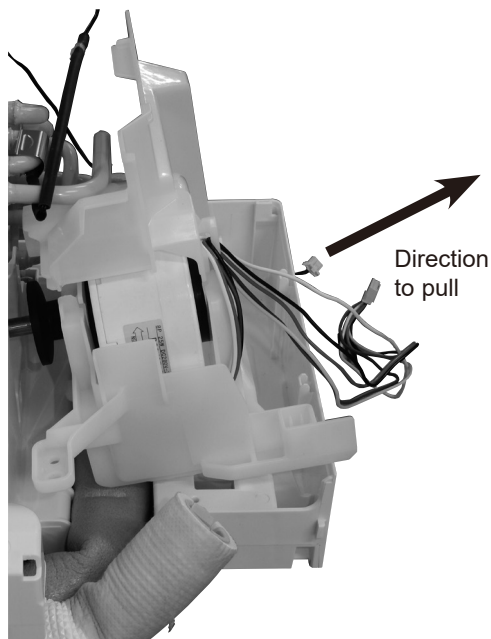

Photo 10



PHOTOS/FIGURES

Photo 8

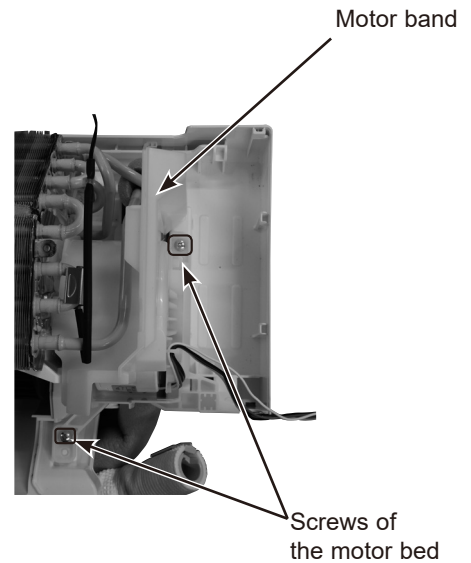

Photo 9

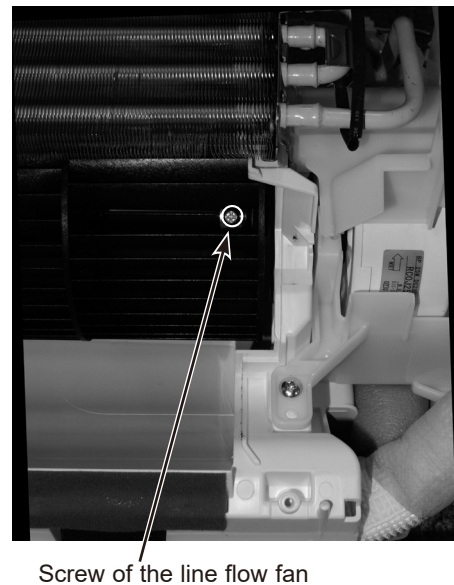
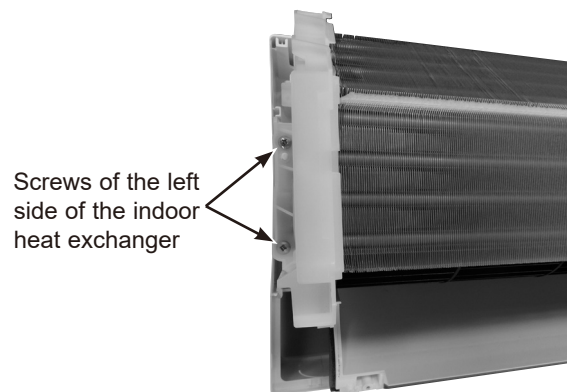

Photo 11



Fixing the indoor coil thermistor

※ There are 2 forms of parts for fixing the indoor coil thermistor.

Clip shape



Holder shape



When fixing the indoor coil thermistor to the clip-shape/holder-shape part, the lead wire should point down.

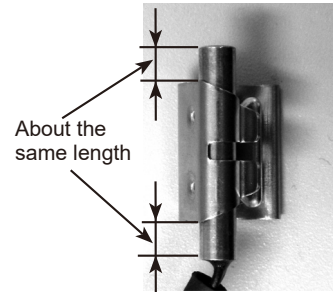

Position and procedure for mounting the clip-shape part

1. Set the indoor coil thermistor in the center of the clip-shape part.

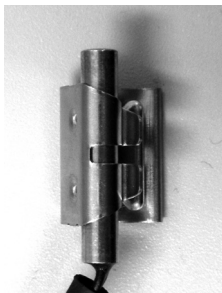

2. Check the (marked) mounting position.



3. Mount the clip-shape part.



NOTE:

- Take care to avoid loss and accidental falling of the clip-shape part inside the unit.
- Mount the clip-shape part on the marked position.
- Do not pull the lead wire when removing the indoor coil thermistor.

mitsubishi ELECTRIC CORPORATION

HEAD OFFICE: TOKYO BUILDING, 2-7-3, MARUNOUCHI, CHIYODA-KU, TOKYO 100-8310, JAPAN